

DISPLAY THIS CARD ON PRINCIPAL FRONTAGE OF WORK
CITY OF PORTLAND

Please Read
Application And
Notes, If Any,
Attached

**BUILDING INSPECTION
PERMIT**

Permit Number: 061388

This is to certify that MORGENSTERN MICHAEL Home owner

has permission to Remove shed, remove window and replace with door and add exterior stairs for door

AT 26 FREDERIC ST

076 A013001

PERMIT ISSUED
NOV - 9 2006
CITY OF PORTLAND

provided that the person or persons who apply for and accept this permit shall comply with all of the provisions of the Statutes of the State and of the Ordinances of the City of Portland regarding the construction, maintenance and use of buildings and structures, and of the application on file in this department.

Apply to Public Works for street line and grade if nature of work requires such information.

Notification of inspection must be given and when permission procured before this building or part thereof is occupied or service closed-in. 4
YOUR NOTIFICATION IS REQUIRED.

A certificate of occupancy must be procured by owner before this building or part thereof is occupied.

OTHER REQUIRED APPROVALS

Fire Dept. Jay Kelley P.F.D. 10/3/06

Health Dept. _____

Appeal Board _____

Other _____
Department Name

Jeanie Benke 11/9/06
Director - Building & Inspection Services

PENALTY FOR REMOVING THIS CARD

City of Portland, Maine - Building or Use Permit Application
 389 Congress Street, 04101 Tel: (207) 874-8703, Fax: (207) 874-8716

Permit No: 06-1388	Issue Date:	CBL: 076 A013001
-----------------------	-------------	---------------------

Location of Construction: 26 FREDERIC ST	Owner Name: MORGENSTERN MICHAEL	Owner Address: 26 FREDERIC ST	Phone:
Business Name:	Contractor Name: Home owner	Contractor Address:	Phone:
Lessee/Buyer's Name	Phone:	Permit Type: Alterations - Commercial	Zone: R6

Past Use: Three family <i>legal use -</i>	Proposed Use: Three Family - remove shed, remove window and replace with french door and add exterior stairs for door <i>3 du (#02-0154)</i>	Permit Fee: \$40.00	Cost of Work: \$1,500.00	CEO District: 3
Proposed Project Description: Remove shed, remove window and replace with french door and add exterior stairs for door <i>After The Fact</i>		FIRE DEPT: <input checked="" type="checkbox"/> Approved <input type="checkbox"/> Denied <i>JLK P.F.D. 10/3/06</i>	INSPECTION: Use Group: <i>R2</i> Type: <i>SB</i> <i>IBC-2003</i> Signature: <i>JMB 11/9/06</i>	
PEDESTRIAN ACTIVITIES DISTRICT (P.A.D.) Action: <input type="checkbox"/> Approved <input type="checkbox"/> Approved w/Conditions <input type="checkbox"/> Denied Signature: _____ Date: _____				

Permit Taken By: dmartin	Date Applied For: 09/20/2006	Zoning Approval
-----------------------------	---------------------------------	------------------------

- This permit application does not preclude the Applicant(s) from meeting applicable State and Federal Rules.
- Building permits do not include plumbing, septic or electrical work.
- Building permits are void if work is not started within six (6) months of the date of issuance. False information may invalidate a building permit and stop all work..

Special Zone or Reviews <input type="checkbox"/> Shoreland <input type="checkbox"/> Wetland <input type="checkbox"/> Flood Zone <input type="checkbox"/> Subdivision <input type="checkbox"/> Site Plan Maj <input type="checkbox"/> Minor <input type="checkbox"/> MM <input type="checkbox"/> <i>OK w/conditions</i> Date: <i>9/28/06</i> <i>ABM</i>	Zoning Appeal <input type="checkbox"/> Variance <input type="checkbox"/> Miscellaneous <input type="checkbox"/> Conditional Use <input type="checkbox"/> Interpretation <input type="checkbox"/> Approved <input type="checkbox"/> Denied Date: _____	Historic Preservation <input checked="" type="checkbox"/> Not in District or Landmark <input type="checkbox"/> Does Not Require Review <input type="checkbox"/> Requires Review <input type="checkbox"/> Approved <input type="checkbox"/> Approved w/Conditions <input type="checkbox"/> Denied <i>ABM</i> Date: _____
---	---	--

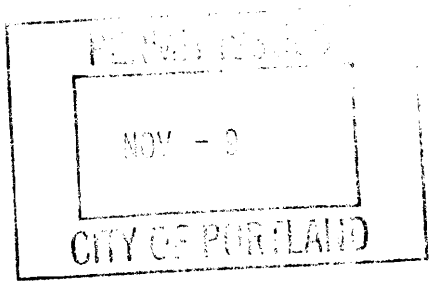

CERTIFICATION

I hereby certify that I am the owner of record of the named property, or that the proposed work is authorized by the owner of record and that I have been authorized by the owner to make this application as his authorized agent and I agree to conform to all applicable laws of this jurisdiction. In addition, if a permit for work described in the application is issued, I certify that the code official's authorized representative shall have the authority to enter all areas covered by such permit at any reasonable hour to enforce the provision of the code(s) applicable to such permit.

SIGNATURE OF APPLICANT	ADDRESS	DATE	PHONE
RESPONSIBLE PERSON IN CHARGE OF WORK, TITLE		DATE	PHONE

City of Portland, Maine - Building or Use Permit

389 Congress Street, 04101 Tel: (207) 874-8703, Fax: (207) 874-8716

Permit No: 06-1388	Date Applied For: 09/20/2006	CBL: 076 A013001
------------------------------	--	----------------------------

Location of Construction: 26 FREDERIC ST	Owner Name: MORGENSTERN MICHAEL	Owner Address: 26 FREDERIC ST	Phone:
Business Name:	Contractor Name: Home owner	Contractor Address:	Phone:
Lessee/Buyer's Name	Phone:	Permit Type: Alterations - Multi Family	

Proposed Use: After the fact, three Family - remove shed, remove window and replace with french door and add exterior stairs for door	Proposed Project Description: After the fact, remove shed, remove window and replace with french door and add exterior stairs for door
---	--

Dept: Zoning **Status:** Approved with Conditions **Reviewer:** Ann Machado **Approval Date:** 09/28/2006

Note: **Ok to Issue:**

- 1) This property shall remain as a three family dwelling. Any change of use shall require a separate permit application for review and approval.
- 2) This permit is being approved on the basis of plans submitted. Any deviations shall require a separate approval before starting that work.

Dept: Building **Status:** Approved with Conditions **Reviewer:** Jeanine Bourke **Approval Date:** 11/09/2006

Note: **Ok to Issue:**

- 1) Permit approved based on the plans submitted and reviewed w/owner/contractor, with additional information as agreed on and as noted on plans.

Dept: Fire **Status:** Approved **Reviewer:** Jay Kelley **Approval Date:** 10/03/2006

Note: **Ok to Issue:**

- 1) Build to applicable codes

Comments:

9/28/2006-amachado: I have a call into Michael Morganstein, the owner. Questions about shed (garage?) that is being removed. Do they want to repalce it?

9/28/2006-amachado: Deanna Drzechowski left a voicemail. Said the building is a shed and she knows that she will be losing the right to rebuild it in the existing footprint. She said that she wanted to extend the driveway and that is why they want to remove it.

10/20/2006-jmb: Left vm w/Deanna for details on which wall had the new door and if it was a bearing wall

10/23/2006-jmb: Deanna called, didn't have info on header size, will have her father call

11/9/2006-jmb: Bob the contractor called an verified that the wall was nonbearing and the 2 x 4 header is ok for 8' if this is the case. Ok to issue

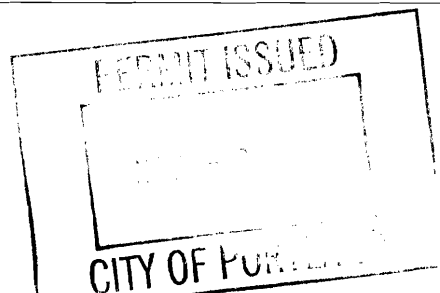



General Building Permit Application

If you or the property owner owes real estate or personal property taxes or user charges on any property within the City, payment arrangements must be made before permits of any kind are accepted.

Location/Address of Construction: <u>26 Frederic St.</u>		
Total Square Footage of Proposed Structure		Square Footage of Lot
Tax Assessor's Chart, Block & Lot Chart# Block# Lot# <u>76 A 013</u>	Owner: <u>Michael Morgenstein</u>	Telephone: <u>899-0162</u>
Lessee/Buyer's Name (If Applicable)	Applicant name, address & telephone: <u>Michael Morgenstein 26 Frederic St., Apt. 1R Portland, ME 04102 899-0162</u>	Cost Of Work: \$ <u>1500.00</u> Fee: \$ <u>40.</u> C of O Fee: \$ _____
Current Specific use: <u>put in french door in place of window & tear down shed</u> If vacant, what was the previous use? _____ Proposed Specific use: _____		
Project description: <u>take out current window & replace w/ french door & concrete stairs to back yard. Take down shed.</u> <u>After the Fact</u>		
Contractor's name, address & telephone: <u>N/A</u>		
Who should we contact when the permit is ready: <u>Deanna Orzechowski</u>		
Mailing address: <u>26 Frederic St. Apt. 1R Portland, ME 04102</u> Phone: <u>899-0162</u>		

Please submit all of the information outlined in the Commercial Application Checklist. Failure to do so will result in the automatic denial of your permit.

In order to be sure the City fully understands the full scope of the project, the Planning and Development Department may request additional information prior to the issuance of a permit. For further information visit us on-line at www.portlandmaine.gov, stop by the Building Inspections office, room 315 City Hall or call 874-8703.

I hereby certify that I am the Owner of record of the named property, or that the owner of record authorizes the proposed work and that I have been authorized by the owner to make this application as his/her authorized agent. I agree to conform to all applicable laws of this jurisdiction. In addition, if a permit for work described in this application is issued, I certify that the Code Official's authorized representative shall have the authority to enter all areas covered by this permit at any reasonable hour to enforce the provisions of the codes applicable to this permit.

Signature of applicant: <u>[Signature]</u>	Date: <u>09/13/06</u>
--	-----------------------

DEPT. OF BUILDING INSPECTION
CITY OF PORTLAND, ME

SEP 21 2006

RECEIVED

This is not a permit; you may not commence ANY work until the permit is issued.

CC

R6 - Feb lot size 5,000 sq ft

front porch - ck

rear porch - ck

side porch - ck

lot coverage - 2700 sq ft

50'

1 story with
1 car garage

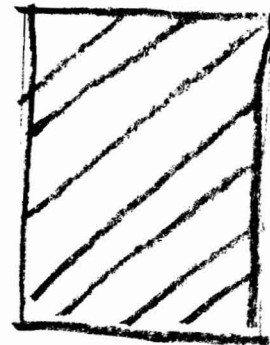

50'

2 story house
house w/ ck L
concrete block
foundation

100' ±

100' ±

Stairs

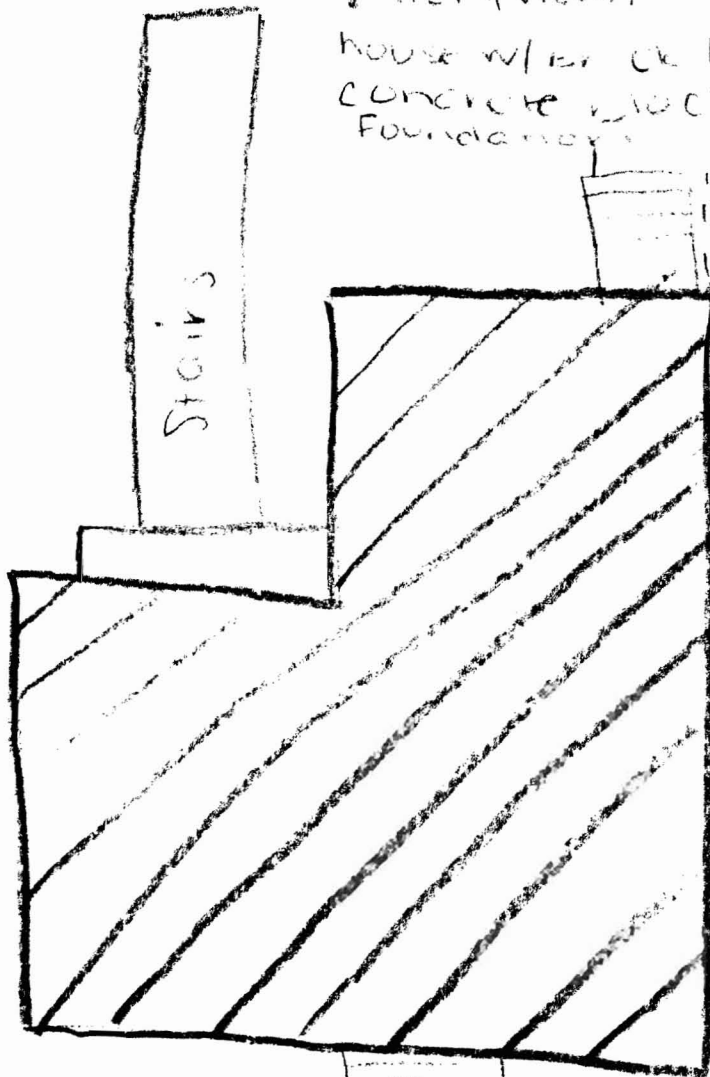

100' ±
100' ±

APPROXIMATE

50' ±

100'

Brick

Window
is
broken
and
was
replaced w/ door

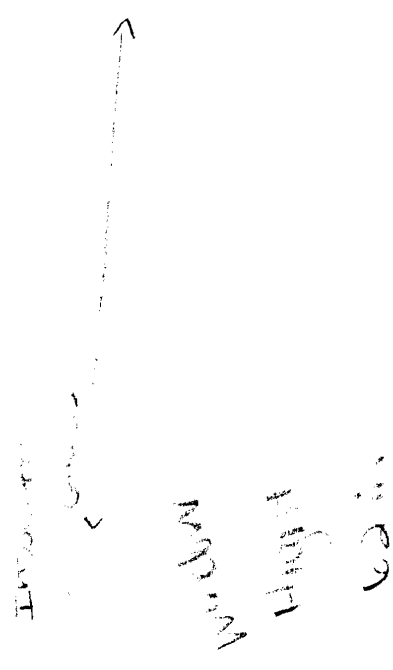
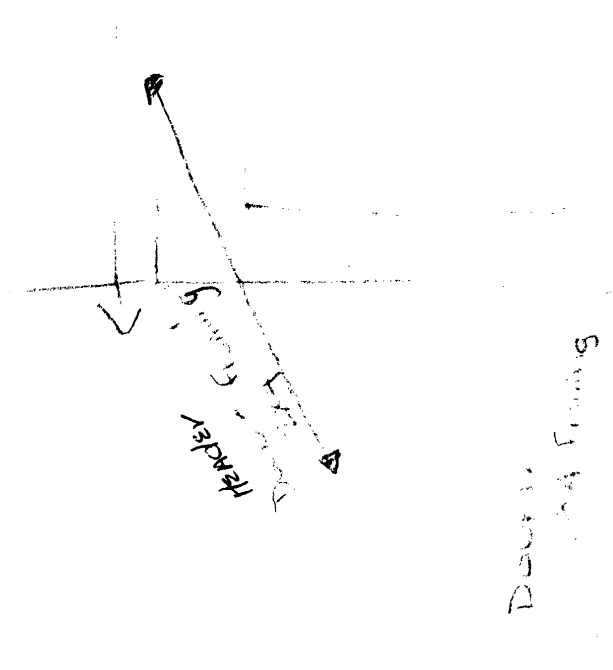
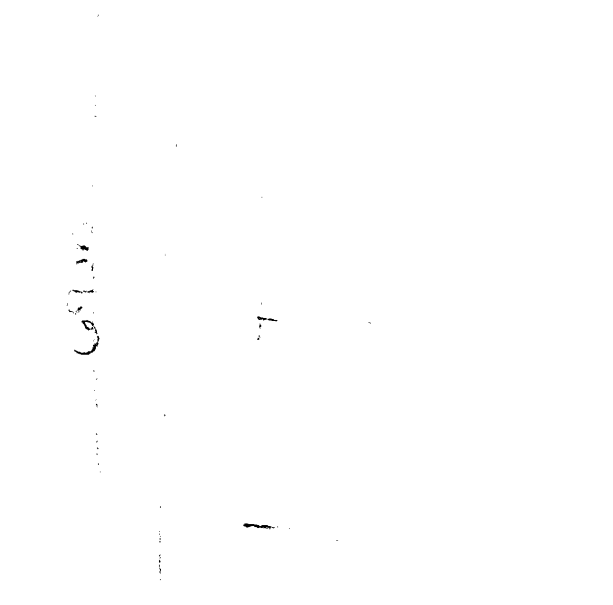
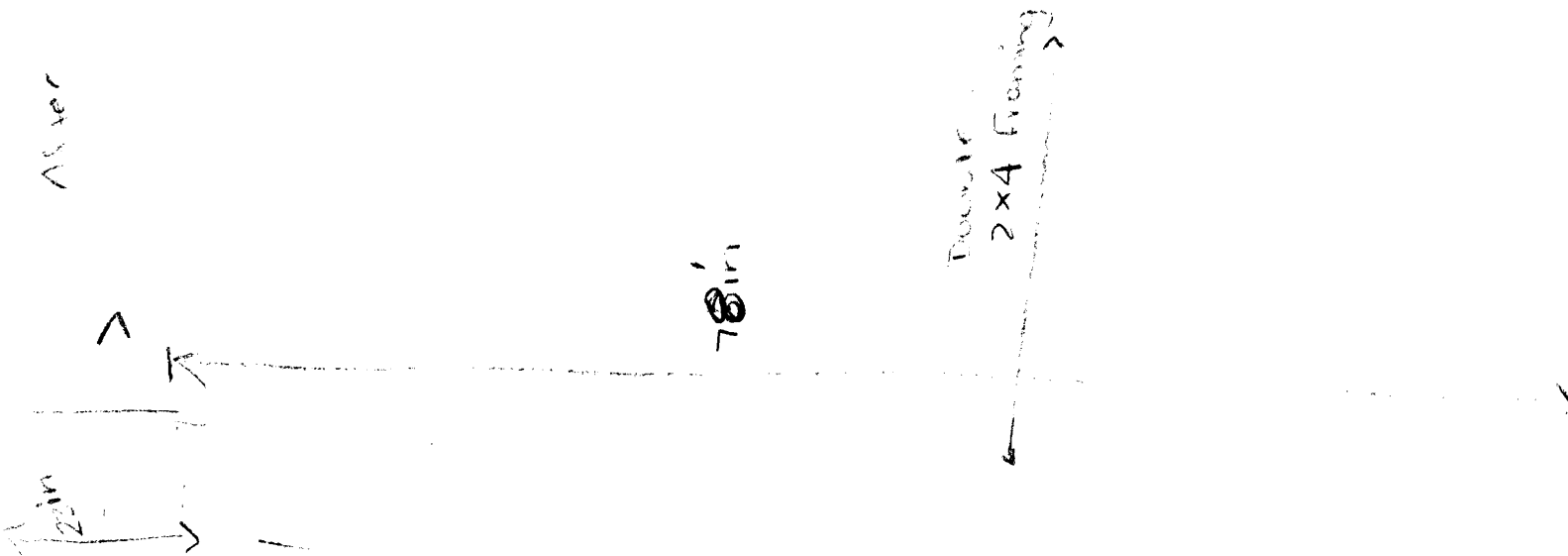

Swan's Concrete Products
674 Bridgton Road
Westbrook, Maine 04092 854-5324

STEPS

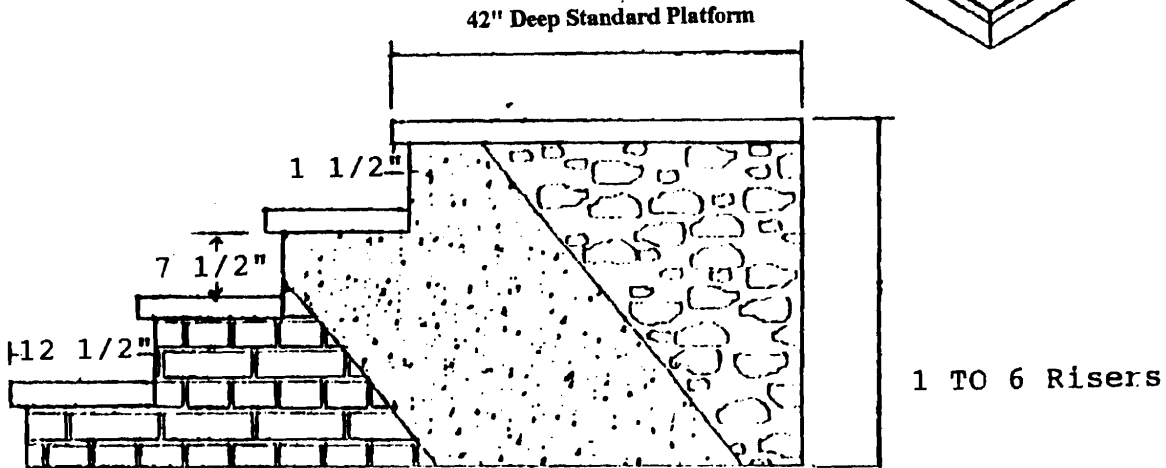
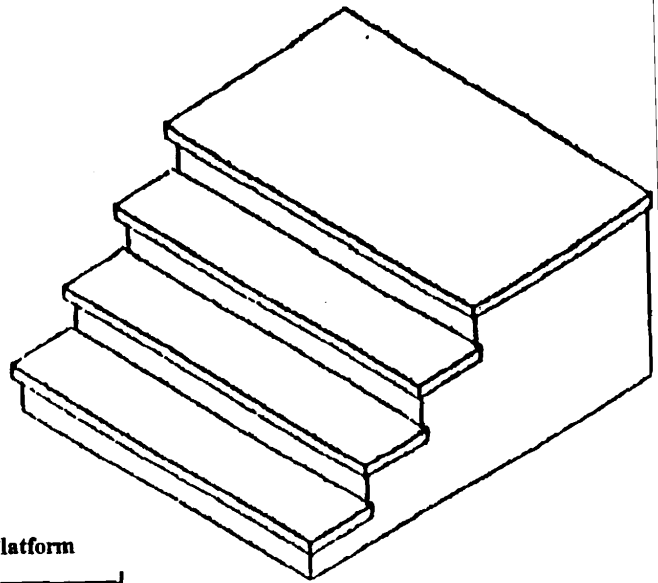

Available in Brick, Stone, Exposed, or Plain Finish

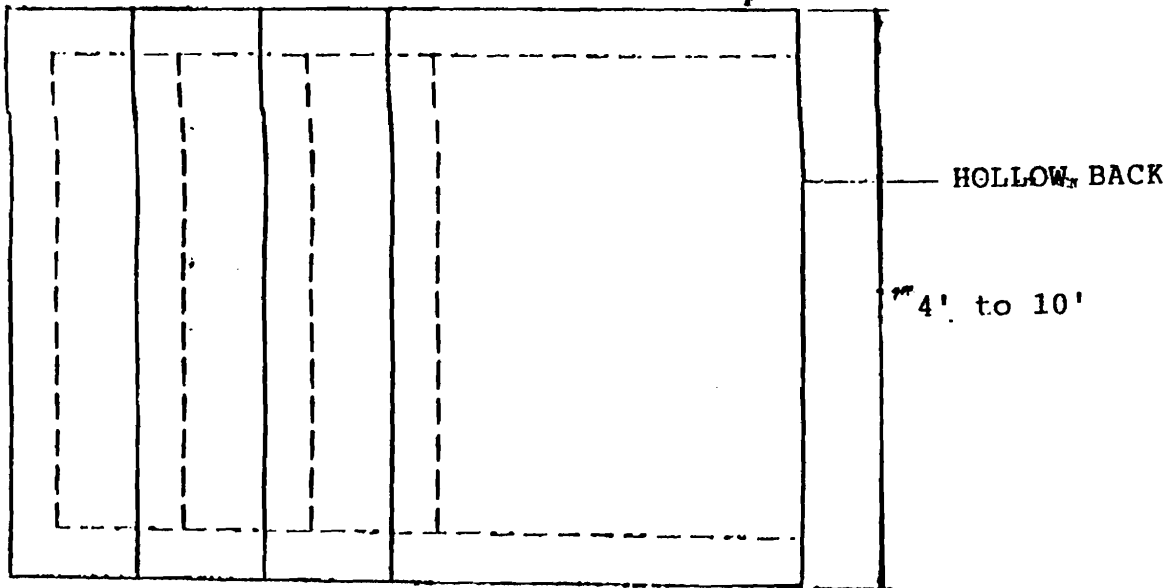

Notes

1. Concrete is 5,000 PSI in 28 Days
2. Steel Reinforced
3. Waterproof Coating Available
4. Salt or Chemical De-icers Will Damage Concrete

Custom made steps available



Demolition Call List & Requirements

Site Address: 26 Federal St.

Owner: Michael Morgenstern

Structure Type: Shed

Contractor: _____

Utility Approvals

Central Maine Power

Number

1-800-750-4000

Contact Name/Date

Tanya | 09/13/06

Northern Utilities

797-8002 ext 6241

Mark Allen - 09/13/06

Portland Water District

761-8310

Donna - 09/13/06

Dig Safe

1-888-344-7233

Called - 1 woman I spoke w/ would not give me a contact name as we are not doing any digging. 09/13/06

After calling Dig Safe, you must wait 72 business hours before digging can begin.

not available - late message

DPW/ Traffic Division (L. Cote)

874-8891

L. Cote 09/14/06

09/13/06

DPW/ Sealed Drain Permit (C. Merritt)

874-8822

Carol Merritt - NO sewer attach

Historic Preservation

874-8726

Deb Andrews 09/13/06

Fire Dispatcher

874-8576

Bell 09/13/06

Additional Requirements

- 1) Written Notice to Adjoining Owners N/A
- 2) A Photo of the Structure(s) to be demolished .
- 3) Certification from an asbestos abatement company N/A

DEP – Environmental (Augusta)

287-2651

Sandy Moody 09/13/06

U.S. EPA Region 1 – No Phone call required. Just mail copy of State notification to:

Demo / Reno Clerk
 US EPA Region I (SEA)
 JFK Federal Building
 Boston, MA 02203

I have contacted all of the necessary companies/departments as indicated above and attached all required documentation.

Signed: J. Weychowski

Date: 09/13/06

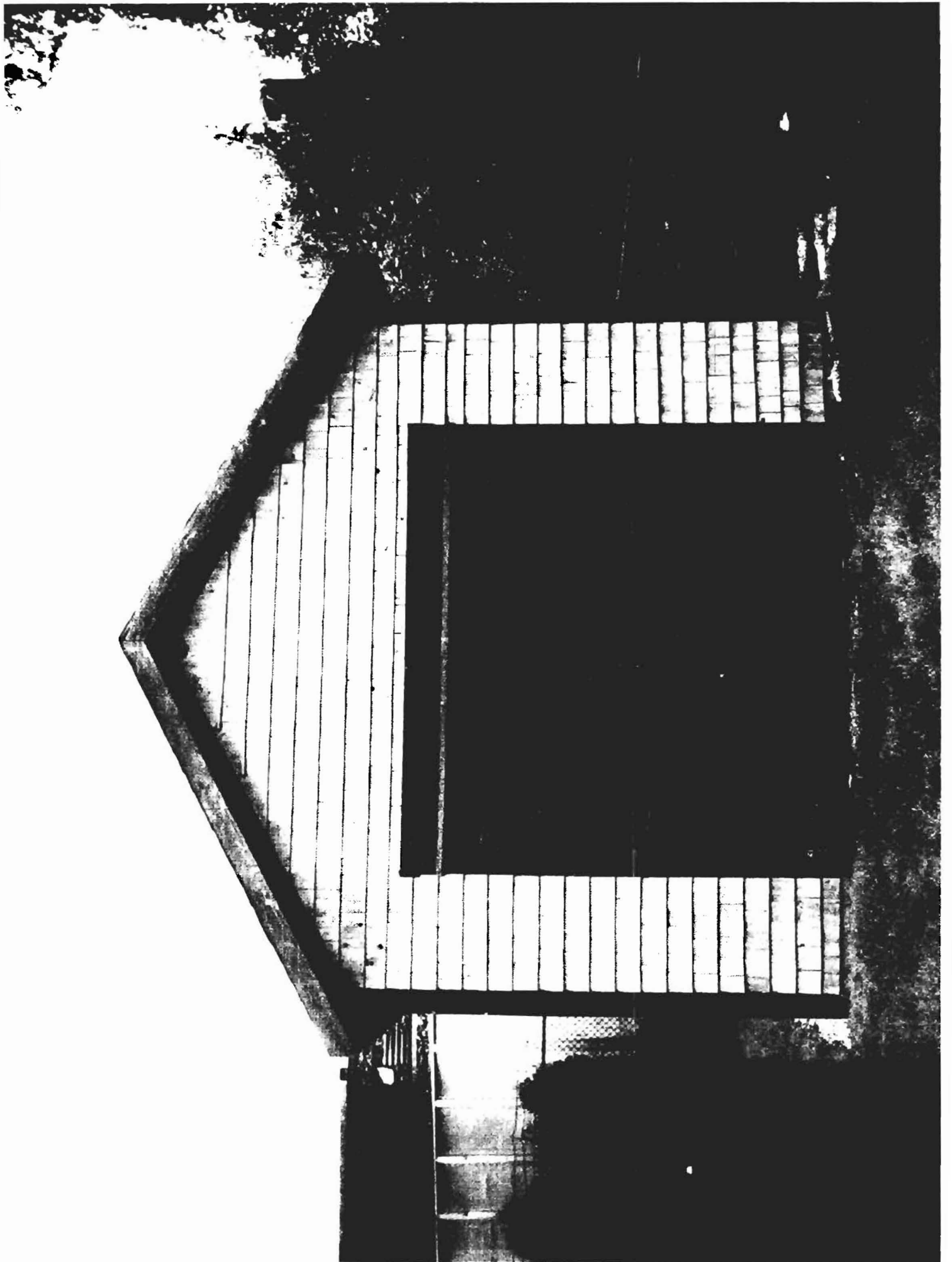

This page contains a detailed description of the Parcel ID you selected. Press the **New Search** button at the bottom of the screen to submit a new query.

Current Owner Information

Card Number	1 of 1
Parcel ID	076 A013001
Location	26 FREDERIC ST
Land Use	THREE FAMILY
Owner Address	MORGENSTERN MICHAEL 26 FREDERIC ST PORTLAND ME 04102
Book/Page	23775/188
Legal	76-A-13 FREDERICK ST 26-28 5000 SF

Current Assessed Valuation

Land	Building	Total
\$67,900	\$152,200	\$220,100

Property Information

Year Built 1905	Style Colonial	Story Height 2	Sq. Ft. 1977	Total Acres 0.115	
Bedrooms 5	Full Baths 3	Half Baths	Total Rooms 11	Attic Full Finsh	Basement Full

Outbuildings

Type GARAGE-WD/CB	Quantity 1	Year Built 1920	Size 14X18	Grade C	Condition A
-----------------------------	----------------------	---------------------------	----------------------	-------------------	-----------------------

Sales Information

Date	Type	Price	Book/Page
03/21/2006	LAND + BLDING	\$329,900	23775-188
06/01/2003	LAND + BLDING	\$201,000	19525-288
01/01/1997	LAND + BLDING	\$78,300	12891-183

Picture and Sketch

[Picture](#) [Sketch](#) [Tax Map](#)

[Click here to view Tax Roll Information.](#)

Any information concerning tax payments should be directed to the Treasury office at 874-8490 or e-mailed.

New Search!



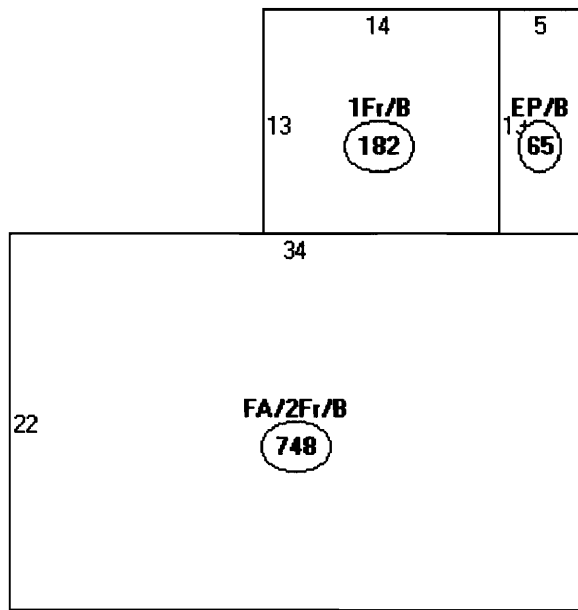

Descriptor/Area

A: FA/2Fr/B
748 sqft

B: 1Fr/B
182 sqft

C: EP/B
65 sqft