

OWNER / DEVELOPER  
**AVESTA HOUSING**  
307 CUMBERLAND AVE.  
PORTLAND, MAINE 04101

PROJECT TITLE  
**LOGAN PLACE  
ACCESSIBILITY UPGRADES**  
PORTLAND MAINE

DRAWING TITLE  
**DETAILS**  
CWS PROJ. NO.: 12442

REVISION DESCRIPTION	DATE

DRAWING NUMBER

**A1.04**

SCALE: 1/4" = 1'-0"  
DATE: 05/20/2013

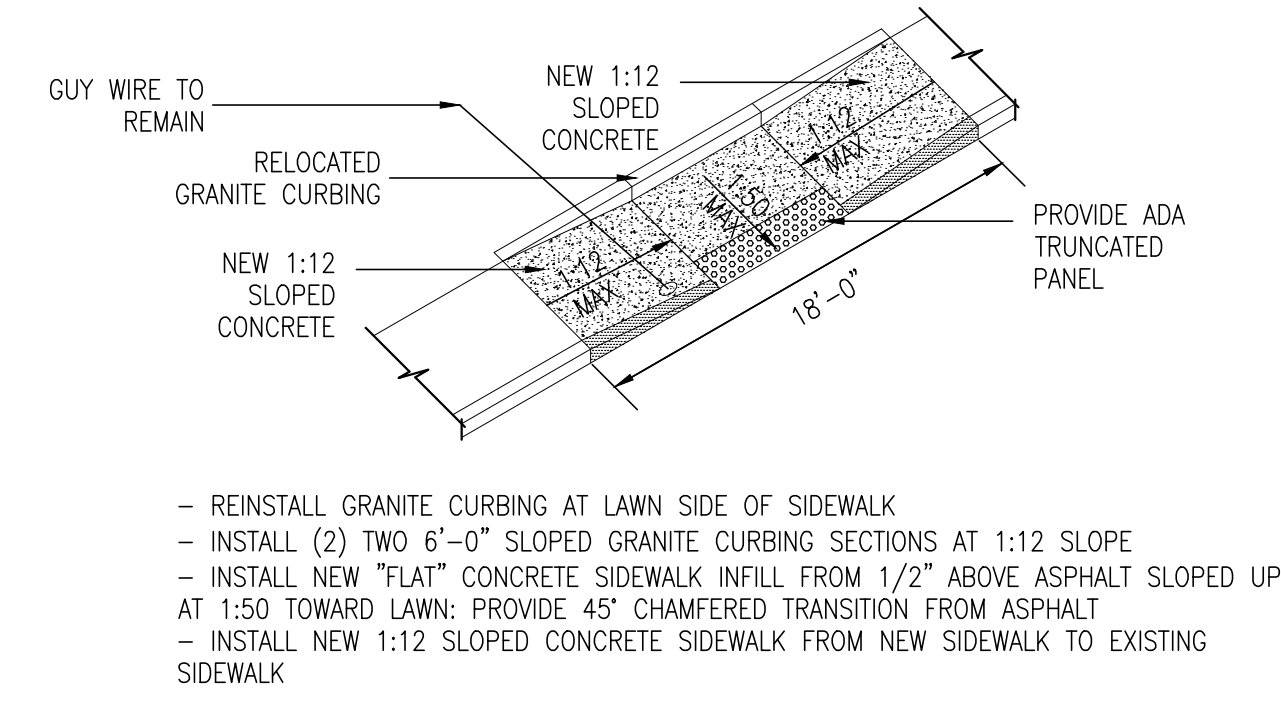
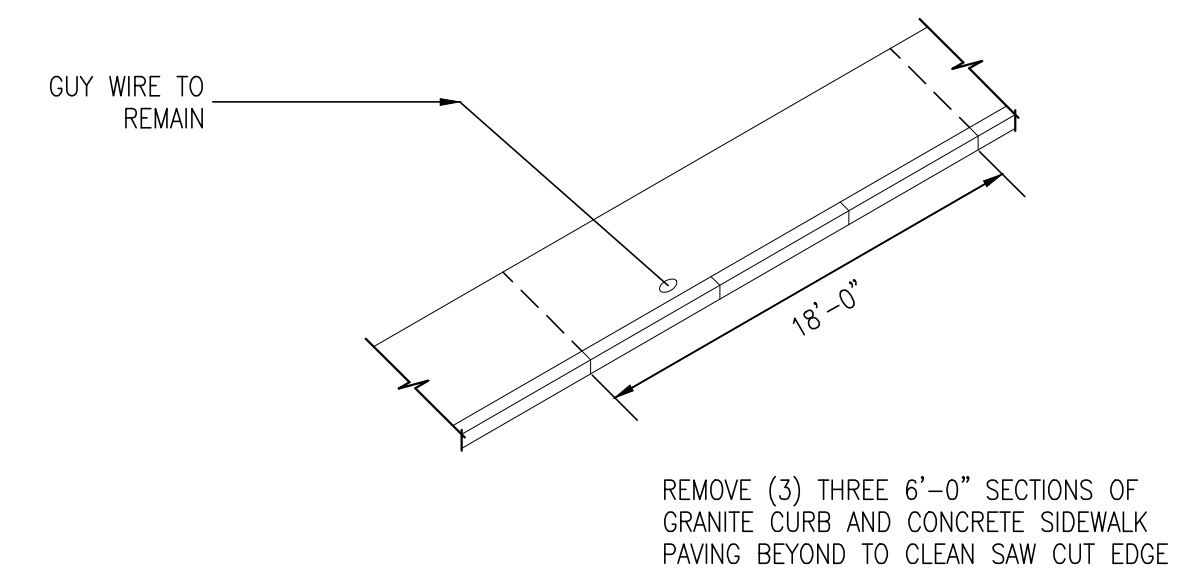

**E3 CURB RAMP DETAIL**  
REFERENCED FROM: SCALE: 1/8"=1'-0"

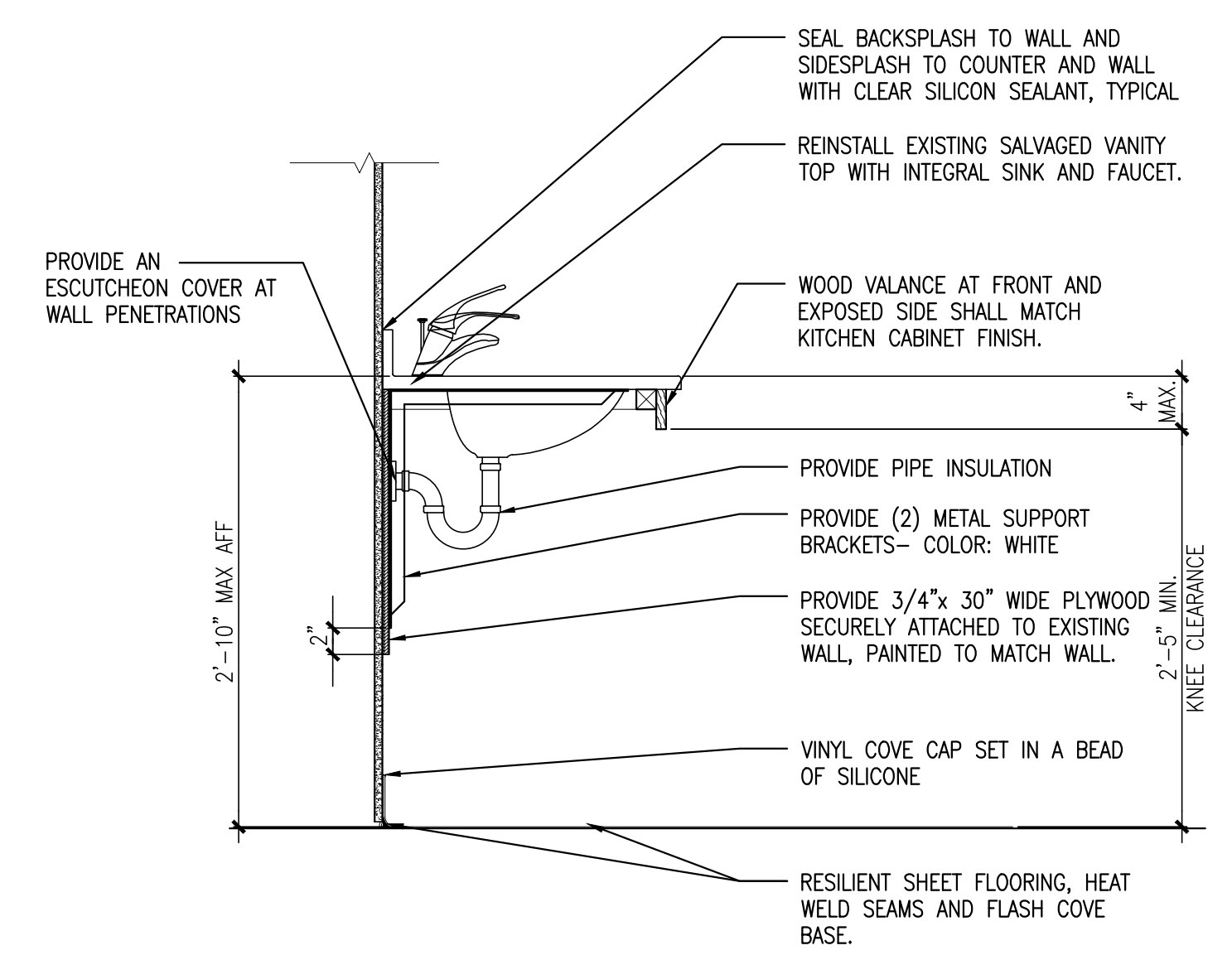

**E5 WALL MOUNTED SINK DETAIL**  
REFERENCED FROM: SCALE: 1"=1'-0"

**A3 CONDOC NAME**  
REFERENCED FROM: SCALE:

**A5 CONDOC NAME**  
REFERENCED FROM: SCALE: