

4 THIRD FLOOR NORTH SHAFT  
SCALE: 1/4\"/>

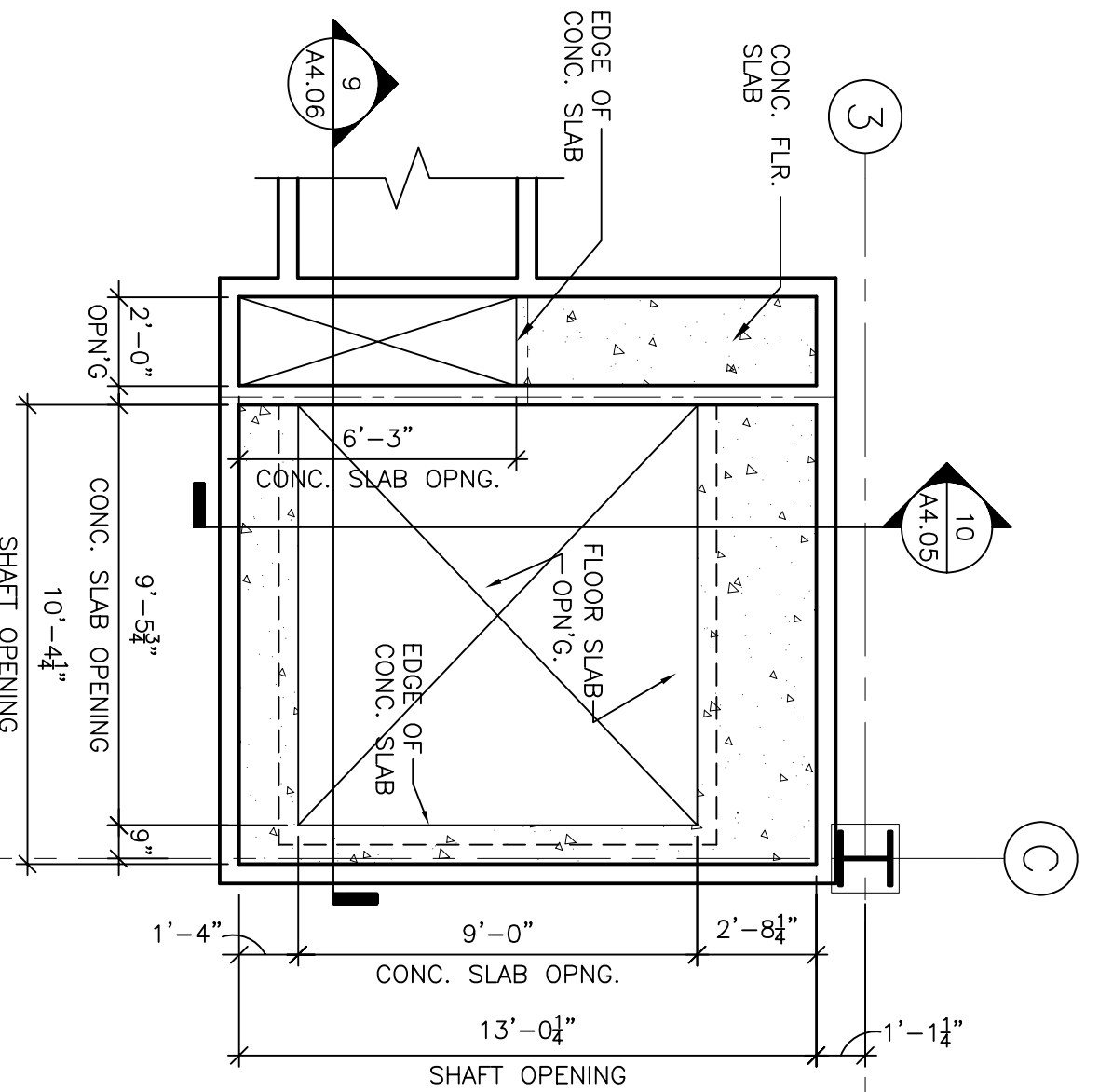

3 SECOND FLOOR NORTH SHAFT  
SCALE: 1/4\"/>

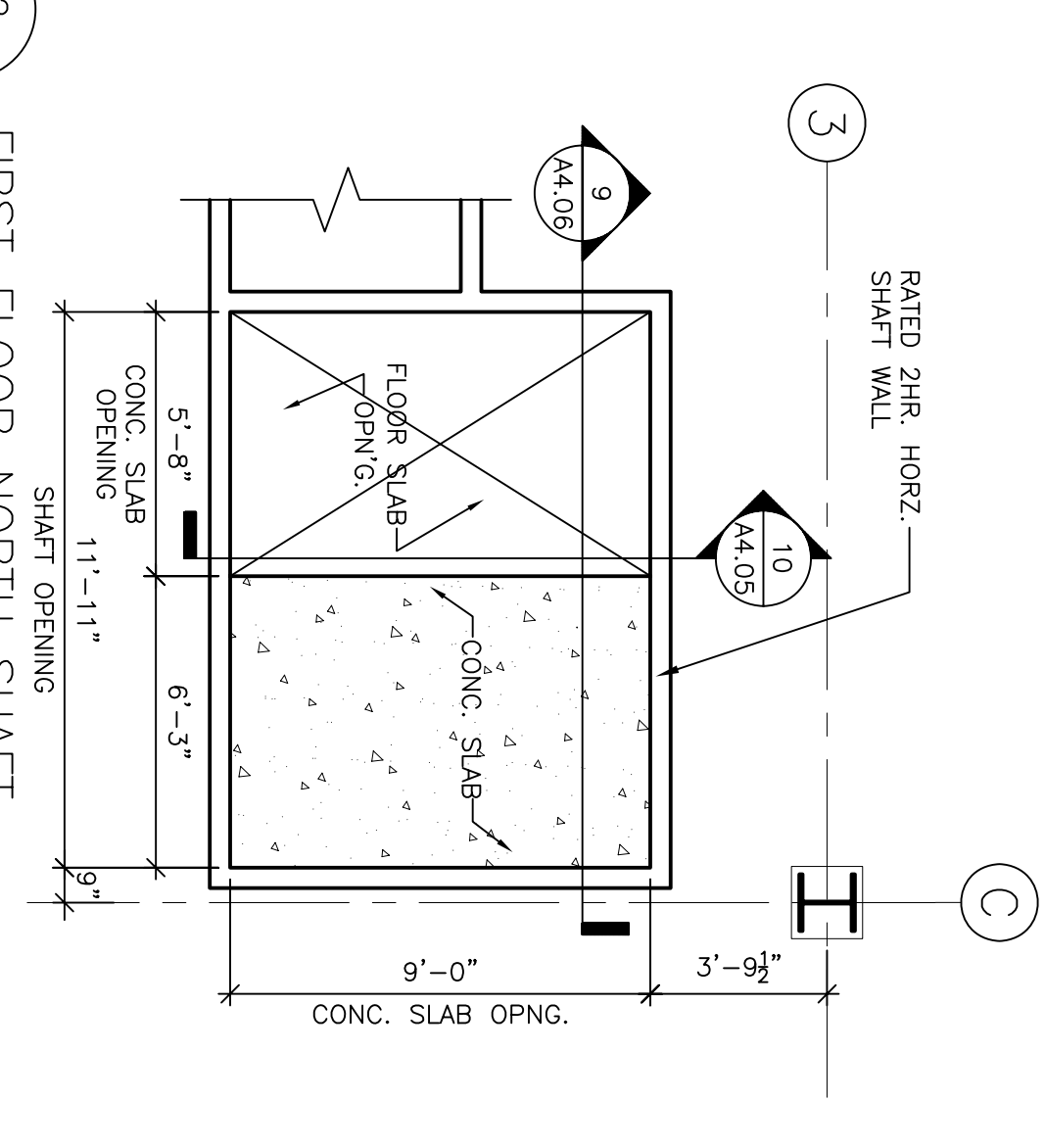

2 FIRST FLOOR NORTH SHAFT  
SCALE: 1/4\"/>

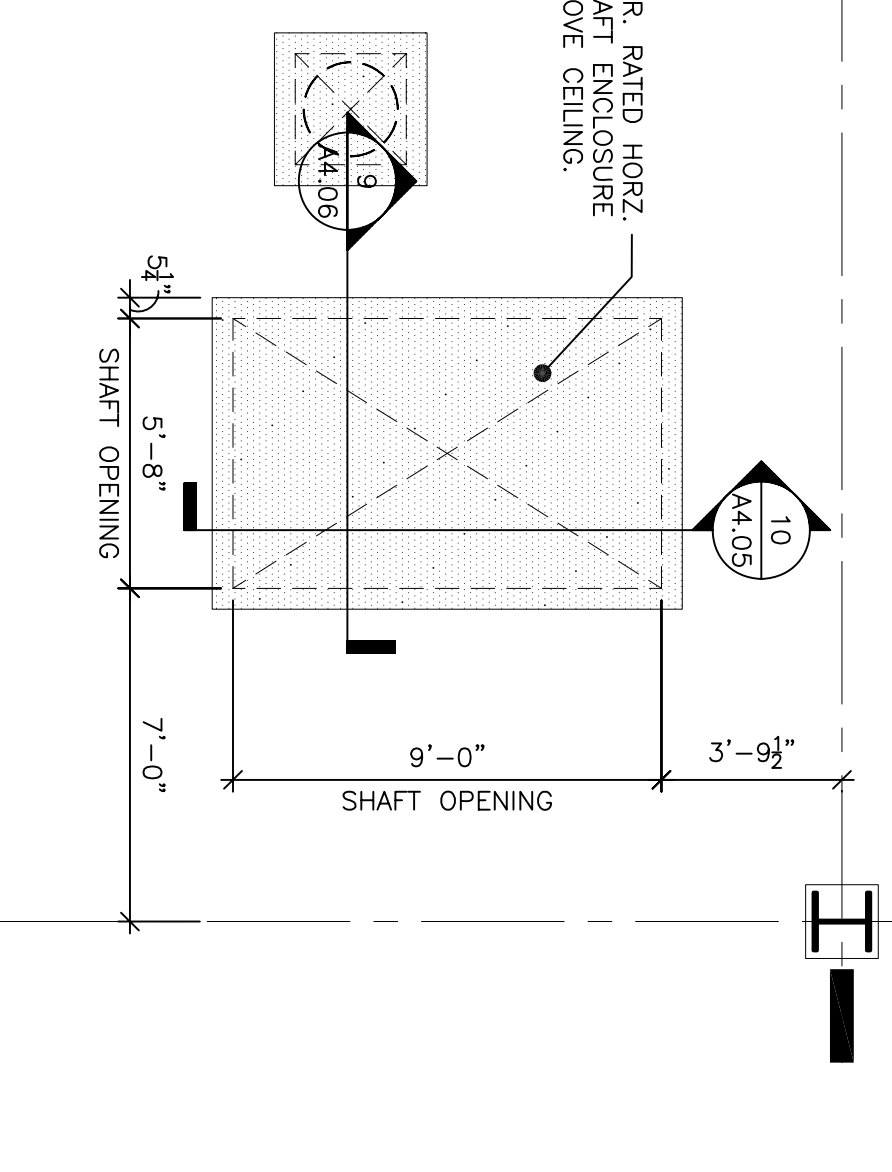

1 GROUND FLOOR NORTH SHAFT ABOVE CEILING  
SCALE: 1/4\"/>

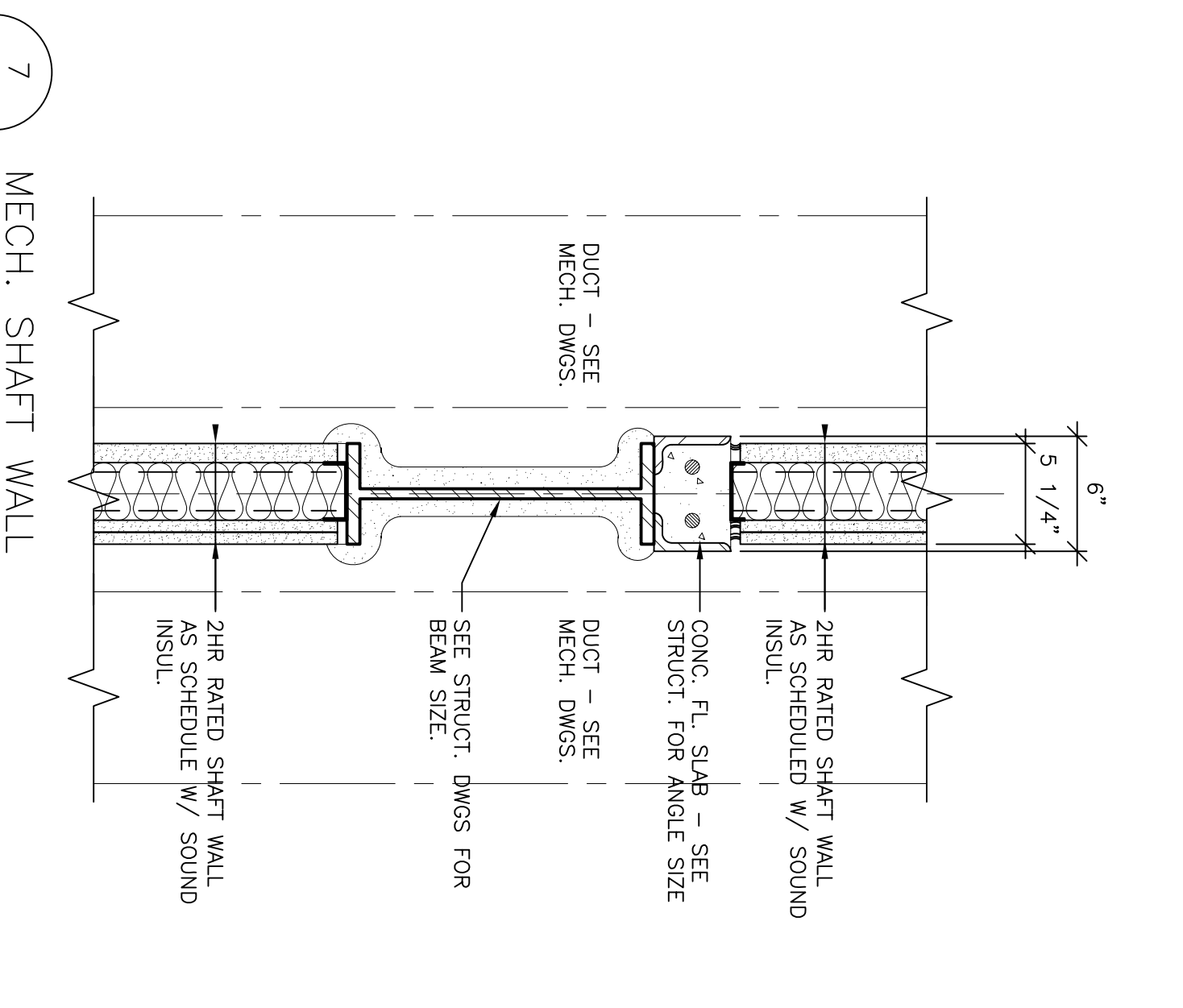

7 MECH. SHAFT WALL  
SCALE: 1 1/2\"/>

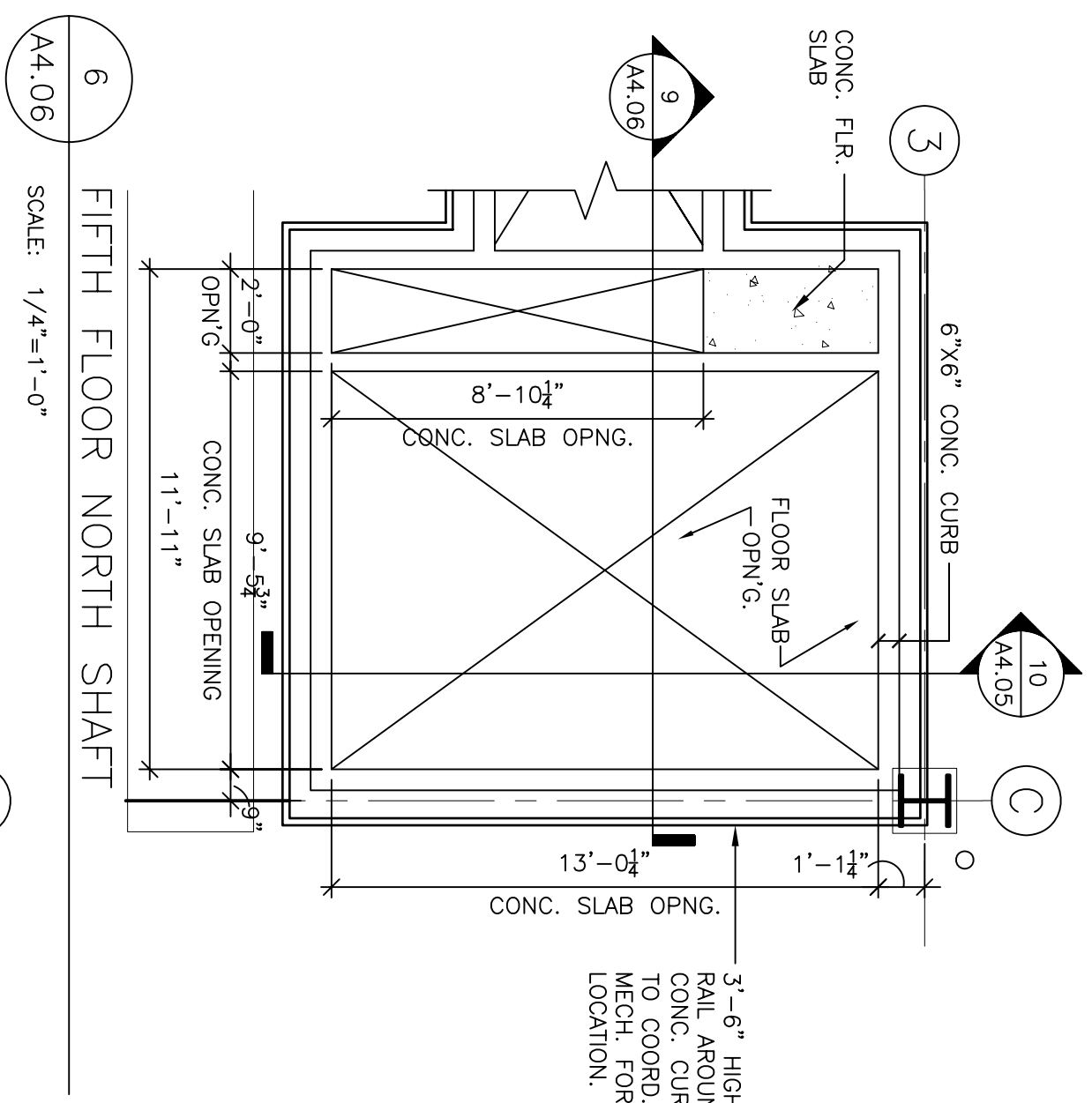

6 FIFTH FLOOR NORTH SHAFT  
SCALE: 1/4\"/>

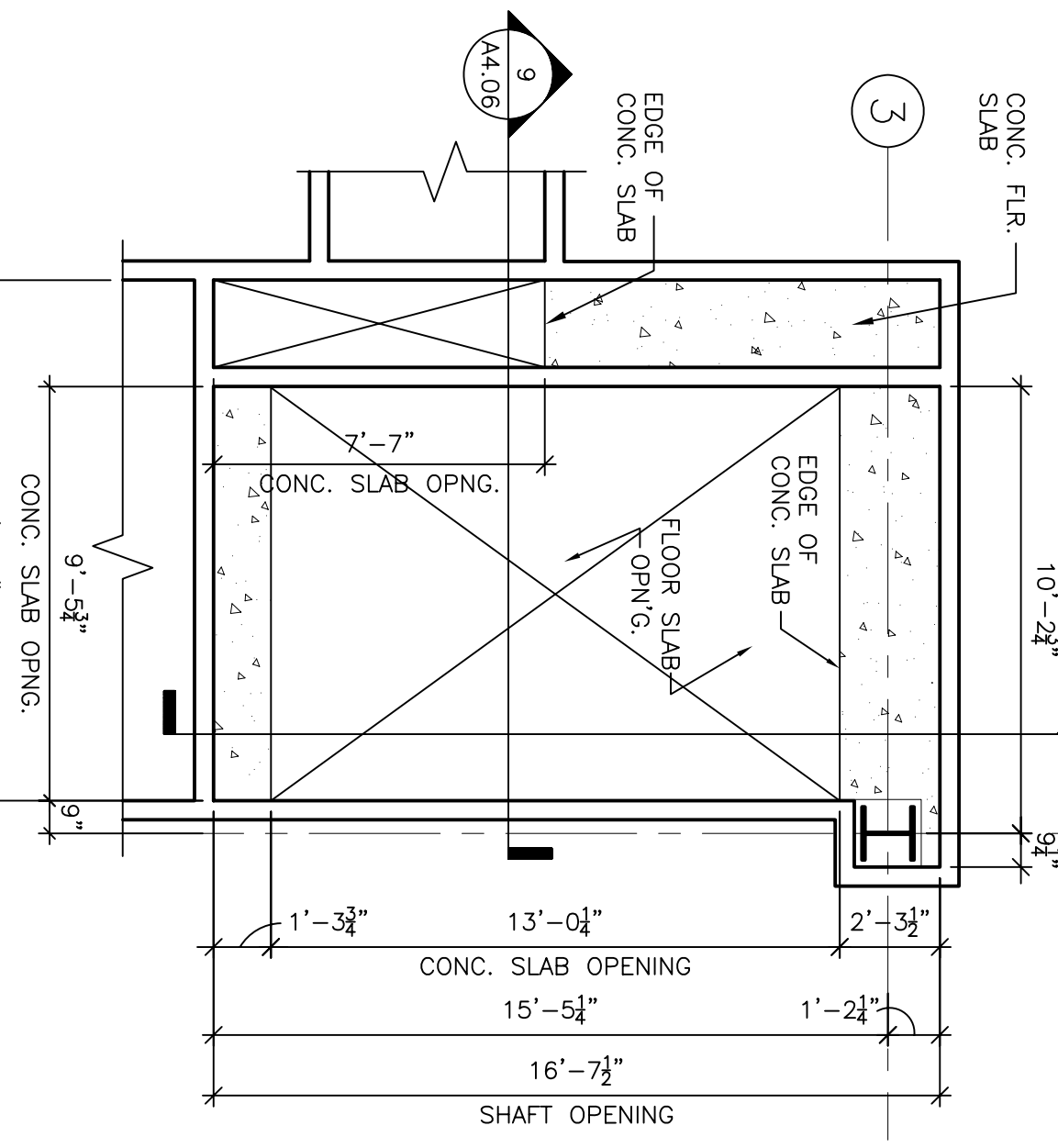

5 FOURTH FLOOR NORTH SHAFT  
SCALE: 1/4\"/>

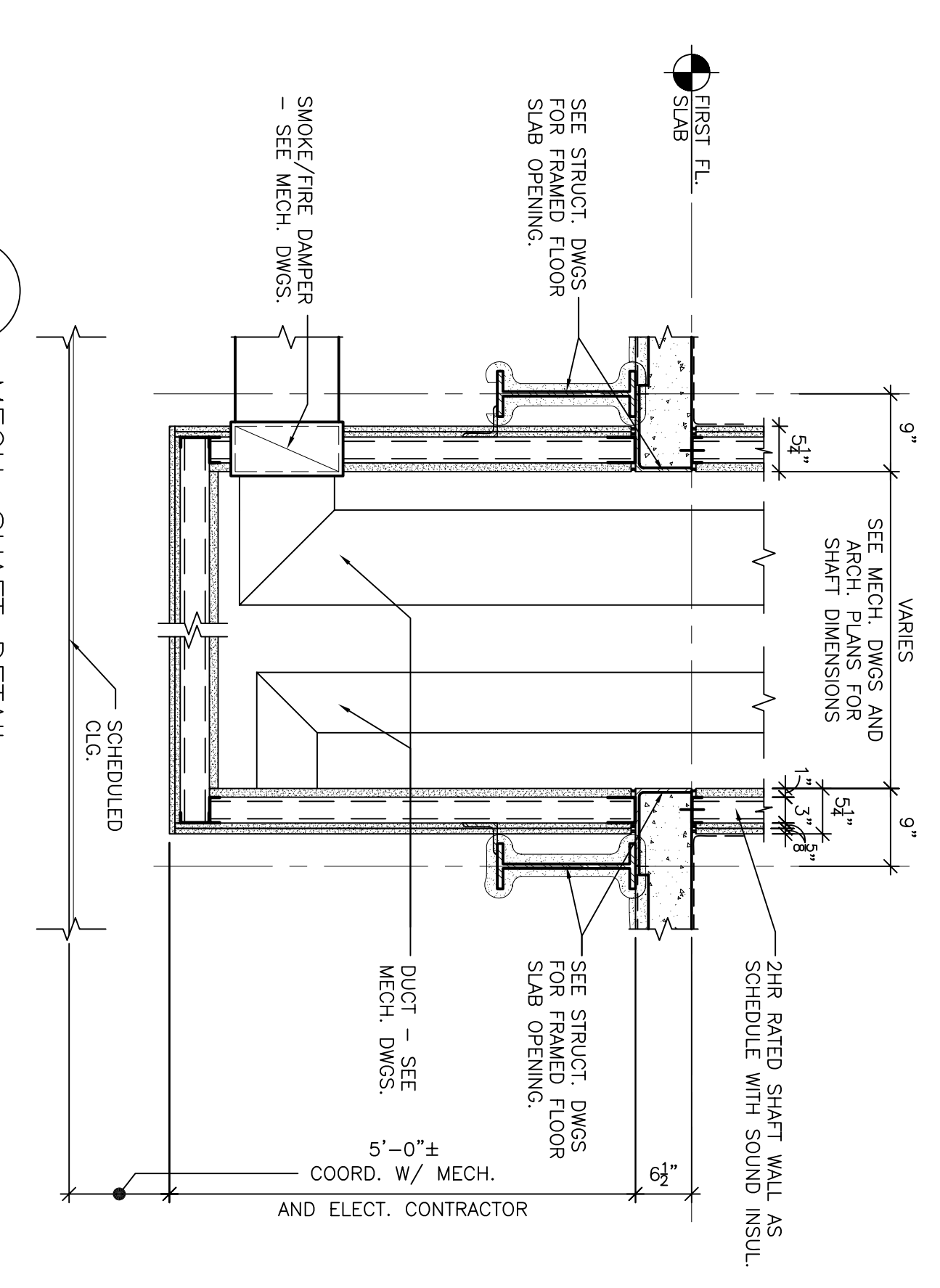

8 MECH. SHAFT DETAIL  
SCALE: 3/4\"/>

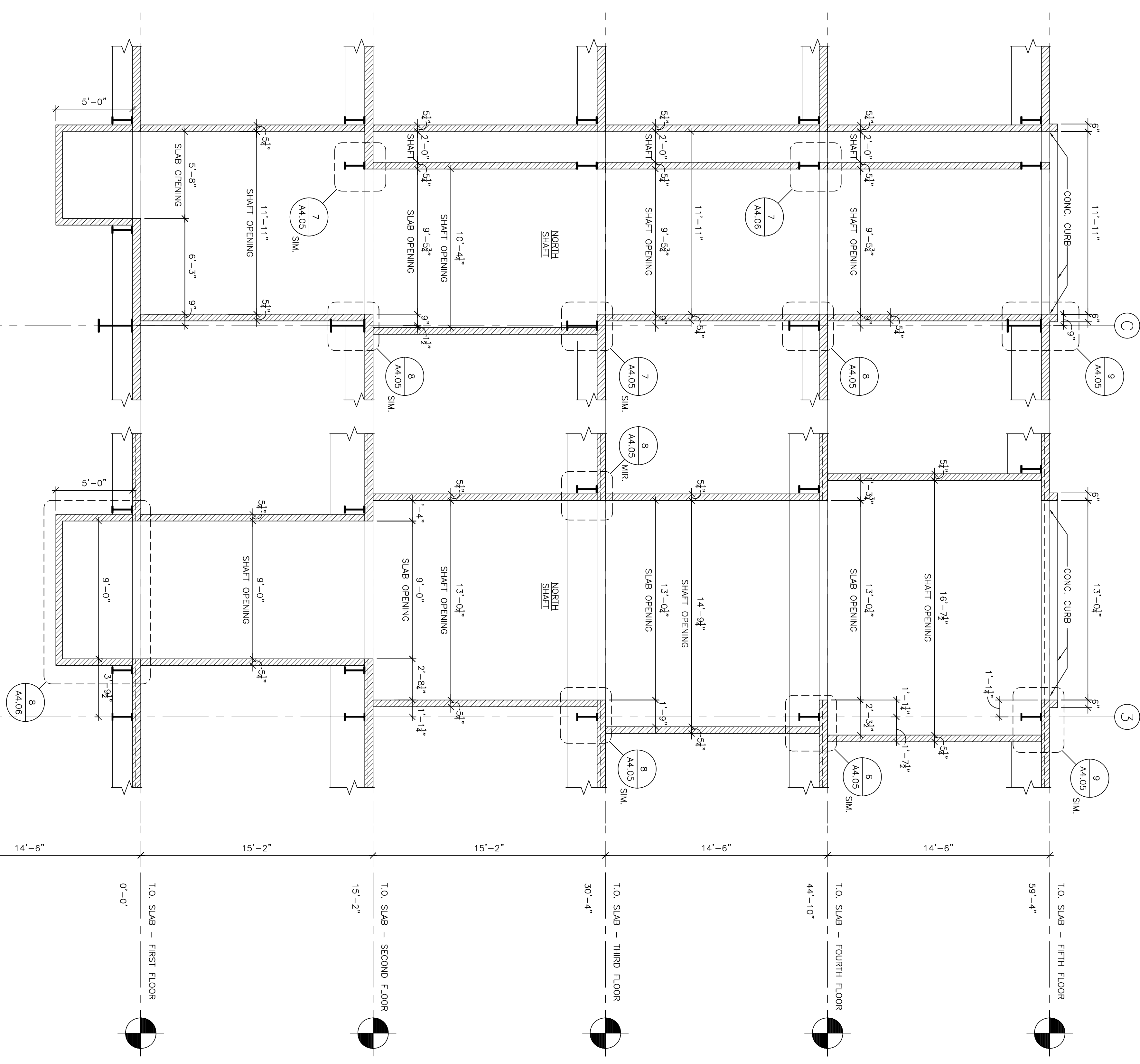

9 SECTION THROUGH NORTH SHAFT  
SCALE: 1/4\"/>

10 SECTION THROUGH NORTH SHAFT  
SCALE: 1/4\"/>

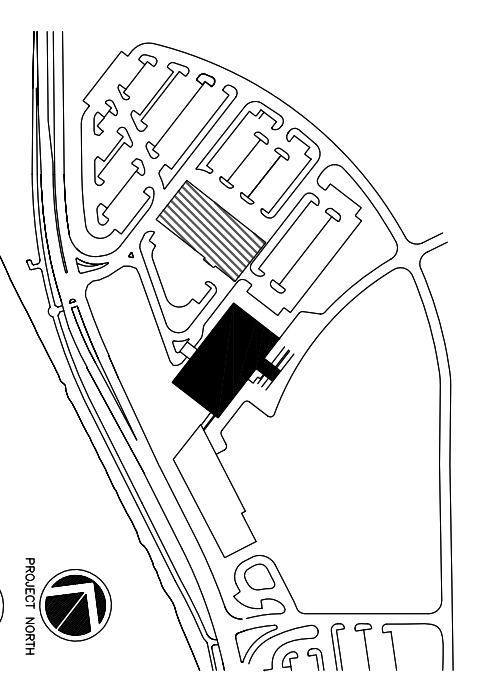

Revisions

Consultant  
 CIVIL ENGINEER  
 MCMC Architects/Structural Engineer  
 144 Fore Street P.O. Box 618  
 Portland, ME 04103  
 Phone: (207) 772-2846  
 Fax: (207) 772-1070

Consultant  
 MECHANICAL/ELECTRICAL ENGINEER  
 Burd, Roe & Athous Consulting Engineers, LLC  
 311 Kennel Street  
 Woburn, MA 02472-5789  
 Phone: (617) 224-9399  
 Fax: (617) 224-9399

Consultant  
 EQUIPMENT PLANNING  
 Equi-Burton & Associates  
 2000 West End Ave. Suite 1400  
 Franklin, Tennessee 37067  
 Phone: (615) 221-5991  
 Fax: (615) 221-5991

Consultant  
 CONSTRUCTION MANAGER  
 7 Jackson Walkway  
 Providence, Rhode Island 02903  
 Phone: (401) 458-5516  
 Fax: (401) 458-5516

Consultant  
 FOOD SERVICE  
 Food Service, LLC  
 1808 West End Ave. Suite 1400  
 Franklin, Tennessee 37067  
 Phone: (615) 321-5991  
 Fax: (615) 321-5991

10.02.06 CORE & SHELL ISSUED FOR CONSTRUCTION  
 Drawn By: MAF/JLV/CLB/CLU/LMS  
 Scale: AS NOTED

Francis  
 Cauffman  
 Foley

Hoffmann

Mercy Health  
 System of Maine  
 FORE RIVER SHORT  
 STAY HOSPITAL

Project Number  
 F05-4898

Project Title  
 Fore River Short Stay Hospital

Francis Cauffman  
 Foley Hoffmann  
 Architects Ltd.  
 210 Acorn Street  
 Philadelphia, PA 19103  
 Phone: (215) 968-8250

210 Acorn Street  
 Philadelphia, PA 19103  
 Phone: (215) 968-8250

210 Acorn Street  
 Philadelphia, PA 19103  
 Phone: (215) 968-8250

210 Acorn Street  
 Philadelphia, PA 19103  
 Phone: (215) 968-8250

210 Acorn Street  
 Philadelphia, PA 19103  
 Phone: (215) 968-8250

210 Acorn Street  
 Philadelphia, PA 19103  
 Phone: (215) 968-8250

210 Acorn Street  
 Philadelphia, PA 19103  
 Phone: (215) 968-8250

210 Acorn Street  
 Philadelphia, PA 19103  
 Phone: (215) 968-8250

210 Acorn Street  
 Philadelphia, PA 19103  
 Phone: (215) 968-8250