

Consultant  
 CIVIL ENGINEER  
 RMC Engineers Associates, Inc.  
 278 Main Street, Suite 806  
 Portland, Tennessee 37087  
 Phone: (207) 772-1121  
 Fax: (207) 879-0886

Consultant  
 MECHANICAL/ELECTRICAL ENGINEER  
 Bert, Roe & Atkins Consulting Engineers, LLC  
 311 Arsenal Street, Charles  
 Woodstock, VA 02072-5789  
 Phone: (540) 592-1116  
 Fax: (540) 592-1117

Consultant  
 EQUIPMENT PLANNING  
 Sage Burton & Associates  
 144 Fore Street P.O. Box 618  
 Portland, Tennessee 37087  
 Phone: (207) 772-3846  
 Fax: (207) 772-1070

Consultant  
 CONSTRUCTION MANAGER  
 7 Jackson Walkway  
 Providence, Rhode Island 02903  
 Phone: (401) 458-5516  
 Fax: (401) 458-5516

Consultant  
 FLOOR FINISHES  
 RMC Services, LLC  
 1808 West End Ave, Suite 1400  
 Portland, Tennessee 37087  
 Phone: (615) 321-5591  
 Fax: (615) 321-5689

Date  
 10.02.06  
 CORE & SHELL ISSUED  
 FOR CONSTRUCTION

Drawn By  
 MAF/JLV/CJB/CLV/LMS

Scale  
 AS NOTED

Francis

Cauffman

Foley

Hoffmann

Project Title  
 Mercy Health  
 System of Maine  
 FORE RIVER SHORT  
 STAY HOSPITAL

Project Location  
 Francis Cauffman  
 Foley Hoffmann  
 Architects Ltd.  
 2120 Acorn Street  
 Philadelphia, PA 19103  
 Phone: (215) 568-8250



Project Number  
 F05-4898

Drawing Title and Number  
 Elevator Plans and Sections

A4.04

NOTE  
 LAUNDRY CHUTE  
 CONC. SLAB OPNG.  
 FRAMING - SEE STRUCT.  
 DWGS.

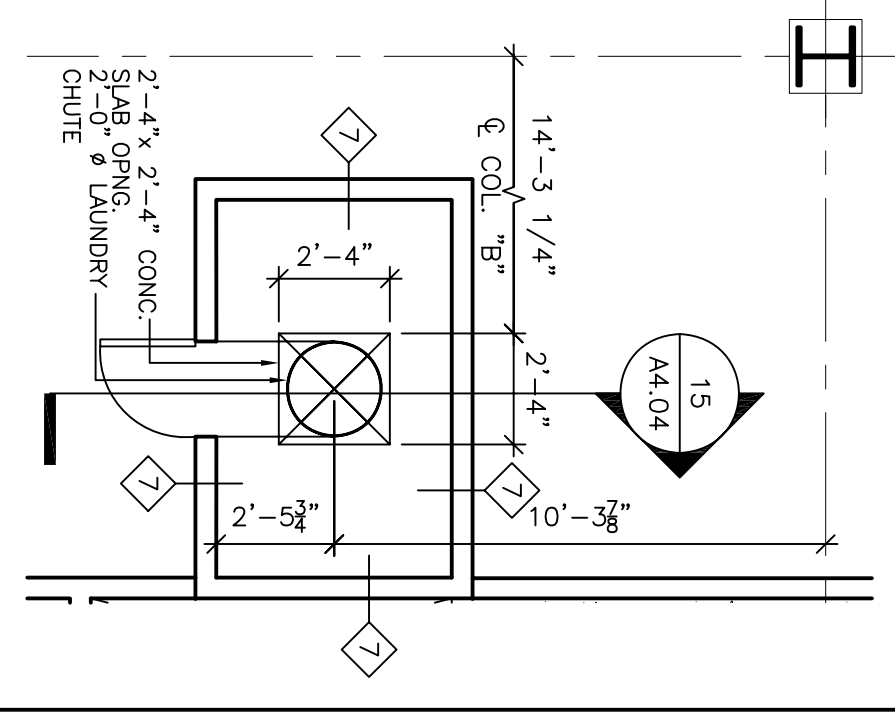

12  
 LAUNDRY CHUTE  
 FOURTH FLOOR  
 SCALE: 1/4"=1'-0"

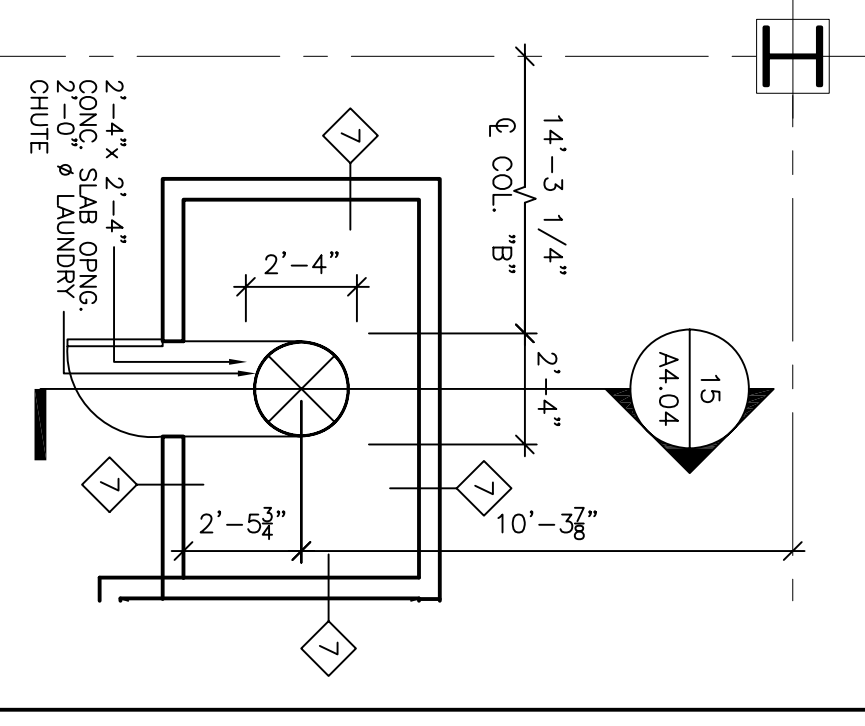

11  
 LAUNDRY CHUTE  
 THIRD FLOOR  
 SCALE: 1/4"=1'-0"

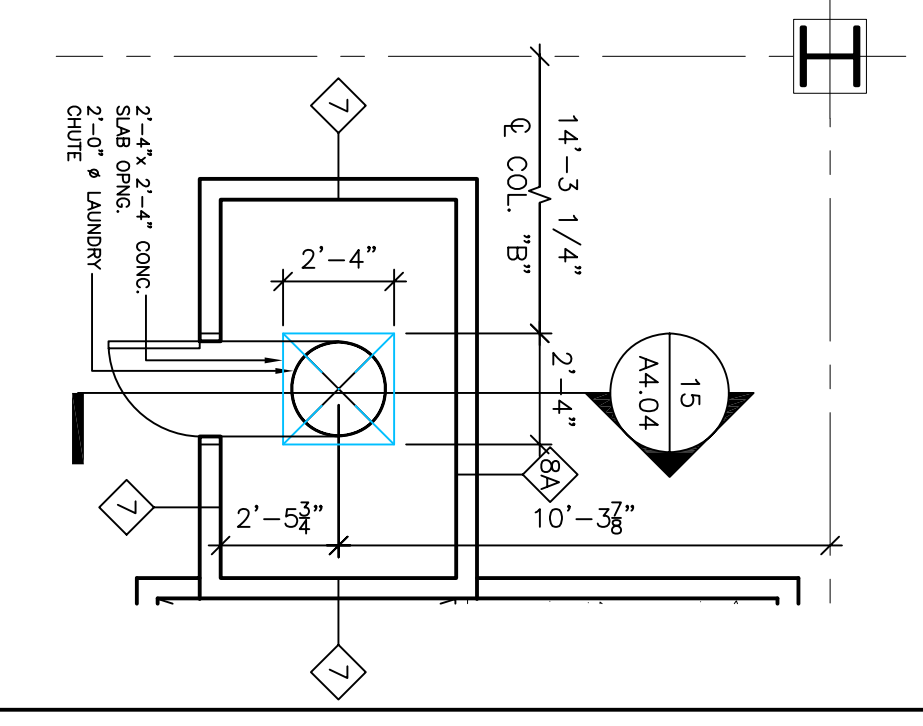

10  
 LAUNDRY CHUTE  
 SECOND FLOOR  
 SCALE: 1/4"=1'-0"

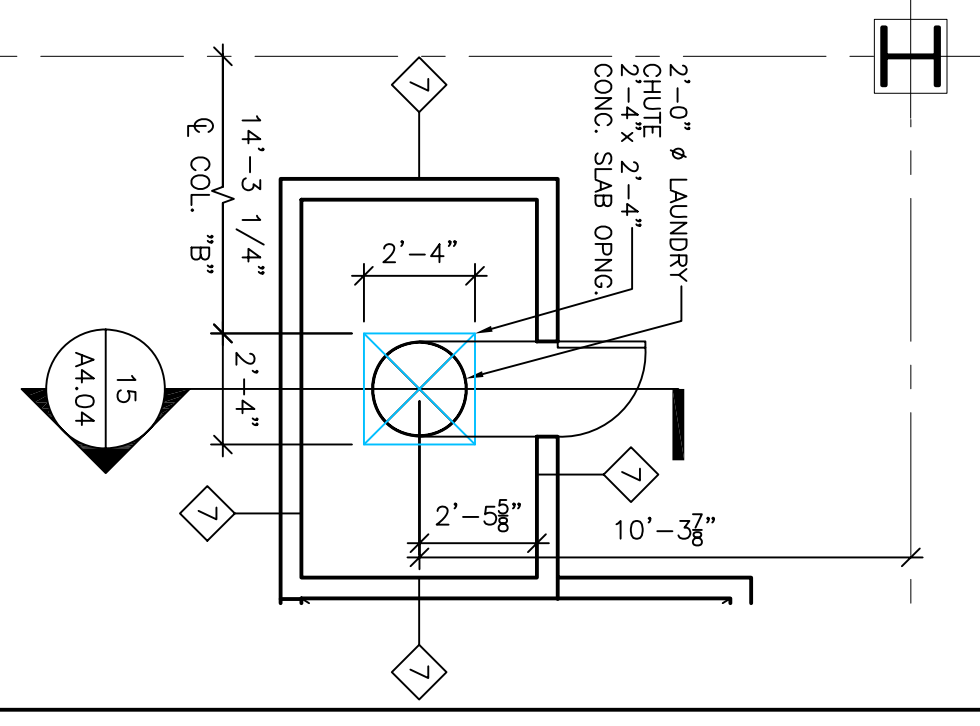

9  
 LAUNDRY CHUTE  
 FIRST FLOOR  
 SCALE: 1/4"=1'-0"

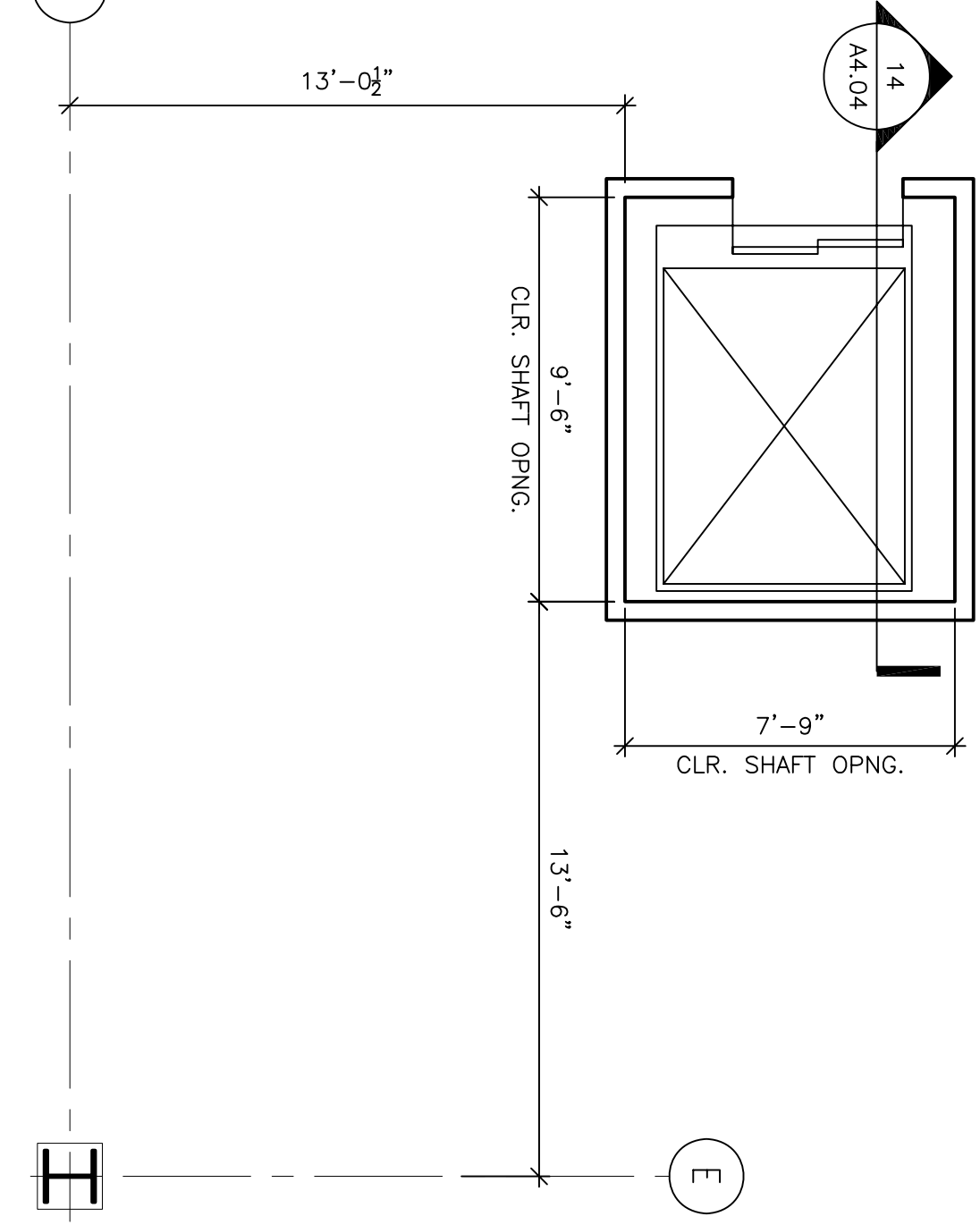

8  
 CLEAN ELEVATOR #6  
 SECOND FLOOR  
 SCALE: 1/4"=1'-0"

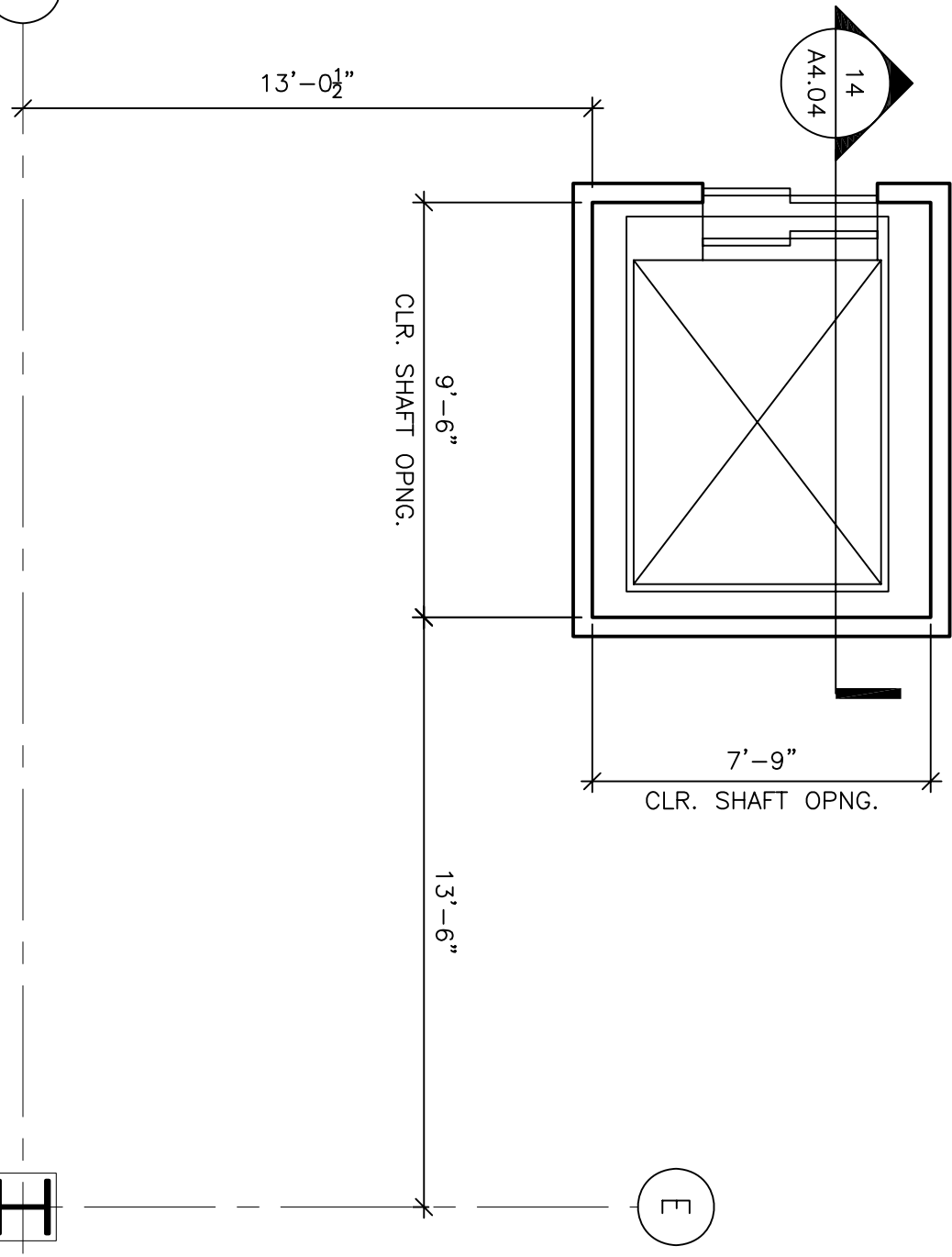

7  
 CLEAN ELEVATOR #6  
 FIRST FLOOR  
 SCALE: 1/4"=1'-0"

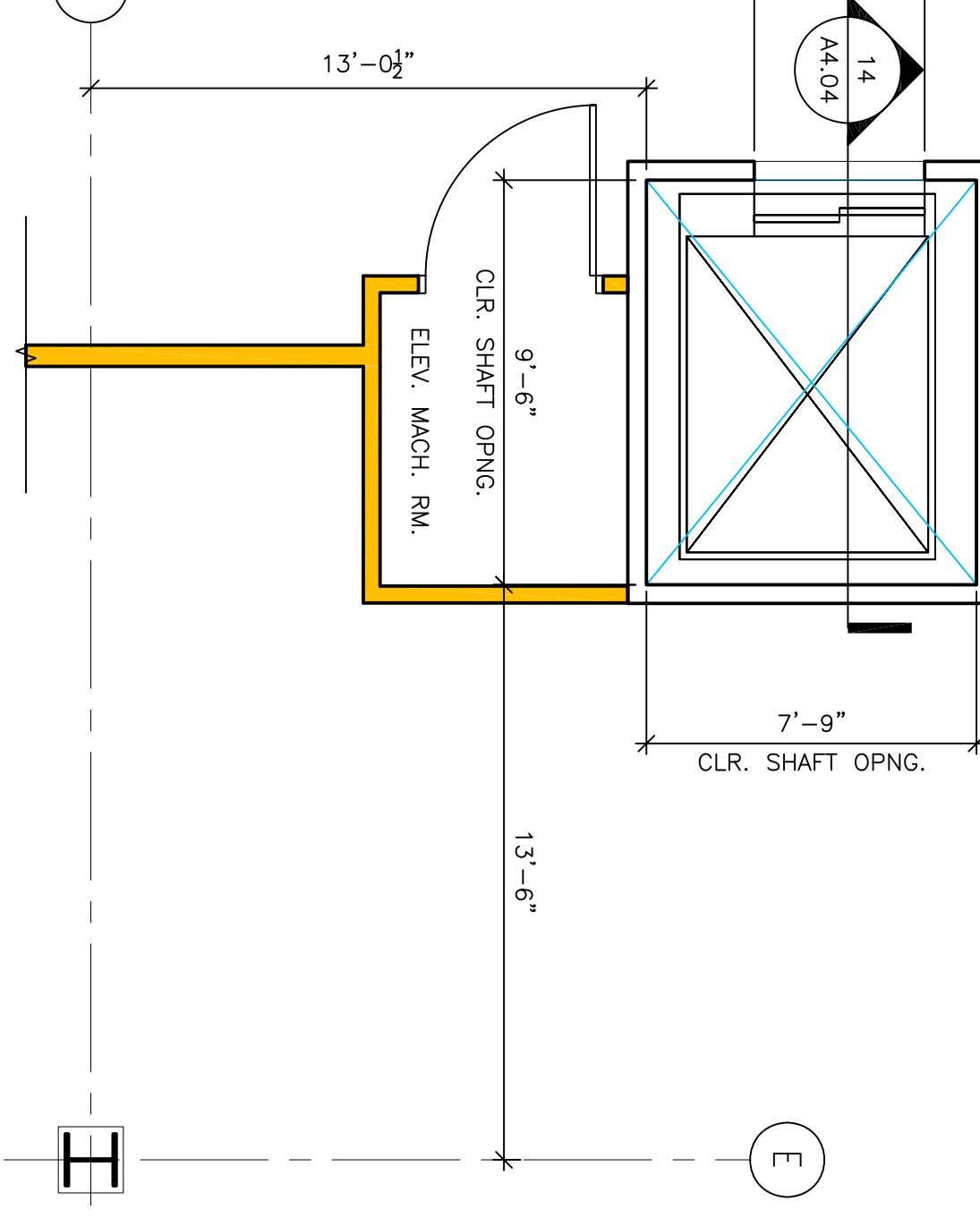

6  
 CLEAN ELEVATOR #6  
 GROUND FLOOR  
 SCALE: 1/4"=1'-0"

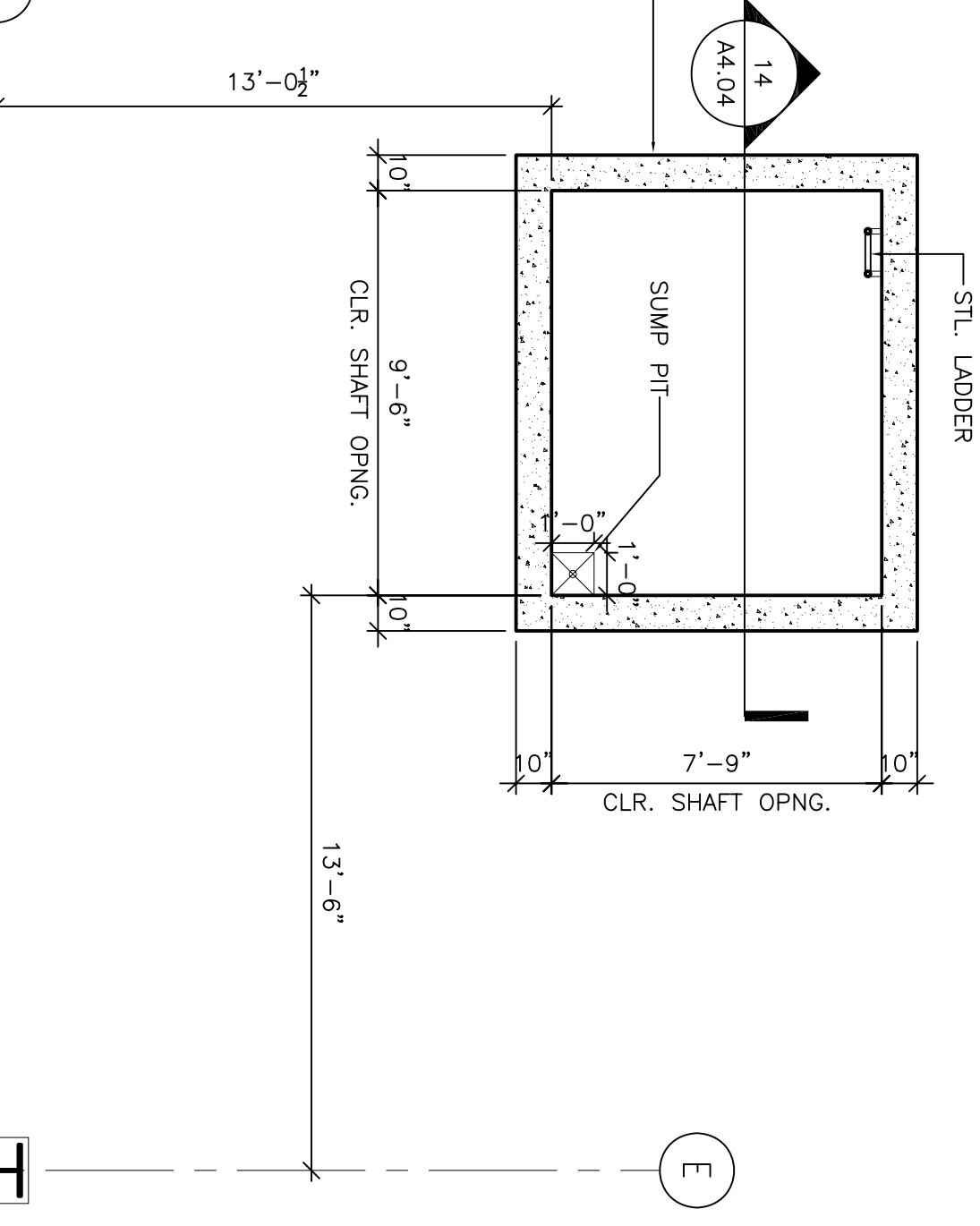

5  
 CLEAN ELEVATOR #6  
 GROUND FLOOR PIT  
 SCALE: 1/4"=1'-0"

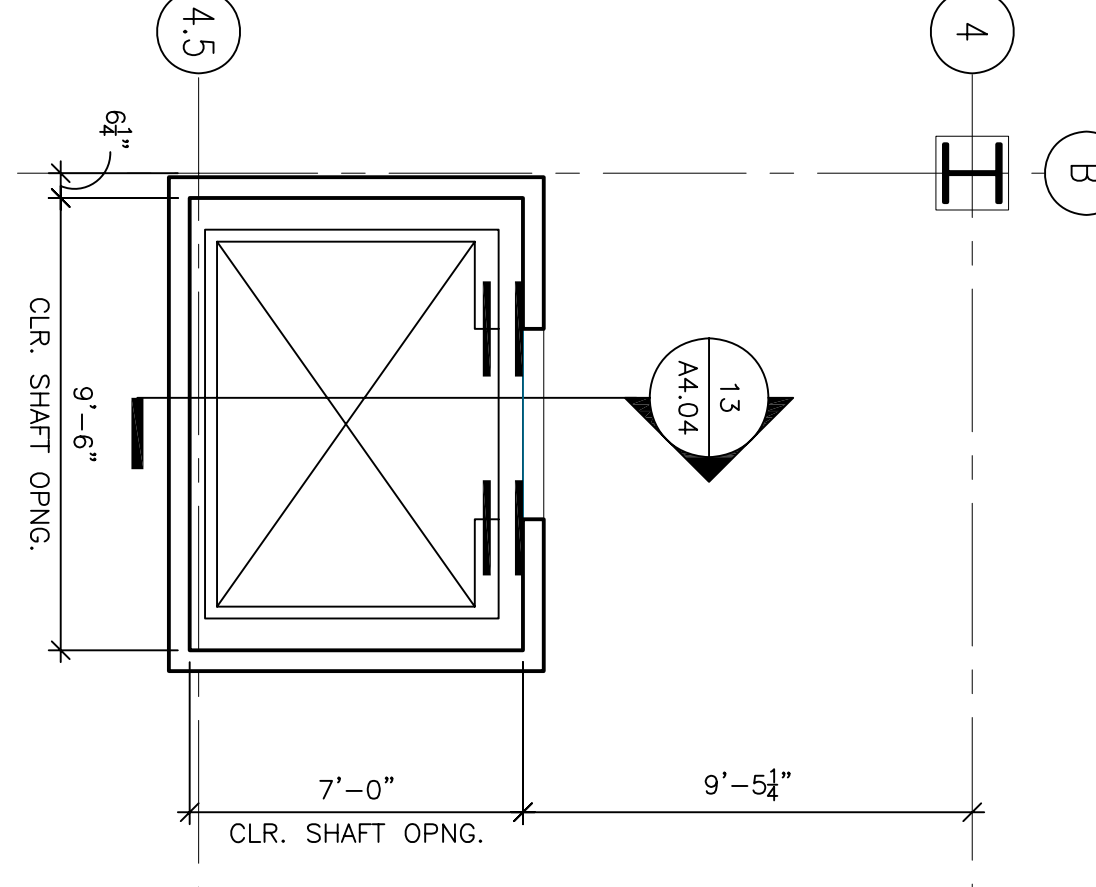

4  
 SOILED ELEVATOR #5  
 SECOND FLOOR  
 SCALE: 1/4"=1'-0"

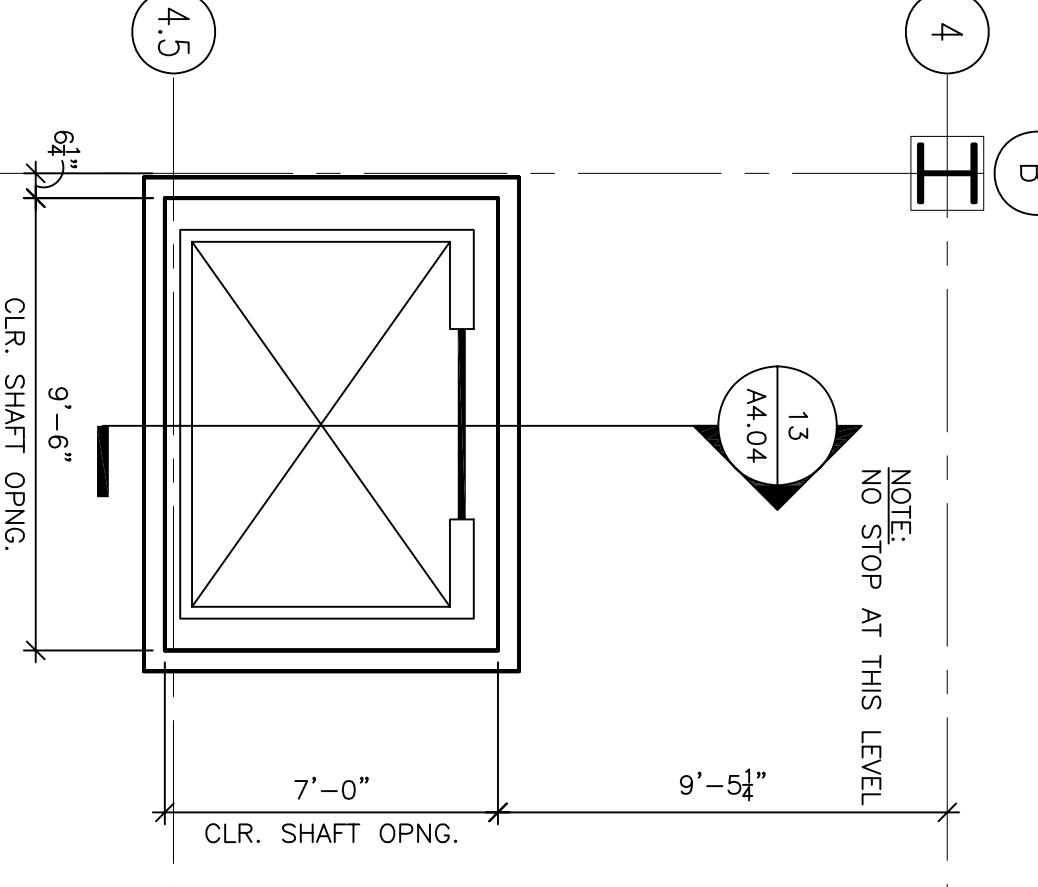

3  
 SOILED ELEVATOR #5  
 FIRST FLOOR  
 SCALE: 1/4"=1'-0"

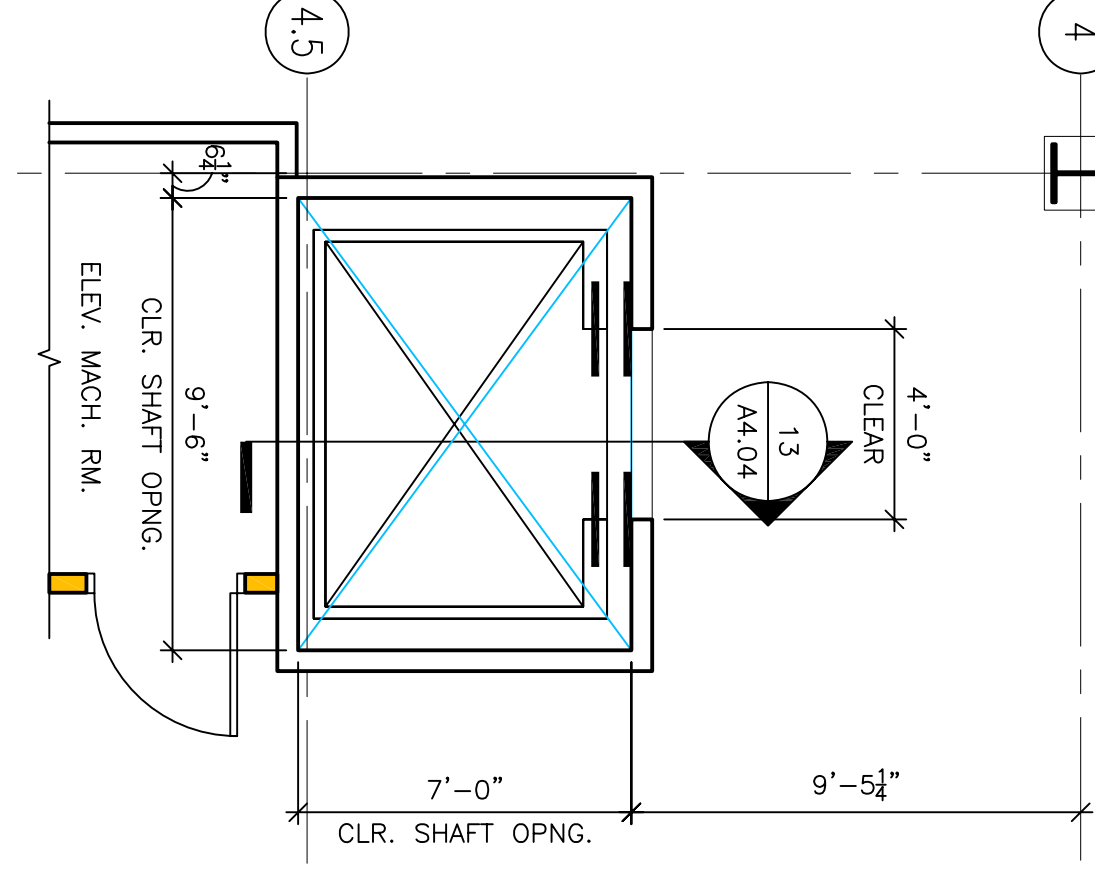

2  
 SOILED ELEVATOR #5  
 GROUND FLOOR  
 SCALE: 1/4"=1'-0"

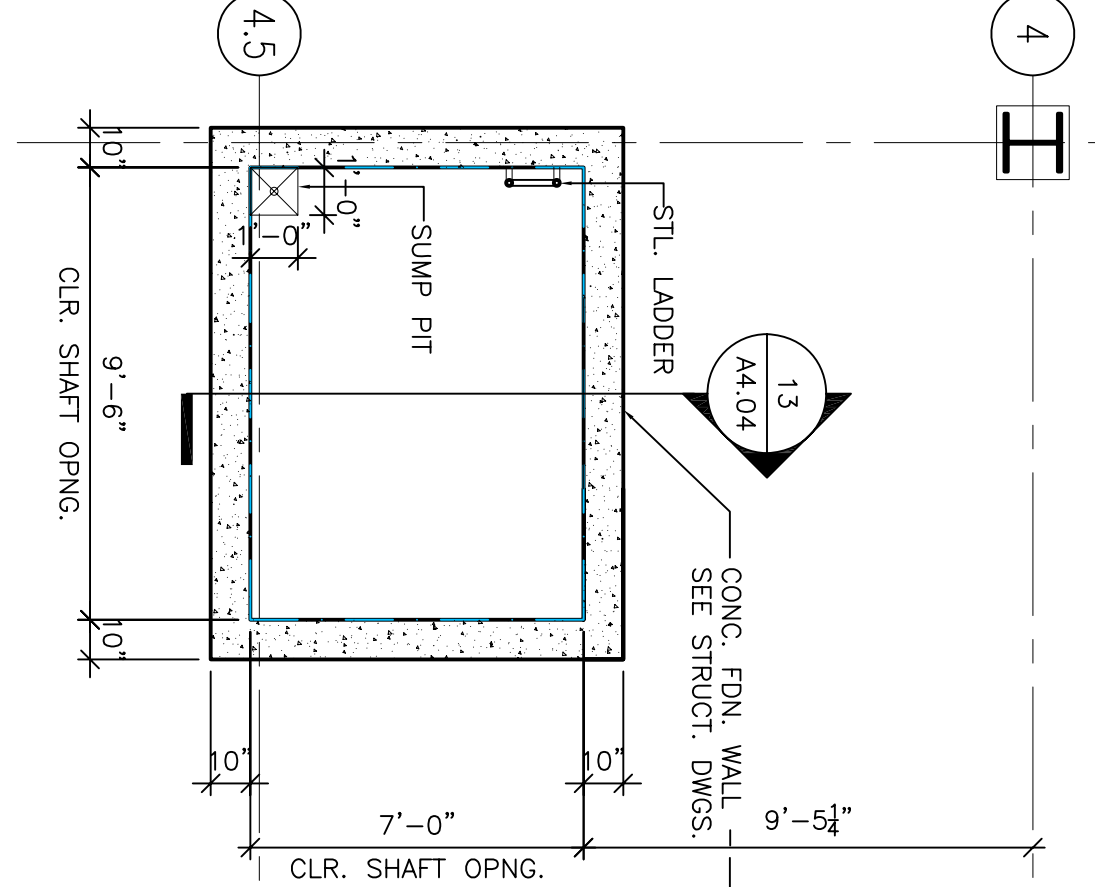

1  
 SOILED ELEVATOR #5  
 GROUND FLOOR PIT  
 SCALE: 1/4"=1'-0"

EXPANSION  
 ABOVE  
 FINISH  
 ROOF

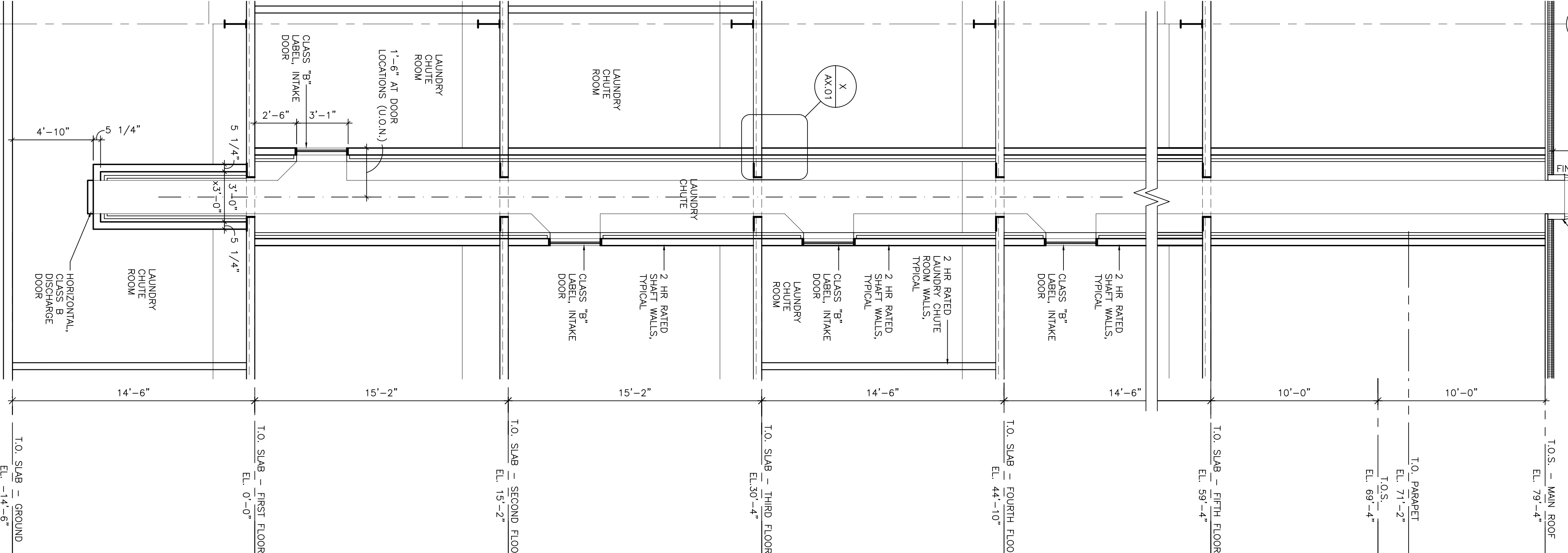

15  
 LAUNDRY CHUTE SECTION  
 SCALE: 1/4"=1'-0"

14  
 CLEAN ELEVATOR  
 UTILITY SECTION  
 SCALE: 1/4"=1'-0"

13  
 SOILED ELEVATOR  
 UTILITY SECTION  
 SCALE: 1/4"=1'-0"

CLEAR HOLE DEPTH =  
 RISE PLUS 8'-0"  
 MINUS THE PIT DEPTH

CLEAR HOLE DEPTH =  
 RISE PLUS 8'-0"  
 MINUS THE PIT DEPTH