

**City of Portland, Maine - Building or Use Permit Application**

389 Congress Street, 04101 Tel: (207) 874-8703, Fax: (207) 874-8716

Permit No: 05-1550	Issue Date: NOV 4 2005	CEB: 069-A007001
<b>PERMIT ISSUED</b>		
Owner Address: 22 CHADWICK ST	Contractor Address: 629 Main St. Gorham	Phone: 2078567000
Permit Type: HVAC	Zone: E3	

Location of Construction: 22 CHADWICK ST	Owner Name: HIATT DAVID B & GWEN KEIG
Business Name:	Contractor Name: Frost N Flame
Lessee/Buyer's Name	Phone:

Past Use: Single Family Home	Proposed Use: Single Family Home/ Gas unit in fireplace
---------------------------------	--

Permit Fee: \$57.00	Cost of Work: \$3,756.00	CEO District: 2
FIRE DEPT: <input checked="" type="checkbox"/> Approved <input type="checkbox"/> Denied To N&PA 54	INSPECTION: Use Group: CA Type: HVAC STATE ME GAS Regulations	
Signature: <i>[Signature]</i>	Signature:	
PEDESTRIAN ACTIVITIES DISTRICT (P.A.D.)		
Action: <input type="checkbox"/> Approved <input type="checkbox"/> Approved w/Conditions <input type="checkbox"/> Denied		
Signature:	Date:	

Proposed Project Description:  
Gas unit in fireplace

Permit Taken By: Idobson	Date Applied For: 10/21/2005	<b>Zoning Approval</b>		
<p>1. This permit application does not preclude the Applicant(s) from meeting applicable State and Federal Rules.</p> <p>2. Building permits do not include plumbing, septic or electrical work.</p> <p>3. Building permits are void if work is not started within six (6) months of the date of issuance. False information may invalidate a building permit and stop all work..</p>		<b>Special Zone or Reviews</b> <input type="checkbox"/> Shoreland <input type="checkbox"/> Wetland <input type="checkbox"/> Flood Zone <input type="checkbox"/> Subdivision <input type="checkbox"/> Site Plan Maj <input type="checkbox"/> Minor <input type="checkbox"/> MM <input type="checkbox"/> Date: <i>11/03/05 Jm</i>	<b>Zoning Appeal</b> <input type="checkbox"/> Variance <input type="checkbox"/> Miscellaneous <input type="checkbox"/> Conditional Use <input type="checkbox"/> Interpretation <input type="checkbox"/> Approved <input type="checkbox"/> Denied Date:	<b>Historic Preservation</b> <input checked="" type="checkbox"/> Not in District or Landmark <input type="checkbox"/> Does Not Require Review <input type="checkbox"/> Requires Review <input type="checkbox"/> Approved <input type="checkbox"/> Approved w/Conditions <input type="checkbox"/> Denied Date: <i>11/3/05 Jm</i>
		OK		

**CERTIFICATION**

I hereby certify that I am the owner of record of the named property, or that the proposed work is authorized by the owner of record and that I have been authorized by the owner to make this application as his authorized agent and I agree to conform to all applicable laws of this jurisdiction. In addition, if a permit for work described in the application is issued, I certify that the code official's authorized representative shall have the authority to enter all areas covered by such permit at any reasonable hour to enforce the provision of the code(s) applicable to such permit.

SIGNATURE OF APPLICANT \_\_\_\_\_ ADDRESS \_\_\_\_\_ DATE \_\_\_\_\_ PHONE \_\_\_\_\_

RESPONSIBLE PERSON IN CHARGE OF WORK, TITLE \_\_\_\_\_ DATE \_\_\_\_\_ PHONE \_\_\_\_\_

**City of Portland, Maine - Building or Use Permit**

389 Congress Street, 04101 Tel: (207) 874-8703, Fax: (207) 874-8716

<b>Permit No:</b> 05-1550	<b>Date Applied For:</b> 10/21/2005	<b>CBL:</b> 069 A007001
------------------------------	--	----------------------------

<b>Location of Construction:</b> 22 CHADWICK ST	<b>Owner Name:</b> HIATT DAVID B & GWEN KEIG	<b>Owner Address:</b> 22 CHADWICK ST	<b>Phone:</b>
<b>Business Name:</b>	<b>Contractor Name:</b> Frost N Flame	<b>Contractor Address:</b> 629 Main St. Gorham	<b>Phone</b> (207) 856-7000
<b>Lessee/Buyer's Name</b>	<b>Phone:</b>	<b>Permit Type:</b> HVAC	

<b>Proposed Use:</b> Single Family Home/ Gas unit in fireplace	<b>Proposed Project Description:</b> Gas unit in fireplace
---	---

<b>Dept:</b> Zoning	<b>Status:</b> Approved	<b>Reviewer:</b> Tom Markley	<b>Approval Date:</b> 11/03/2005
<b>Note:</b>			<b>Ok to Issue:</b> <input type="checkbox"/>
<b>Dept:</b> Building	<b>Status:</b> Approved	<b>Reviewer:</b> Tom Markley	<b>Approval Date:</b> 11/03/2005
<b>Note:</b>			<b>Ok to Issue:</b> <input checked="" type="checkbox"/>
1) The installation must comply with the State of Maine Gas Regulations.			
<b>Dept:</b> Fire	<b>Status:</b> Approved with Conditions	<b>Reviewer:</b> Cptn Greg Cass	<b>Approval Date:</b> 10/24/2005
<b>Note:</b>			<b>Ok to Issue:</b> <input checked="" type="checkbox"/>
1) Install to NFPA 54			

**SEALED LAKE POOLS ROYAL IMPROVEMENTS, INC.**  
**FROST N' FLAME**

617-335-0117 **JOB INVOICE**

329 Main St.  
 Gorham, ME 04038  
 856-1000 856-7000  
 Fax 856-1104

889 Roosevelt Trail  
 N. Windham, ME 04062  
 893-3483 893-2876

HOME PHONE 891-0028	WORK PHONE 858-232-5968
CELL PHONE	ORDER TAKEN BY Justin Troy
DATE OF ORDER 10/8/05	CONTRACTOR
PHONE #	8750011
MAILING ADDRESS	

To: Customer David Hiett  
22 Chadwick Town: Portland  
 State: ME Zip Code: 04102

Directions: Take RT 25 all the way to Congress St at light go straight take 1st (L) Vaughn St. about 3 blocks up on (R) Carroll St. Take 1st (L) onto Chadwick down on (R) #22 number up high on house

Natural Gas		
1 fireplace woodburner insert 34 DVL # 98400106		1,692.00
1 Metropolitan Face Block # 98500514		223.00
1 ceramic brick insert # 39500638		112.00
1 Custom Summit Steel Fireplace Thompson Anderson 1/4 31 x 42 extra 1/4 3" riser base	198	245.00
2- Flex Retin up chimney 25 FT (Paint/Up Cap Block)		645.00
<b>TOTAL MATERIALS:</b>		<b>2917.00</b>

<p>Connect to existing gas line on other side of wall</p>	
COST OF ANY PROPANE NGI INCLUDED	
Run gas line out thru side of fireplace on (R) then into cabinet area go towards other side of wall there is gas line stubbed there already	
GAS LINE MATERIALS	75.00
GAS LINE LABOR	65.00
REGULATOR & GAS TANK PROPERTY OF WISNER ENERGY	
Install insert & vent	575.00
PERMIT FEE IF REQUIRED	
ADDITIONAL SHIPPING COST	
JOB LABOR	575.00
MATERIALS	2917.00
MATERIALS FOR GAS LINE	75.00
GAS LINE LABOR	65.00
TAX	149.60
<b>TOTAL</b>	<b>3781.60</b>
- SITE INSPECTION	- 25.00
<b>BALANCE DUE</b>	<b>3756.60</b>

20% Restocking Fee for ANY returned or cancelled materials!

I, the customer, have read the back of contract for terms & conditions of sale, and has signed back page

Work ordered by \_\_\_\_\_  
 Signature \_\_\_\_\_

I hereby acknowledge the satisfactory completion of the above described work

**ANY PERMITS REQUIRED ARE CUSTOMER'S RESPONSIBILITY**

50% DEPOSIT TO ORDER: 1878.30  
 BALANCE DUE UPON INSTALLATION: 1878.30

**Thank You**

# **Travis Industries, Inc.**

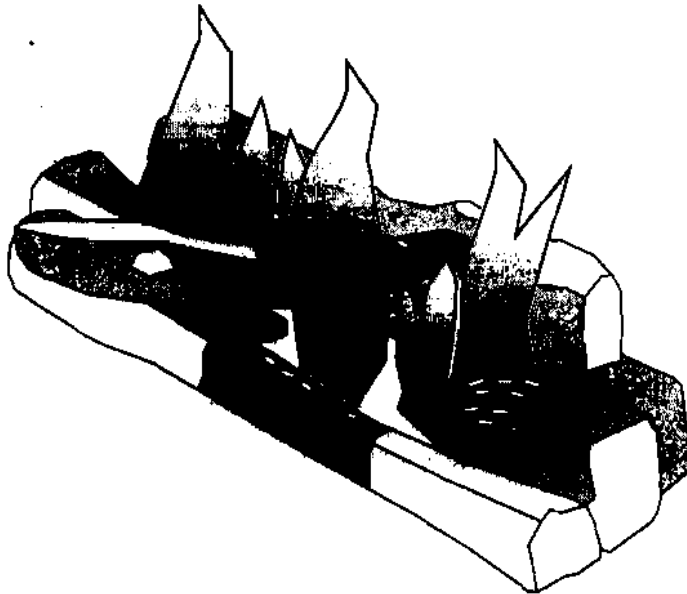

Featuring the



Burner

- Direct Vent Fireplace Insert
- Masonry or Factory Built (Metal) Fireplace
- Residential or Mobile Home



Listed

ANSI Z21.88 CSA 2.33 M68  
CAN/CGA 2.17 M61, LUL 307b

**WARNING:** Improper installation, adjustment, alteration, service or maintenance can cause injury or property damage. Refer to this manual. For assistance or additional information consult a qualified installer, service agency, or the gas supplier.

- Do not store or use gasoline or other flammable vapors and liquids in the vicinity of this or any other appliance.
- Installation must be performed by a qualified installer, service agency or the gas supplier

#### **IF YOU SMELL GAS**

- Do not try to light any appliance.
- Do not touch any electrical switch; do not use any phone in your building.
- Immediately call gas supplier from a neighbor's phone. Follow the gas supplier's instructions.
- If you cannot reach your gas supplier, call the fire department.

## **DVL Insert EF Owner's Manual**

**Installer:** After installation give this manual to the homeowner and explain operation of this fireplace.

\$10.00

© Copyright 2003, T.I.

Part # 100-01151

4030207



**Travis Industries, Inc.**

10850 117th Place N.E. Kirkland, WA 98033

## Insert Placement

- Insert must be placed within a code-conforming masonry fireplace or tested and listed zero-clearance (metal) fireplace. Fix any fireplace damage prior to installation.
- Because the insert uses a circulation blower, clean the fireplace, smoke shelf, and chimney prior to installation. We recommend painting the interior surface of the fireplace with latex paint to further eliminate dust.
- This heater may be placed in a bedroom. Please be aware of the large amount of heat this appliance produces when determining a location.

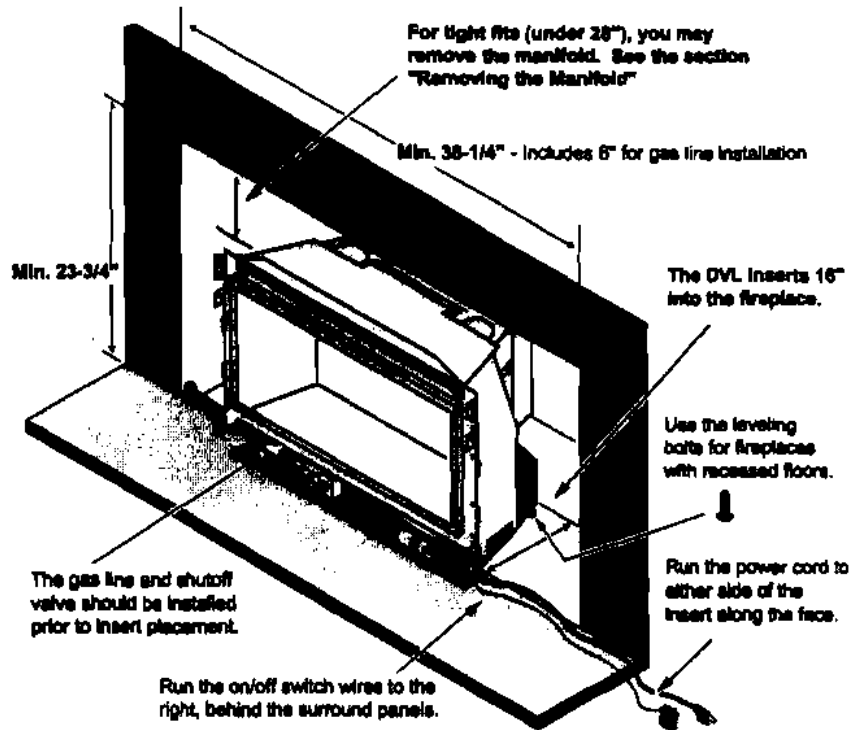

## Zero-Clearance (Metal) Fireplace Requirements:

- The damper ("A") and grata (with log set) ("B") must be removed (see the illustration below)
  - The smoke shelf ("C"), internal baffles ("D"), screen ("E"), masonry lining or refractory ("G" & "I"), and metal or glass doors ("F") may be removed (if applicable)
- NOTE:** If any internal baffle is cut, bent, or removed, the fireplace must be permanently marked to indicate that it has been altered and is no longer suitable for burning solid fuel (wood).
- The insulation ("H"), and any structured rigid frame members (metal sides, floor, door frame, face of the fireplace, etc.) must not be removed or altered.

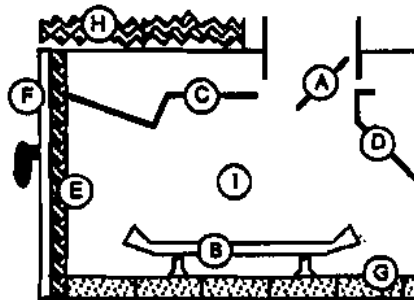

## Hearth Requirements

- The heater must be installed on a non-combustible hearth extending a minimum 12" from the fireplace opening (local codes may require a larger hearth). The hearth must also extend to both sides of the face (see page 9 for face sizing).

## Insert Clearances

- No combustibles may be within, or swing within, 36" of the front of the insert (drapes, doors)

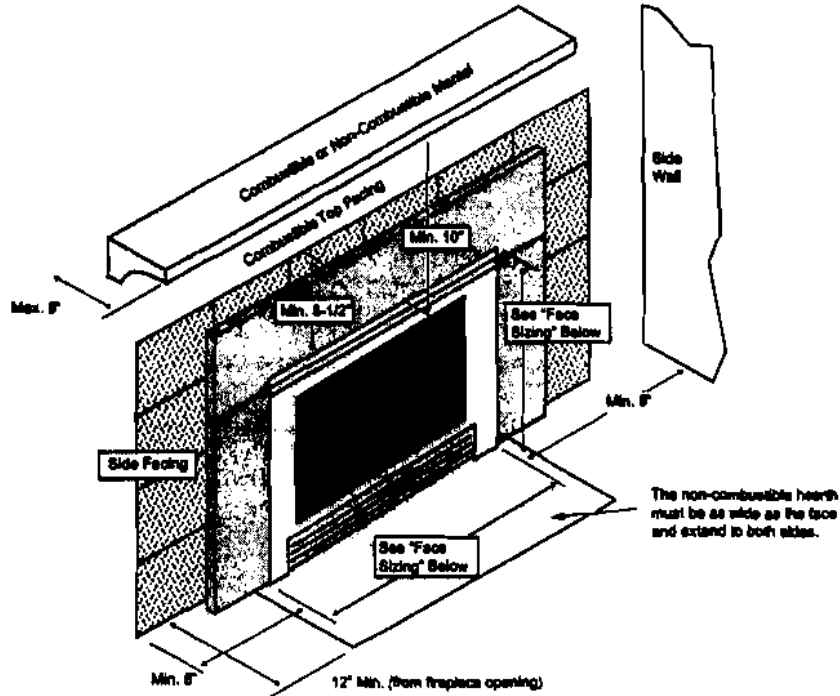

## Mantel Clearances

The mantel must be a minimum 10" above the face and a maximum 8" deep.

NOTE: The combustible area above the facing must not protrude more than 3/4" from the facing. If it does, it is considered a mantel and must meet the mantel requirements listed in this manual.

## Face Sizing

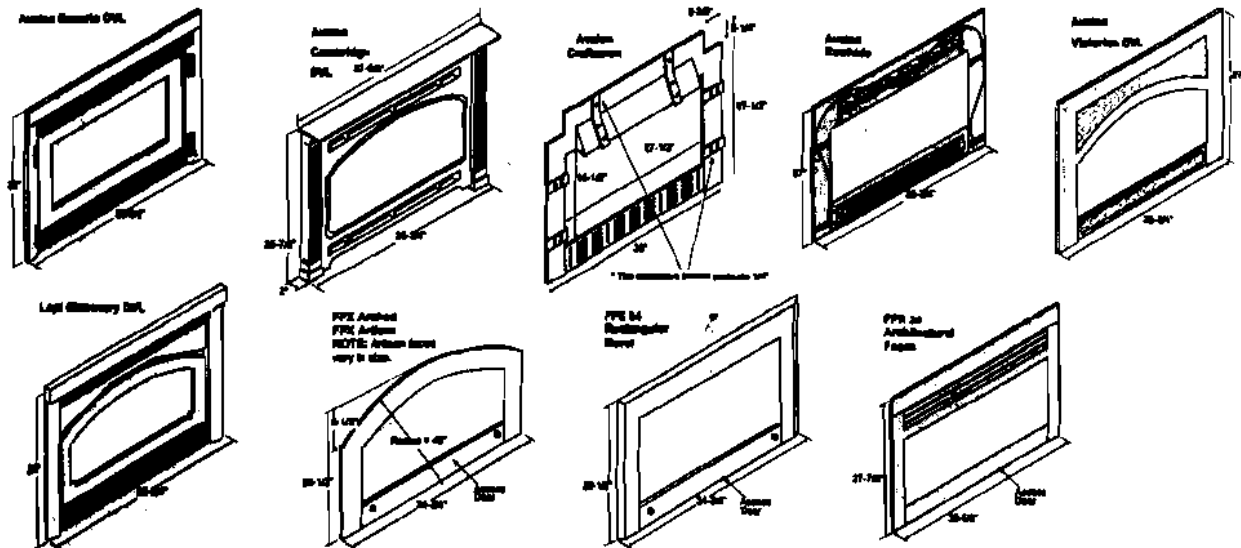

## Vent Requirements

- I The gas appliance and vent system must be vented directly to the outside of the building, and never be attached to a chimney serving a separate solid fuel or gas-burning appliance. Each direct vent gas appliance must use its own separate vent system.
- I Make sure the exhaust pipe on the heater connects to the exhaust portion of the cap. The illustrations below show how the flex liners should be attached.
- The exhaust vent must reline the entire length of the chimney and terminate above the chimney top
- I Be careful not to crimp or rupture the liner when bending it into chimney offsets
- When installed, the vent must meet all of the vent manufacturer's requirements
- Make sure to order the following:
  - 4" UL 441 Gas Liner for Exhaust, 3" UL 441 Gas Liner for Air Inlet
  - 6-5/8" to 3" & 4" Co-Linear Adapter & Flashing (Travis Part # 98900124).
  - Vertical Termination Cap (Dura-Vent pt # 991)

## Altitude Considerations

This heater has been tested at altitudes ranging from sea level to 8,000 feet (2,400 M). In this testing we have found that the heater, with its standard orifice, burns correctly with just an air shutter adjustment. If local codes require resizing the orifice, in the U.S.A. refer to ANSI Z23.1, Appendix P, in Canada B-149.1 or B-149.2

- I Failure to adjust the air shutter properly may lead to improper combustion which can create a safety hazard. Consult your dealer or installer if you suspect an improperly adjusted air shutter.

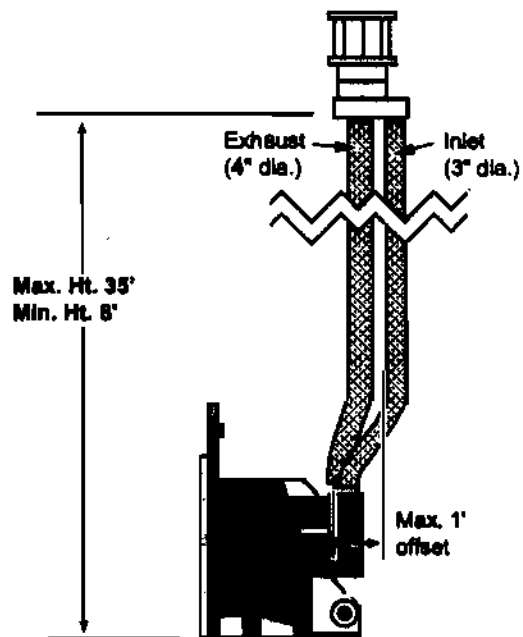

## Vent Restrictor

**WARNING:** Restrictor adjustment should only be done by a qualified installer.

Only those installations determined to be over-drafting require this adjustment. The best indication of over-drafting is a hyper-active flame pattern (flames that move too quickly). If the air shutter is constricted, the flames become short and yellow, yet still very active. Over-drafting may affect the pilot, but this is not the best way to determine over-drafting. Over-drafting is most likely in tall venting configurations (especially if using an "Exhaust Only Re-Line"). Do not over-restrict the vent (this leads to ghosting or lifting flames - reduce restrictor setting).

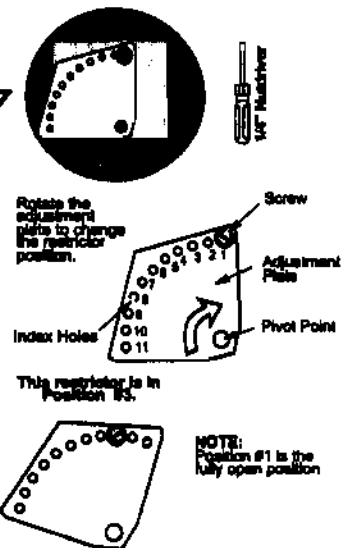
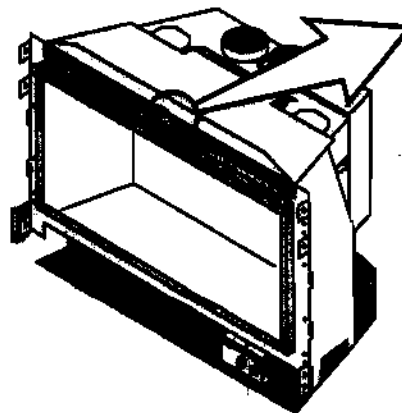

To Adjust the Restrictor:

- 1 Determine a restrictor position. Start low (move the restrictor a maximum two positions at a time) and thoroughly test the heater before adjusting further.
- 2 Remove the screw with a 1/4" nutdriver (or screwdriver).
- 3 Rotate the adjustment plate clockwise until the correct index hole is below the pivot point. Insert the screw into the correct index hole and tighten.

## Vent Installation

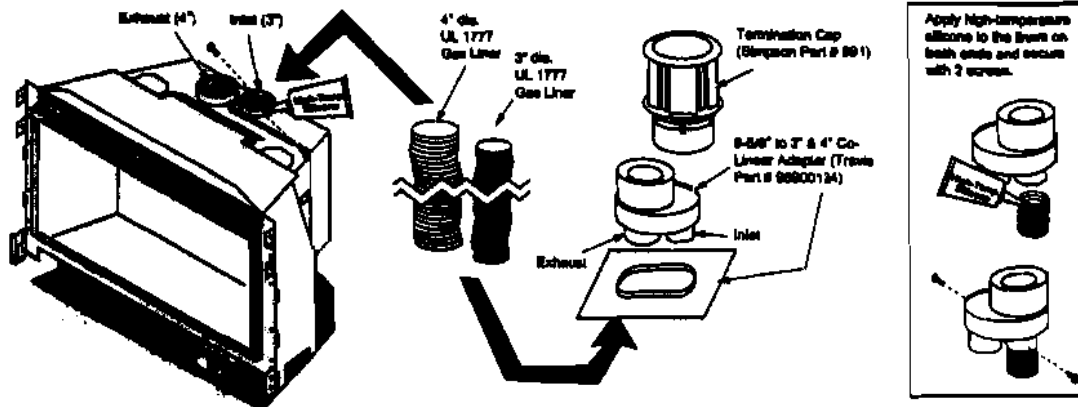

## Vent Location

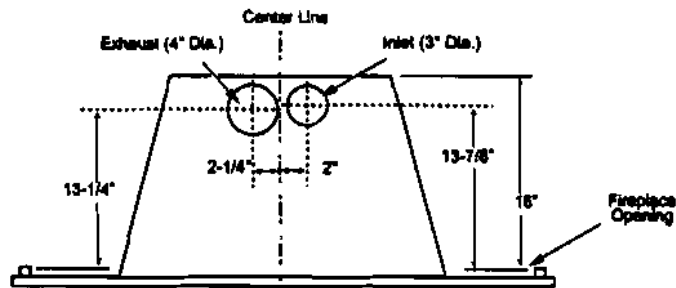

## Vent Configurations

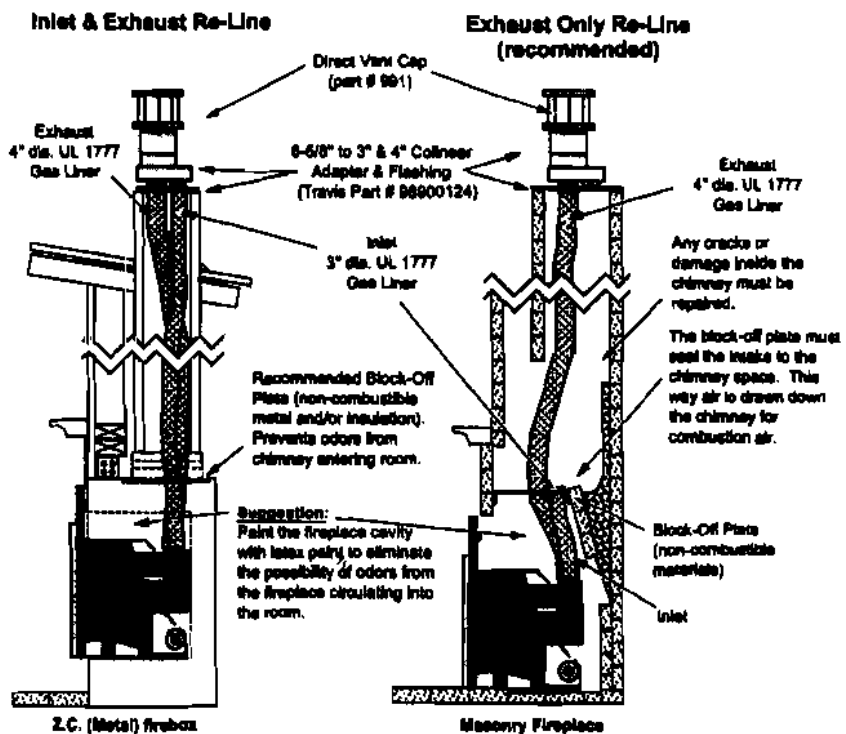

NOTE: You may use either re-line configuration with a masonry or zero-clearance fireplace.





# CITY OF PORTLAND, MAINE

Department of Building Inspections

Dec 01 2005

Project from Frank A. Stone  
Location of Work 99 Church

Cost of Construction \$ \_\_\_\_\_  
Permit Fee \_\_\_\_\_  
Plumbing (15) \_\_\_\_\_ Electrical (22) \_\_\_\_\_ Site Plan (22) \_\_\_\_\_

169 A009  
111 511 Total Collected \$ 5260

## THIS IS NOT A PERMIT

This work is to be started until PERMIT CARD is actually posted. No work shall be done until the permit is posted. Acceptance of fee is no guarantee that permit will be issued. PRESERVE THIS RECEIPT. In case permit cannot be issued the amount of the fee will be refunded upon return of the receipt less \$10.00 or 10% whichever is greater.

NOTE - Applicant's Copy  
OWNER - Office Copy  
Permit Copy

This page contains a detailed description of the Parcel ID you selected. Press the **New Search** button at the bottom of the screen to submit a new query.

**Current Owner Information**

<b>Card Number</b>	1 of 1
<b>Parcel ID</b>	069 A007001
<b>Location</b>	22 CHADWICK ST
<b>Land Use</b>	SINGLE FAMILY
<b>Owner Address</b>	HIATT DAVID B & GWEN KEIGHLEY 22 CHADWICK ST PORTLAND ME 04102
<b>Book/Page</b>	16604/246
<b>Legal</b>	69-A-7 CHADWICK ST 20-24  10938 SF

**Current Assessed Valuation For Fiscal Year 2006**

<b>Land</b>	<b>Building</b>	<b>Total</b>
\$206,320	\$348,890	\$555,210

**Estimated Assessed Valuation For Fiscal Year 2007\***

<b>Land</b>	<b>Building</b>	<b>Total</b>
\$304,700	\$448,600	\$753,300

\* Value subject to change based upon review of property status as of 4/1/06.  
The tax rate will be determined by City Council in May 2006.

**Property Information**

<b>Year Built</b> 1928	<b>Style</b> Mansion	<b>Story Height</b> 2	<b>Sq. Ft.</b> 3736	<b>Total Acres</b> 0.251	
<b>Bedrooms</b> 4	<b>Full Baths</b> 3	<b>Half Baths</b>	<b>Total Rooms</b> 8	<b>Attic</b> Unfin	<b>Basement</b> Full

**Outbuildings**

<b>Type</b>	<b>Quantity</b>	<b>Year Built</b>	<b>Size</b>	<b>Grade</b>	<b>Condition</b>
-------------	-----------------	-------------------	-------------	--------------	------------------

**Sales Information**

<b>Date</b> 08/06/2001	<b>Type</b> LAND + BLDING	<b>Price</b> \$721,000	<b>Book/Page</b> 16604-246
---------------------------	------------------------------	---------------------------	-------------------------------

**Picture and Sketch**

[Picture](#)      [Sketch](#)      [Tax Map](#)

[Click here to view Tax Roll Information.](#)

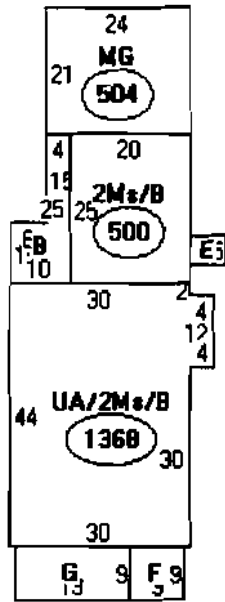

Descriptor/Area

- A: UA/2Ms/B  
1368 sqft
- B: OFP  
160 sqft
- C: 2Ms/B  
500 sqft
- D: MG  
504 sqft
- E: MUB  
30 sqft
- F: OF  
81 sqft
- G: EP  
171 sqft