

BILL OF MATERIALS

| ITEM | QTY. | DESCRIPTION | DRAWING NO | WT. # |
|------|------|----------------------|------------|-------|
| 1 | 2 | C4 X 4.5# @ 104" LG. | | 40.17 |
| | | TOTAL WEIGHT | | 80.34 |

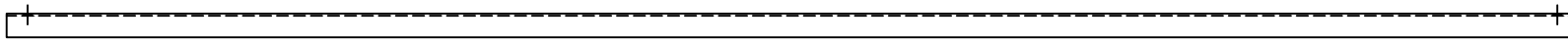

TOP VIEW

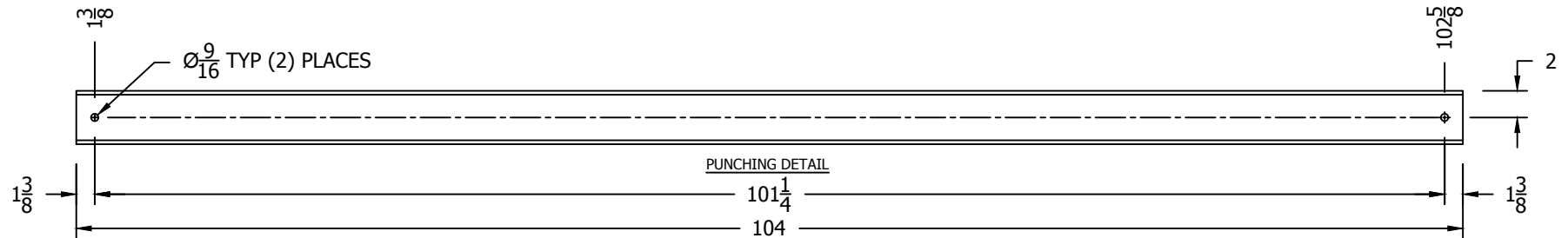
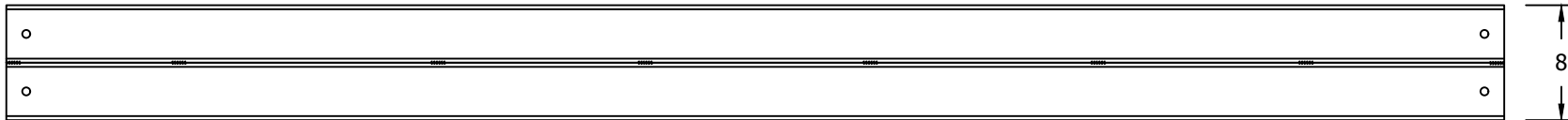

FRONT VIEW

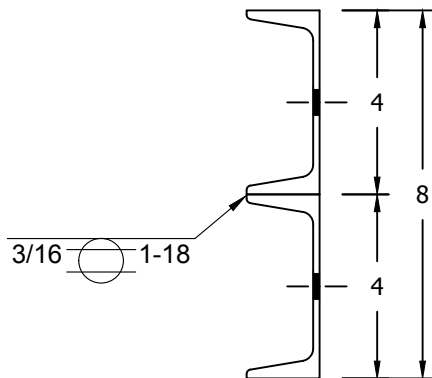

The information contained in this drawing is considered proprietary to Elite Storage Solutions, LLC. Permission of the drawing is not a license to distribute this information to any other party without prior written permission of Elite Storage Solutions, LLC. The inclusion of non-proprietary information (ie. Building dimensions or other facilities) shall not be considered as cause for disavowing this statement. The sole purpose of this drawing is informational for the customer.

STANDARD TOLERANCES

| | | |
|----------|-----|-------|
| FEET | +/- | 1/8" |
| INCHES | +/- | 1/32" |
| DECIMALS | +/- | .001 |
| ANGLES | +/- | 1.0° |

| | | | |
|--------------------|--------------|--|--|
| FOR: | DESCRIPTION: | GUARD RAIL SLAT DOUBLE C4 X 4.5# CHANNELS | |
| SCALE: 1-1/2" = 1' | | FILE NAME: X-S-GSLT-104.00.dwg | |
| DRAWN BY: MDH | | DRAWING NO. | |
| DATE: 10/8/15 | | X-S-GSLT-104.00 | |
| CHK BY: | | REV. # | |



1118 W. SPRING STREET MONROE, GA 30655

| REV. | DATE | BY | DESCRIPTION |
|------|------------------------|----|----------------------|
| | 10/19/2016 11:56:42 AM | | REVISION INFORMATION |