

**TYPICAL BEAM BEARING  
DETAIL**

1" = 1'-0" (S-1A)

**NOTE:**  
PAINT EXPOSED SURFACES  
OF W10 EXCEPT BOTTOM  
SURFACE OF BOTTOM FLANGE  
(COLOR = SAFETY YELLOW)

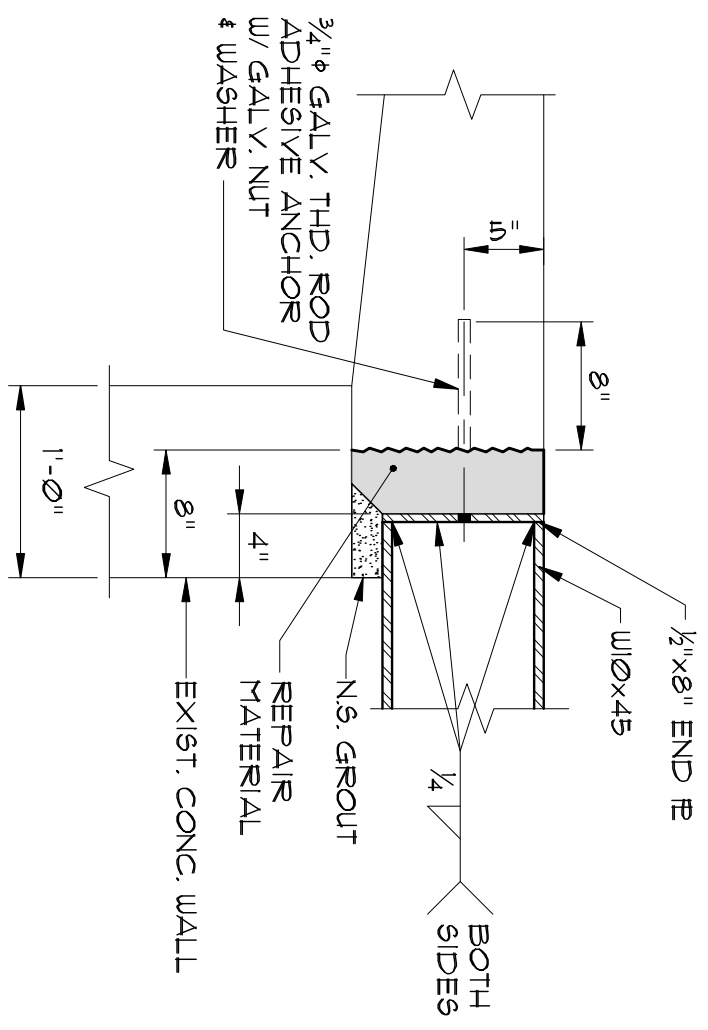

**SECTION**

1" = 1'-0" (S-3A)

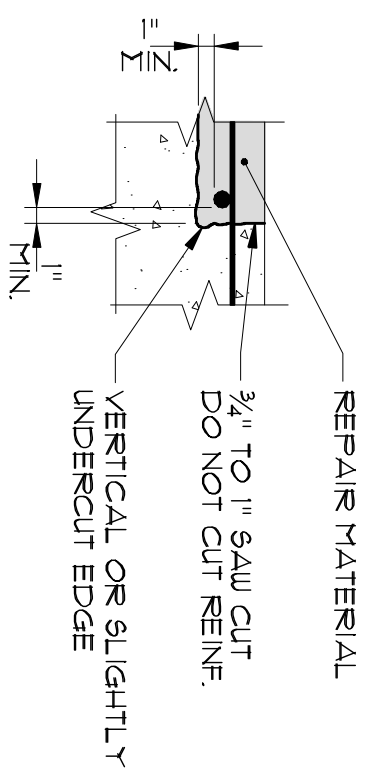

**EDGE DETAIL AT SPALL REPAIR**

N.T.S.

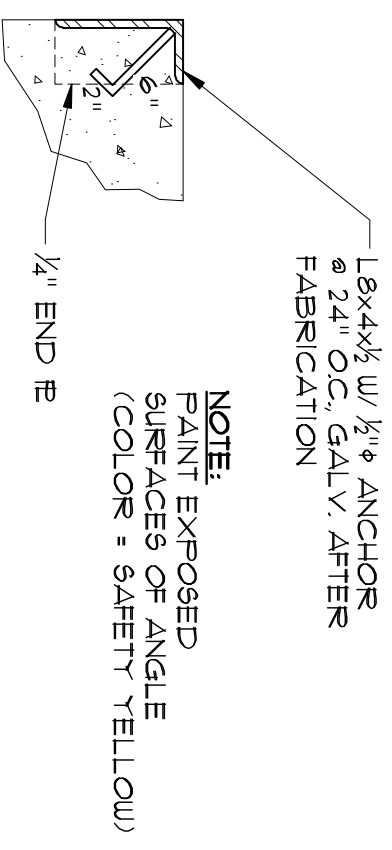

**PERIMETER ANGLE DETAIL**

N.T.S.

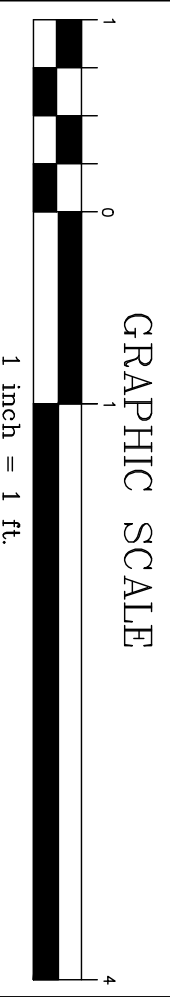

GRAPHIC SCALE

1 inch = 1 ft.

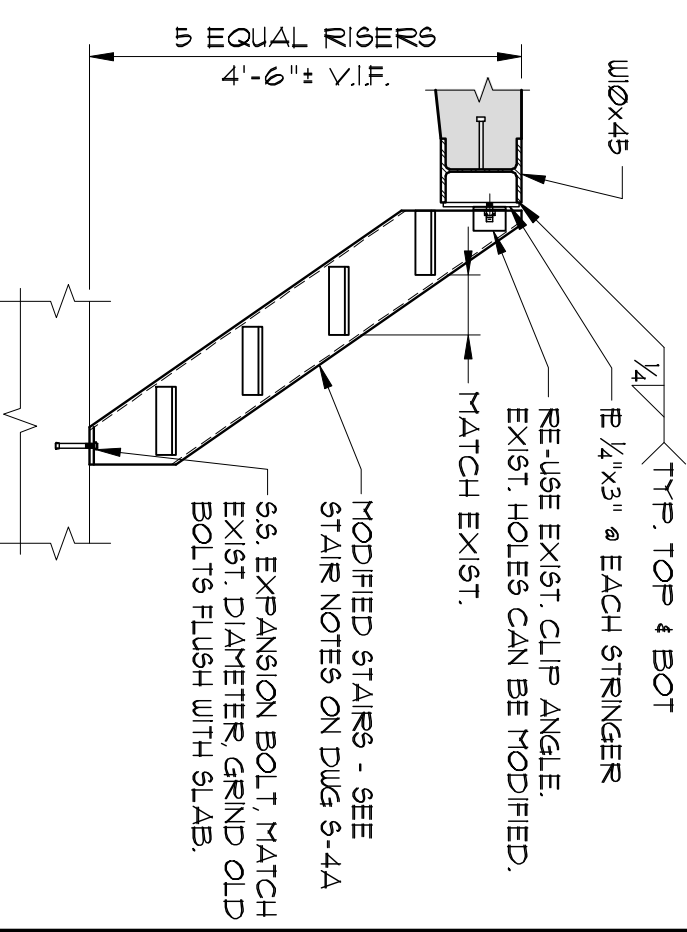

**STEEL STAIR DETAIL**

N.T.S.

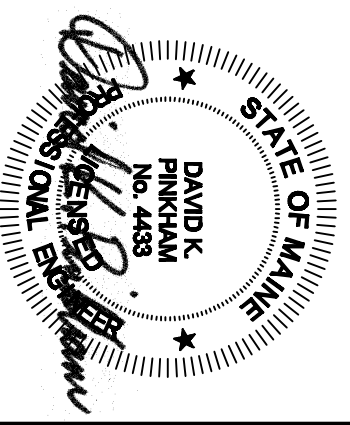

REVISED FOR BUILDING PERMIT JUNE 20, 2013

06-03-13

GREATER PORTLAND TRANSIT DISTRICT  
INSPECTION PIT SLAB REPAIR PROJECT  
PORTLAND, MAINE

SCALE: NONE  
DATE: JUNE 3, 2013  
DESIGNED BY: DKP  
PROJECT: 12330-P

S-3A  
SHEET 3 OF 4

PINKHAM & GREER CONSULTING ENGINEERS 28 VANNAH AVENUE, PORTLAND, MAINE TELEPHONE: (207) 781-5242