

**TRAP PRIMER CONNECTION DETAIL**  
NTS

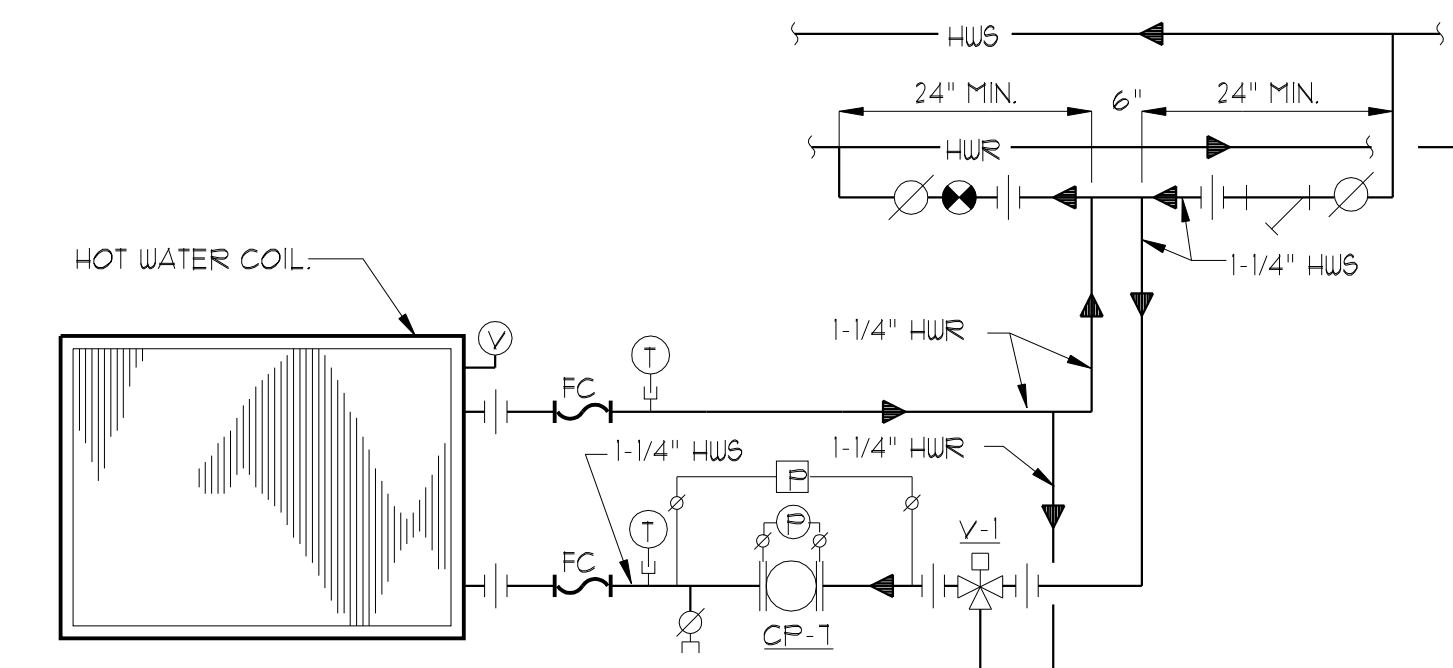

**SECONDARY PUMPING HEATING COIL PIPING SCHEMATIC WITH 3-WAY VALVE CONTROL (ERV-1)**  
NTS

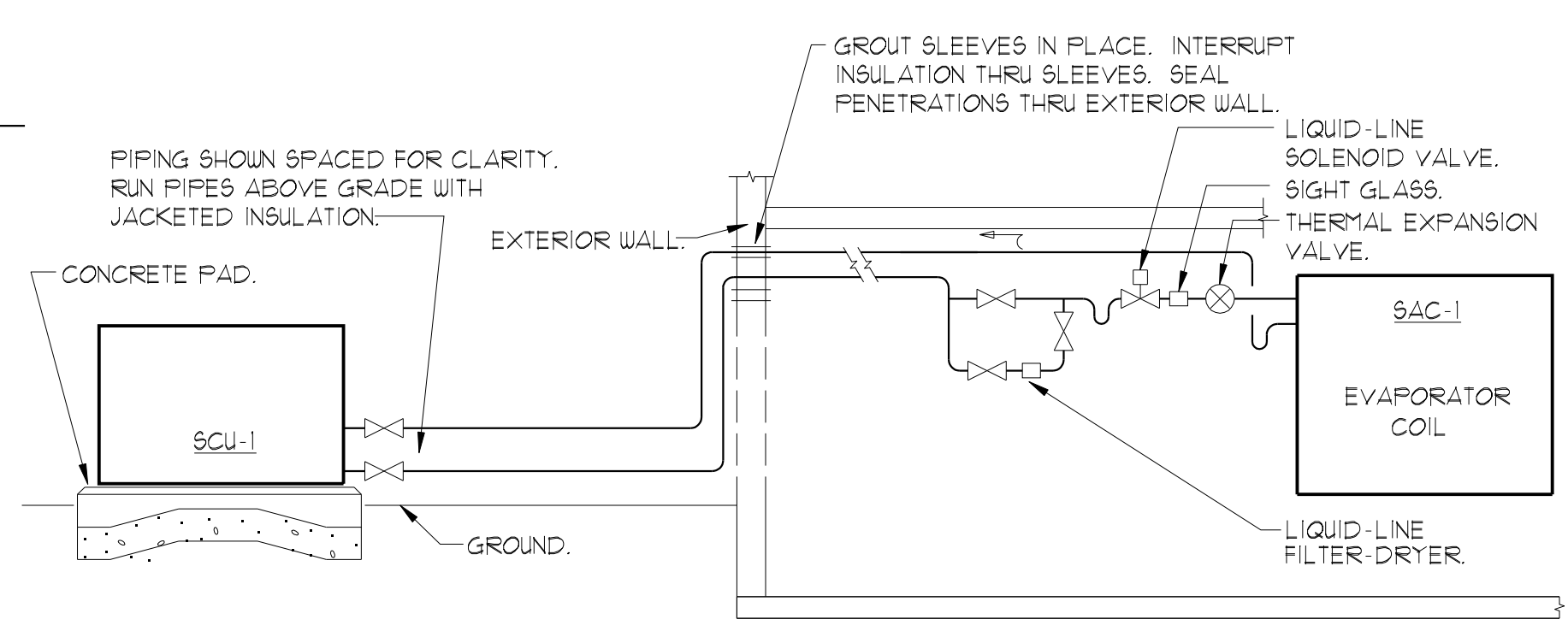

**REFRIGERANT PIPING DETAIL**  
NTS

**MECHANICAL & PLUMBING LEGEND**

NOTE USE SYMBOLS AND ABBREVIATIONS AS APPLICABLE FOR THIS MECHANICAL DRAWING SET. SOME SYMBOLS AND ABBREVIATIONS IN THIS LEGEND MAY NOT APPLY.

SYMBOL	DESCRIPTION	SYMBOL	DESCRIPTION	ABBREVIATION	DESCRIPTION	ABBREVIATION	DESCRIPTION	ABBREVIATION	DESCRIPTION
CA	COMPRESSED AIR PIPING (CA)	FC	FLEXIBLE PIPE CONNECTION (FC)	AAV	AUTOMATIC AIR VENT	EXH	EXHAUST	PENETN	PENETRATION
C	CONDENSATE DRAIN PIPING (C)	FC	FLEXIBLE PIPE CONNECTION (FC)	AD	ACCESS DOOR	FCO	FLOOR CLEANOUT	FF-*	FADDLE FAN TAG
CTR	COOLING TOWER RETURN PIPING (CTR)	FC	FLEXIBLE PIPE CONNECTION (FC)	AF	ABOVE FINISHED FLOOR	FD	FIRE DAMPER	FSIA	POUNDS PER SQUARE INCH ABSOLUTE
CTS	COOLING TOWER SUPPLY PIPING (CTS)	FC	FLEXIBLE PIPE CONNECTION (FC)	AHU-*	AIR HANDLING UNIT TAG	FD-*	FLOOR DRAIN TAG	FSIG	POUNDS PER SQUARE INCH GAGE
CUR	CHILLED WATER RETURN PIPING (CUR)	FC	FLEXIBLE PIPE CONNECTION (FC)	AMS	AIRFLOW MONITORING STATION	FLA	FULL LOAD AMPS	PVC	POLYVINYL CHLORIDE (PIPE)
CWS	CHILLED WATER SUPPLY PIPING (CWS)	FC	FLEXIBLE PIPE CONNECTION (FC)	AMP	AMPERES	FOR	FUEL OIL RETURN	RA	RETURN AIR
FOR	FUEL OIL RETURN PIPING (FOR)	FC	FLEXIBLE PIPE CONNECTION (FC)	AP	ACCESS PANEL	FOS	FUEL OIL SUPPLY	RD	ROOF DRAIN
FOS	FUEL OIL SUPPLY PIPING (FOS)	FC	FLEXIBLE PIPE CONNECTION (FC)	APD	AIR PRESSURE DROP	FPHB	FROST PROOF HOSE BIBB	RDE	RECOMMENDED DUAL ELEMENT FUSE AMPS
G	GAS PIPING (G)	FC	FLEXIBLE PIPE CONNECTION (FC)	AS-*	AIR SEPARATOR TAG	FT	FEET PER MINUTE	RFM-*	RADIANT FLOOR MANIFOLD TAG
HWR	HOT WATER RETURN PIPING (HWR)	FC	FLEXIBLE PIPE CONNECTION (FC)	ATC	AUTOMATIC TEMPERATURE CONTROL	FT	FEET PER MINUTE	RG-*	RETURN GRILLE TAG
HWS	HOT WATER SUPPLY PIPING (HWS)	FC	FLEXIBLE PIPE CONNECTION (FC)	B-*	BOILER TAG	FTR-*	FINTUBE RADIATION TAG	RHW	RECIRCULATED HOT WATER
RL	REFRIGERANT LIQUID PIPING (RL)	FC	FLEXIBLE PIPE CONNECTION (FC)	BD-*	BYPASS DAMPER TAG	GA	GAGE	RLA	RUNNING LOAD AMPS
RG	REFRIGERANT GAS PIPING (RG)	FC	FLEXIBLE PIPE CONNECTION (FC)	BFP-*	BACKFLOW PREVENTER TAG	GAL	GALLONS	RPM	REVOLUTIONS PER MINUTE
T	THERMOSTAT WIRING	FC	FLEXIBLE PIPE CONNECTION (FC)	BHP	BRAKE HORSEPOWER	GFH-*	GAS FIRED WATER HEATER TAG	RPS	REVOLUTIONS PER SECOND
SAN	SANITARY PIPING BELOW FLOOR (SAN)	FC	FLEXIBLE PIPE CONNECTION (FC)	BTUH	BRITISH THERMAL UNITS PER HOUR	GPH	GALLONS PER HOUR	RPZ	REDUCED PRESSURE ZONE
SAN	SANITARY PIPING ABOVE FLOOR (SAN)	FC	FLEXIBLE PIPE CONNECTION (FC)	CB	COUNTER BALANCED DAMPER	GPM	GALLONS PER MINUTE	RR-*	RETURN REGISTER TAG
SAN	SANITARY VENT PIPING	FC	FLEXIBLE PIPE CONNECTION (FC)	CC-*	CHECK VALVE TAG	GPM	GALLONS PER MINUTE	RTU	ROOM TEMPERATURE SENSOR
RWL	RAINWATER LEADER ABOVE SLAB (RWL)	FC	FLEXIBLE PIPE CONNECTION (FC)	CFM	CUBIC FEET PER MINUTE	GUH-*	GAS UNIT HEATER TAG	RV	RELIEF VALVE
CW	COLD WATER PIPING (CW)	FC	FLEXIBLE PIPE CONNECTION (FC)	CHL-R-*	CHILLER TAG	HC-*	HEATING COIL TAG	RWL	RAINWATER LEADER
HW	HOT WATER PIPING (HW)	FC	FLEXIBLE PIPE CONNECTION (FC)	CO	CLEANOUT	HP	HORSEPOWER	SA	SUPPLY AIR
RHW	RECIRCULATED HOT WATER PIPING (RHW)	FC	FLEXIBLE PIPE CONNECTION (FC)	CONV-*	CONVECTOR TAG	HRV-*	HEAT RECOVERY VENTILATOR TAG	SAN	SANITARY (DRAIN & WASTE)
PIPE CAP	PIPE CAP	FC	FLEXIBLE PIPE CONNECTION (FC)	CUH-*	CABINET UNIT HEATER TAG	HW	HOT WATER	SD	SMOKE DAMPER
DIR	DIRECTION OF FLUID FLOW	FC	FLEXIBLE PIPE CONNECTION (FC)	CP-*	CIRCULATING PUMP TAG	HWS/R	HOT WATER SUPPLY AND RETURN	SEER	SEASONAL ENERGY EFFICIENCY RATIO
ELBOW UP	ELBOW UP	FC	FLEXIBLE PIPE CONNECTION (FC)	CRD	CEILING RADIATION DAMPER	I-B-R	INSTITUTE OF BOILER AND RADIATOR MANUFACTURERS	SF	SUPPLY FAN
ELBOW DOWN	ELBOW DOWN	FC	FLEXIBLE PIPE CONNECTION (FC)	CV	VALVE COEFFICIENT	IFWH-*	INDIRECT FIRED WATER HEATER TAG	SG-*	SUPPLY GRILLE TAG
TEE UP	PIPE TEE UP	FC	FLEXIBLE PIPE CONNECTION (FC)	CW	COLD WATER	IN	INCHES	SP	STATIC PRESSURE
TEE DOWN	PIPE TEE DOWN	FC	FLEXIBLE PIPE CONNECTION (FC)	CWS/R	CHILLED WATER SUPPLY AND RETURN	IV-*	INTAKE VENT TAG	SP-*	SUMP PUMP TAG
REDUCER	PIPE REDUCER	FC	FLEXIBLE PIPE CONNECTION (FC)	DB	DUCT W/MANUAL DAMPER	L-*	LOUVER TAG	SR-*	SUPPLY REGISTER TAG
GUIDE	PIPE WITH GUIDE	FC	FLEXIBLE PIPE CONNECTION (FC)	DC	DUCT W/FLEXIBLE CONNECTION (FC)	LAT	LEAVING AIR TEMPERATURE	SQFT	SQUARE FEET
ANCHOR	PIPE WITH ANCHOR	FC	FLEXIBLE PIPE CONNECTION (FC)	DCA	DUCT W/ACOUSTIC LINING	LB	LEAVING AIR TEMPERATURE	TEMP	TEMPERATURE
BUTTERFLY VALVE	BUTTERFLY VALVE	FC	FLEXIBLE PIPE CONNECTION (FC)	DC	DUCT W/SQUARE-TO-ROUND TRANSITION	LD-*	LINEAR DIFFUSER TAG	TCP	TEMPERATURE CONTROL PANEL
OS & Y GATE VALVE	OS & Y GATE VALVE	FC	FLEXIBLE PIPE CONNECTION (FC)	DEG F	DEGREES FAHRENHEIT	LF	LINEAR FOOT	TMV-*	THERMOSTATIC MIXING VALVE TAG
BACKFLOW PREVENTER (BFP)	BACKFLOW PREVENTER (BFP)	FC	FLEXIBLE PIPE CONNECTION (FC)	DIA	DIAMETER	LRA	LOCKED ROTOR AMPS	TSP	TOTAL STATIC PRESSURE
CHECK VALVE	CHECK VALVE	FC	FLEXIBLE PIPE CONNECTION (FC)	DIW	DOWN IN WALL	LWCO	LOW WATER CUTOUT	TYP	TYPICAL
BALANCING VALVE (ADJUSTABLE)	BALANCING VALVE (ADJUSTABLE)	FC	FLEXIBLE PIPE CONNECTION (FC)	EA	EXHAUST AIR	LWT	LEAVING WATER TEMPERATURE	UH-*	UNIT HEATER TAG
AUTOMATIC FLOW CONTROL VALVE	AUTOMATIC FLOW CONTROL VALVE	FC	FLEXIBLE PIPE CONNECTION (FC)	EAT	ENTERING AIR TEMPERATURE	MAX	MAXIMUM	VAV-*	VARIABLE AIR VOLUME BOX TAG
RELIEF VALVE (RV)	RELIEF VALVE (RV)	FC	FLEXIBLE PIPE CONNECTION (FC)	EDB	ENTERING DRY BULB	MBH	THOUSANDS OF BTU PER HOUR	VB	VACUUM BREAKER
BALL VALVE	BALL VALVE	FC	FLEXIBLE PIPE CONNECTION (FC)	EDC-*	ELECTRIC DUCT COIL TAG	MCA	MINIMUM CIRCUIT AMPACITY	VSD	VARIABLE SPEED DRIVE
3/4\"/>									

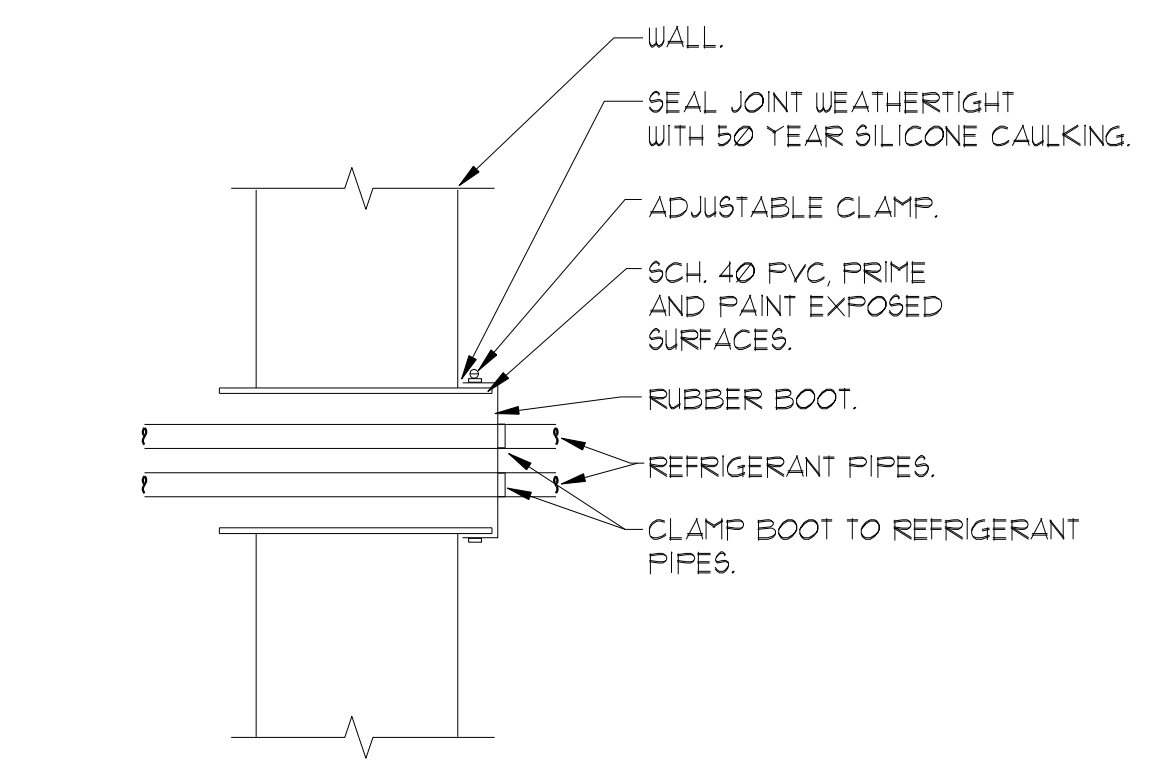

**REFRIGERANT PIPING AT WALL PENETRATION DETAIL**  
NTS

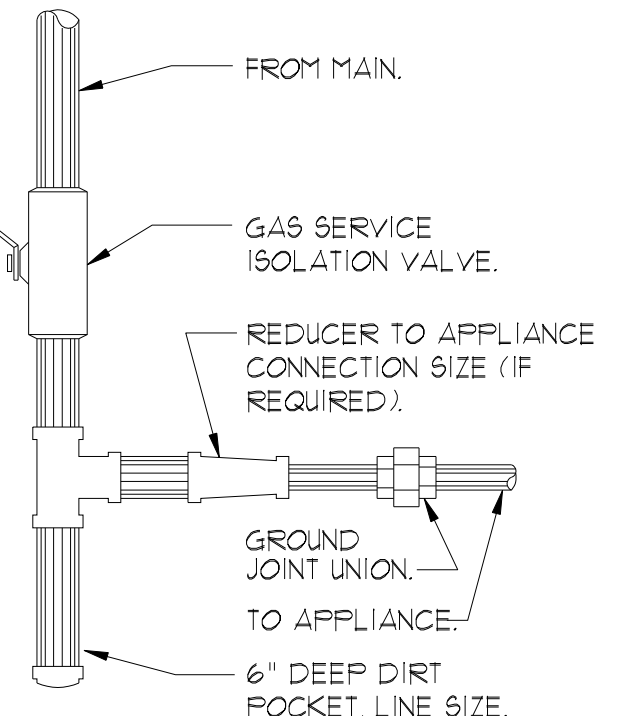

**DOWNFEED GAS PIPING CONNECTION DETAIL**  
NTS  
NOTE APPLIANCES WITH REGULATORS LOCATE PIPING SHOWN HEREIN UPSTREAM OF THE APPLIANCE REGULATOR. PROVIDE A TEST PLUG DOWNSTREAM OF THE APPLIANCE REGULATOR.

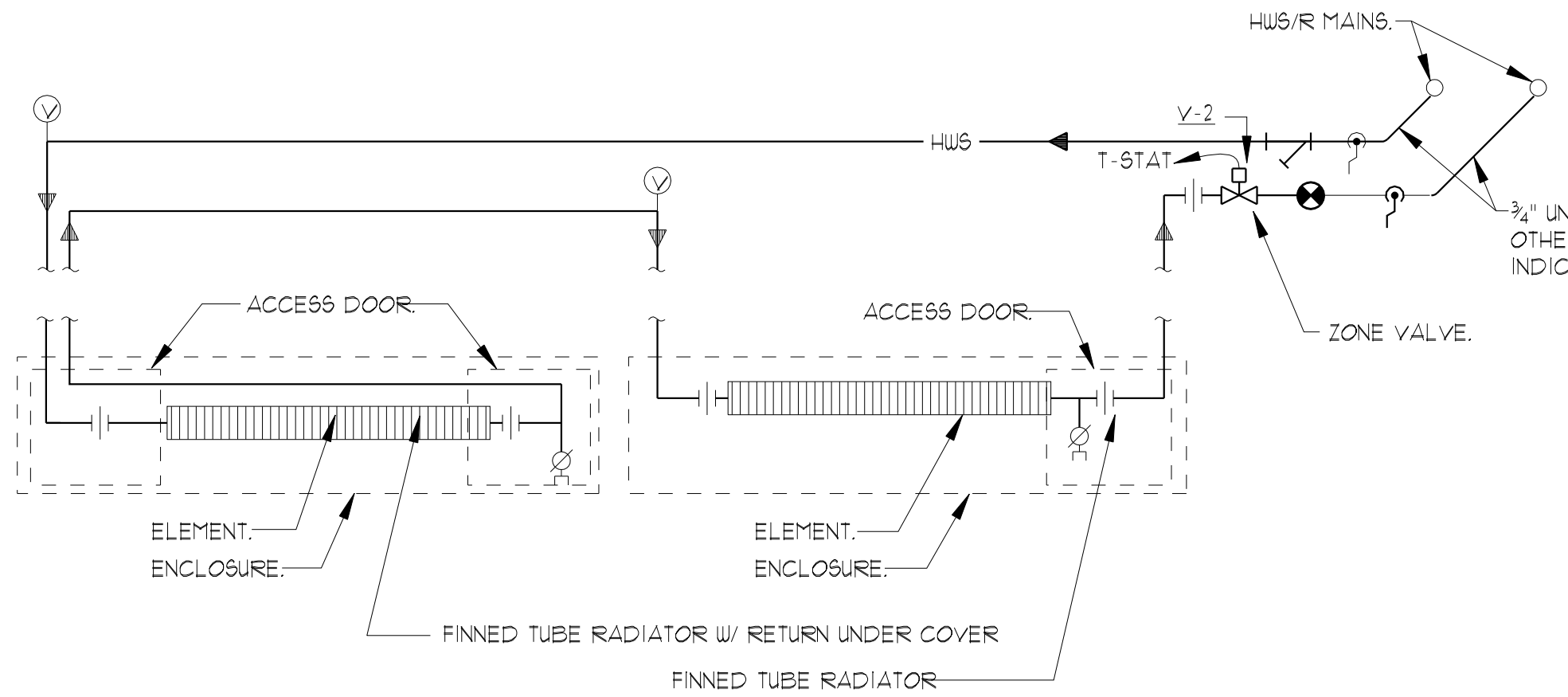

**DOWNFEED FIN TUBE WITH 2-WAY VALVE PIPING DETAIL**  
NTS

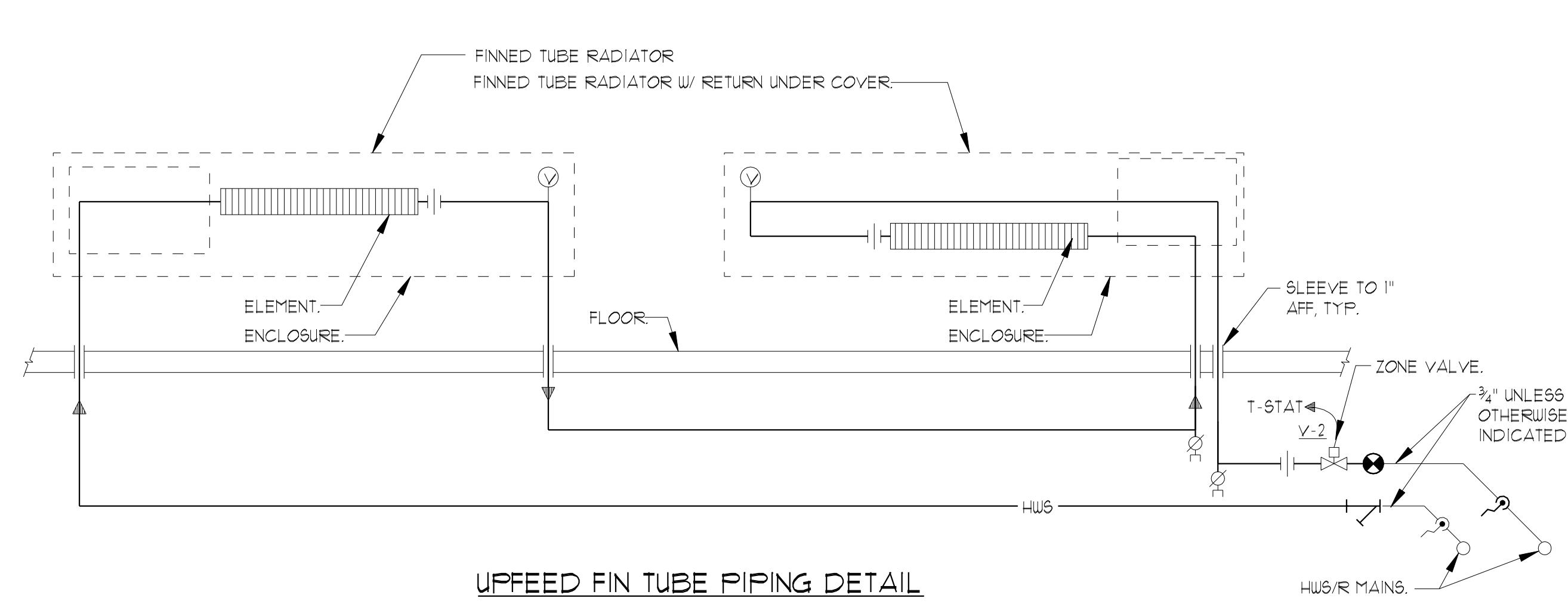

**UPFEED FIN TUBE PIPING DETAIL**  
NTS

**FORE RIVER APARTMENTS**

63 Frederic Street  
Portland, Maine

Project No: 04416 FRA

**MECHANICAL LEGEND AND DETAILS**

Scale: AS NOTED  
Date: 02/21/2005  
Revisions:

- △
- △
- △
- △
- △
- △
- △
- △

Drawing Number:  
**M3.2**