

# DISPLAY THIS CARD ON PRINCIPAL FRONTAGE OF WORK CITY OF PORTLAND

Please Read Application And Notes, If Any, Attached

## BUILDING INSPECTION PERMIT

Permit Number: 060237

PERMIT ISSUED  
MAR 20 2006  
CITY OF PORTLAND

This is to certify that VASILE JAMES J & PAUL M /Bailey Sign Company

has permission to Install new 23.5 sq ft sign

AT 1091 CONGRESS ST

067 B006001

provided that the person or persons who obtain or accept this permit shall comply with all of the provisions of the Statutes of the State and of the Ordinances of the City of Portland regulating the construction, maintenance and use of buildings and structures, and of the application on file in this department.

Apply to Public Works for street line and grade if nature of work requires such information.

Inspection of inspection must be...  
before this building or part thereof is occupied or to be occupied...  
YOUR NOTICE REQUIRED

A certificate of occupancy must be procured by owner before this building or part thereof is occupied.

### OTHER REQUIRED APPROVALS

Fire Dept. \_\_\_\_\_

Health Dept. \_\_\_\_\_

Appeal Board \_\_\_\_\_

Other \_\_\_\_\_

Department Name

*[Signature]*  
3/16/06  
Director - Building & Inspection Services

**PENALTY FOR REMOVING THIS CARD**

**PERMIT ISSUED**

**City of Portland, Maine - Building or Use Permit Application**  
389 Congress Street, 04101 Tel: (207) 874-8703, Fax: (207) 874-8716

Permit No: 06-0227 Issue Date: MAR 2 CBL: 067 3006001

Location of Construction: 1091 CONGRESS ST	Owner Name: VASILE JAMES J & PAULINE M	Owner Address: 34 VESPER ST	Phone:
Business Name:	Contractor Name: Bailey Sign Company Inc.	Contractor Address: 9 Thomas Drive Westbrook	Phone: 2077742843
Lessee/Buyer's Name	Phone:	Permit Type: Signs - Permanent	Zone: B2
Past Use: Commercial	Proposed Use: Commercial/ Denny's Restaurant/ Install new 23.5 sq ft sign	Permit Fee: \$76.00	Cost of Work: \$77.00
		CEO District: 3	
Proposed Project Description: Install new 23.5 sq ft sign		FIRE DEPT: <i>N/A</i> Signature: <i>[Signature]</i>	INSPECTION: Use Group: <i>U</i> Type: <i>Sign</i> <i>IBC 2003</i> Signature: <i>[Signature]</i>
		PEDESTRIAN ACTIVITIES DISTRICT (P.A.D.) Action: <input type="checkbox"/> Approved <input type="checkbox"/> Approved w/Conditions <input checked="" type="checkbox"/> Denied Signature: _____ Date: _____	

Permit Taken By: ldobson	Date Applied For: 02/22/2006	<b>Zoning Approval</b>		
<ol style="list-style-type: none"> <li>This permit application does not preclude the Applicant(s) from meeting applicable State and Federal Rules.</li> <li>Building permits do not include plumbing, septic or electrical work.</li> <li>Building permits are void if work is not started within six (6) months of the date of issuance. False information may invalidate a building permit and stop all work..</li> </ol>		<b>Special Zone or Reviews</b> <input type="checkbox"/> Shoreland <input type="checkbox"/> Wetland <input type="checkbox"/> Flood Zone <input type="checkbox"/> Subdivision <input type="checkbox"/> Site Plan Maj <input type="checkbox"/> Minor <input type="checkbox"/> MM <input type="checkbox"/> <i>cc</i> Date: <i>3/2/06</i> <i>AKM</i>	<b>Zoning Appeal</b> <input type="checkbox"/> Variance <input type="checkbox"/> Miscellaneous <input type="checkbox"/> Conditional Use <input type="checkbox"/> Interpretation <input type="checkbox"/> Approved <input type="checkbox"/> Denied Date: _____	<b>Historic Preservation</b> <input checked="" type="checkbox"/> Not in District or Landmark <input type="checkbox"/> Does Not Require Review <input type="checkbox"/> Requires Review <input type="checkbox"/> Approved <input type="checkbox"/> Approved w/Conditions <input type="checkbox"/> Denied <i>AKM</i> Date: _____

**CERTIFICATION**

I hereby certify that I am the owner of record of the named property, or that the proposed work is authorized by the owner of record and that I have been authorized by the owner to make this application as his authorized agent and I agree to conform to all applicable laws of this jurisdiction. In addition, if a permit for work described in the application is issued, I certify that the code official's authorized representative shall have the authority to enter all areas covered by such permit at any reasonable hour to enforce the provision of the code(s) applicable to such permit.

SIGNATURE OF APPLICANT	ADDRESS	DATE	PHONE
RESPONSIBLE PERSON IN CHARGE OF WORK, TITLE		DATE	PHONE

**City of Portland, Maine - Building or Use Permit**

389 Congress Street, 04101 Tel: (207) 874-8703, Fax: (207) 874-8716

Permit No: 06-0227	Date Applied For: 02/22/2006	CBL: 067 B006001
-----------------------	---------------------------------	---------------------

Location of Construction: 1091 CONGRESS ST	Owner Name: VASILE JAMES J & PAULINE M	Owner Address: 34 VESPER ST	Phone:
Business Name:	Contractor Name: Bailey Sign Company Inc.	Contractor Address: 9 Thomas Drive Westbrook	Phone: (207) 774-2843
Lessee/Buyer's Name	Phone:	Permit Type: Signs - Permanent	

Proposed Use: Commercial/ Denny's Restaurant/ Install new 23.5 sq ft sign	Proposed Project Description: Install new 23.5 sq ft sign
------------------------------------------------------------------------------	--------------------------------------------------------------

Dept: Zoning	Status: Approved	Reviewer: Ann Machado	Approval Date: 03/02/2006
Note: Existing signs: one pylon sign - 6' x 11' two building signs - 16" x 8'  New building sign - 8' x 4'			Ok to Issue: <input checked="" type="checkbox"/>
Dept: Building	Status: Approved with Conditions	Reviewer: Tammy Munson	Approval Date: 03/16/2006
Note: 1) Signage Installation to comply with Chapter 31 of the IBC 2003 building code.			Ok to Issue: <input checked="" type="checkbox"/>

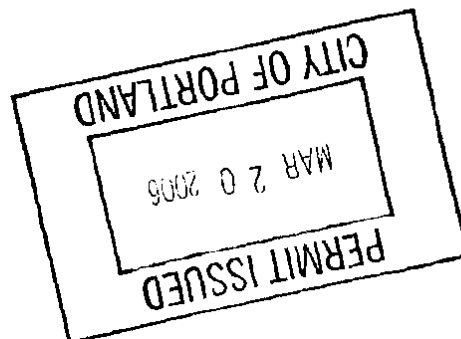



# Signage/Awning Permit Application

If you or the property owner owes real estate or personal property taxes or user charges on any property within the City, payment arrangements must be made before permits of any kind are accepted.

Location/Address of Construction: <u>1091-1107 Congress St.</u>		
Tax Assessor's Chart, Block & Lot Chart# <u>06567</u> Block# <u>B 6</u> Lot# <u>0</u>	Owner: <u>Bonnie Vasile Polli</u>	Telephone: <u>(607)926-1468</u>
Lessee/Buyer's Name (If Applicable) <u>Realty Resources Group</u>  <u>Contact: Kevin Labree</u>	Applicant name, address & telephone: <u>Bailey Sign, Inc.</u> <u>9 Thomas Dr.</u> <u>Westbrook, ME 04092</u> <u>774-2843</u>	Total s.f. of signage x \$2.00 Per s.f. plus \$30.00/\$65.00 For H.D. signage = Total Fee: \$ <u>112-</u> Awning Fee = cost of work <u>-</u> Total Fee: \$ <u>-</u>
Who should we contact when the permit is ready: <u>Deanna Emery</u> phone: <u>774-2843 ext. 115</u> <u>Bailey Sign, Inc</u>		
Tenant/allocated building space frontage (feet): Length: <u>60' x 20'</u> Height: <u>18'</u> Lot Frontage (feet) <u>52, 125 ft</u> Single Tenant or Multi Tenant Lot <u>single</u>		
Current Specific use: <u>Restaurant</u> If vacant, what was prior use: _____ Proposed Use: _____		
Information on proposed sign(s): Freestanding (e.g., pole) sign? Yes _____ No <input checked="" type="checkbox"/> Dimensions proposed: _____ Height from grade: _____ Bldg. wall sign? (attached to bldg) Yes <input checked="" type="checkbox"/> No _____ Dimensions proposed: <u>8' x 4'</u>		
Proposed awning? Yes _____ No <input checked="" type="checkbox"/> Is awning backlit? Yes _____ No _____ Height of awning: _____ Length of awning: _____ Depth: _____ Is there any communication, message, trademark or symbol on it? Yes _____ No _____ If yes, total s.f. of panels w/communications, message, trademark or symbol: _____ s.f.		
Information on existing and previously permitted sign(s): Freestanding (e.g., pole) sign? Yes <input checked="" type="checkbox"/> No _____ Dimensions proposed: <u>6' x 11'</u> Bldg. wall sign? (attached to bldg) Yes <input checked="" type="checkbox"/> No <input checked="" type="checkbox"/> Dimensions proposed: <u>2 sets = 16" x 8"</u> Awning? Yes _____ No <input checked="" type="checkbox"/> Sq. ft. area of awning w/communication: _____		
A site sketch and building sketch showing exactly where existing and new signage is located must be provided. Sketches and/or pictures of proposed signage and existing building are also required.		

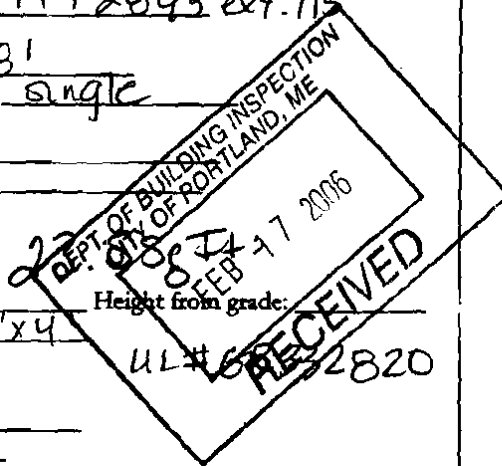

Please submit all of the information outlined in the Sign/Awning Application Checklist. Failure to do so may result in the automatic denial of your permit.

In order to be sure the City fully understands the full scope of the project, the Planning and Development Department may request additional information prior to the issuance of a permit. For further information visit us on-line at [www.portlandmaine.gov](http://www.portlandmaine.gov), stop by the Building Inspections office, room 315 City Hall or call 874-8703.

I hereby certify that I am the Owner of record of the named property, or that the owner of record authorizes the proposed work and that I have been authorized by the owner to make this application as his/her authorized agent. I agree to conform to all applicable laws of this jurisdiction. In addition, if a permit for work described in this application is issued, I certify that the Code Official's authorized representative shall have the authority to enter all areas covered by this permit at any reasonable hour to enforce the provisions of the codes applicable to this permit.

Signature of applicant: Deanna Emery | Bailey Sign, Inc. Date: 2/17/06

max cum. area 150 ft<sup>2</sup> This is not a permit; you may not commence ANY work until the permit is issued.  
60x2 = 120 ft<sup>2</sup> per facade. existing 1.33 x 8 = 10.64 ft<sup>2</sup> new 8'x4' = 32 ft<sup>2</sup>  
3 signs allowed along street + 1 10.64 ft<sup>2</sup> 21.28 OK.

Existing Signage







FEB/13/2006/MON 04:09 PM

P. 002

FROM :

FAX NO. : 6029261468

Jan. 27 2006 11:02AM P2

01/25/2006 18:28 FAX 807 7741183

Bailey Signs

02

WRITTEN CONSENT AND AGREEMENT relating to a certain sign proposed to be created on/a building located at 1091-1107 Congress St. in Portland, ME  
(Street Address) (City & State)

Bonnie Vasite Palli being the owner of the premises hereby  
(Property Owner)

gives consent to the creation of a certain sign by Bailey Signs, Inc. of Westbrook, ME. Over a public sidewalk or on a building from said premises as described in application to the Division of Inspection/Codes Services of Portland for permit to cover creation of said sign.  
(City of Permit Application)

And said consideration of the issuance of said permit Bonnie Vasite Palli  
(Property Owner)

owner of said premises, in event said sign shall cease to serve the purpose for which it was erected or shall become dangerous and in event the owner of said sign shall fail to remove said sign or make it permanently safe in case the sign still serves the purpose for which it was erected, hereby agrees for himself/herself or itself, for his/her heirs, its executors, and his/hers or its assigns, to completely remove said sign within ten (10) days of notice from said Inspector of Buildings that said sign is in such condition and order from him/her to remove it.

In witness whereof, the owner of said premises has signed this consent and agreement this

13<sup>th</sup> day of February, 2006  
(Day) (Month) (Year)

Bonnie Vasite Palli  
(Property Owner)

MARIE S. PALLI  
(Witness)



## Signage/Awning Permit Application Checklist

All of the following information is required and must be submitted. Checking off each item as you prepare your application package will ensure your package is complete and will help to expedite the permitting process.

- Certificate of Liability listing the City as additional insured if any portion of the sign abuts or encroaches on any public right of way, or can fall into any public right of way.
- Letter of permission from the owner indicating the permissions granted and the tenant/space building frontage.
- A sketch plan of lot indicating location of buildings, driveways and any abutting streets or rights of way, lengths of building frontages, street frontages and all existing setbacks. Please indicate on the plan all existing and proposed signs with their dimensions and specific locations. Be sure to include distance from the ground and building façade dimensions for any signage attached to the building.
- A sketch or photo of any proposed sign(s) indicating content, dimensions, materials, source of illumination, construction method as well as specifics of installation/attachment.
- Certificate of flammability required for awning or canopy.
- A UL# is required for lighted signs at the time of final inspection.
- Pre-application questionnaire completed and attached.
- Photos of existing signage
- Details for sign fastening, attachment or mounting in the ground.

Permit fee for signage or awning-with-signage: \$30.00 plus \$2.00 per square foot of sign.

Permit fee for awning-without-signage is based on cost of work:  
\$30.00 for the first \$1,000.00, \$9.00 per additional \$1,000.00 of cost.

Base application fee for any Historic District signage is \$65.00.





**CITY OF PORTLAND, MAINE**  
Department of Building Inspections

2-17 20 06

Received from Bailey Sign

Location of Work 1021 110th Congress St -

Cost of Construction \$ \_\_\_\_\_

Permit Fee \$ 77<sup>00</sup>

Building (IL)  Plumbing (I5) \_\_\_\_\_ Electrical (I2) \_\_\_\_\_ Site Plan (U2) \_\_\_\_\_

Other \_\_\_\_\_

CBL: 10519

Check #: 5479

Total Collected \$ 77<sup>00</sup>

**THIS IS NOT A PERMIT**

No work is to be started until PERMIT CARD is actually posted upon the premises. Acceptance of fee is no guarantee that permit will be granted. PRESERVE THIS RECEIPT. In case permit cannot be granted the amount of the fee will be refunded upon return of the receipt less \$10.00 or 10% whichever is greater.

WHITE - Applicant's Copy  
YELLOW - Office Copy  
PINK - Permit Copy

# DENNY'S 2000 SIGN SPECIFICATIONS - MODEL 2K-D-24-SF (SINGLE FACE WALL MOUNT)



**SPECIFICATIONS**  
 HELIARC WELDED ALUMINUM ANGLE FRAME W/ FABRICATED ALUMINUM CABINET & RETAINER. ACRYLIC POLYURETHANE FINISH PAN FORMED .118 SG-100 SOLAR GRADE LEXAN W/ 3M VINYL 2ND SURFACE (6) COLOR GRAPHIC APPLICATION UL APPROVED

- 1 **LETTER - RED**  
LACRYL LB-9145, SIGNTECH 3232, PMS 485
- 2 **DARK RED DROP SHADOW**  
SIGNTECH CC-294, PMS 1807
- 3 **OCHRE DROP SHADOW**  
SIGNTECH CC3-121, PMS 131
- 4 **YELLOW BKGD.**  
SIGNTECH 2037, PMS 116
- 5 **ORANGE BARS & BORDER**  
SIGNTECH CX3-126, PMS 138
- 6 **ORANGE CABINET**  
SW KEM 400 #F75BKXY5957-4311, PMS 138

CROSS SECTION - NO SCALE

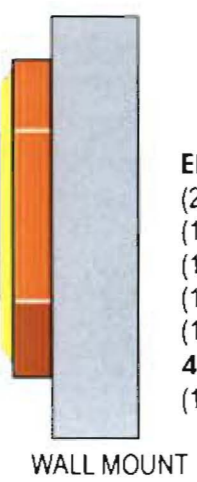
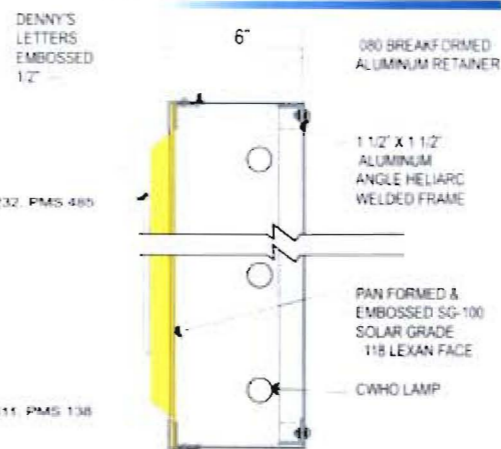

**ELECTRICAL**  
 (2) F84-T12/CWHO LAMPS  
 (1) F72-T12/CWHO LAMPS  
 (1) F36-T12/CWHO LAMPS  
 (1) ASB-0412-12 BALLAST  
 (1) ASB-0620-24 BALLAST  
**4.15 TOTAL AMPS**  
 (1) 15 AMP CIRCUIT REQUIRED

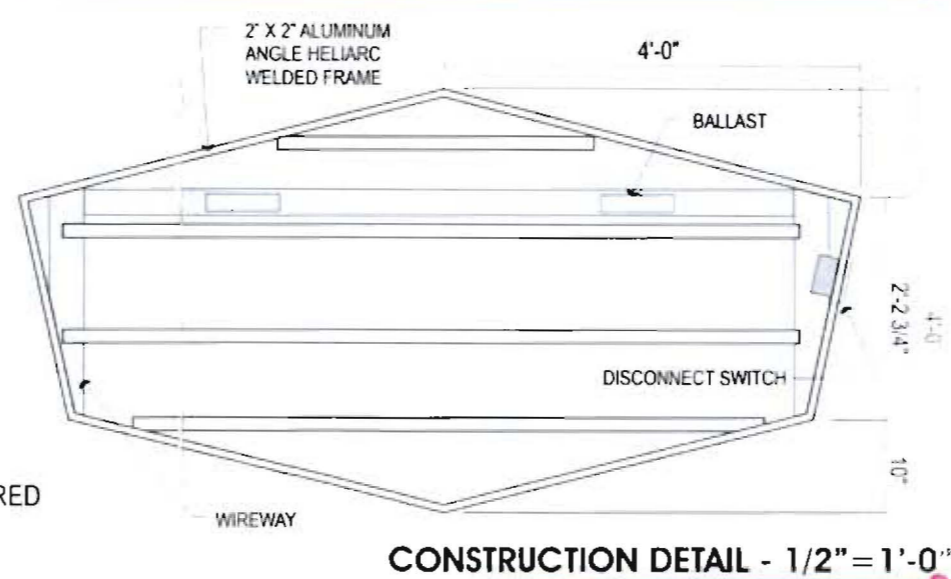

	<b>CUSTOMER:</b> Denny's <b>LOCATION / PROJECT:</b> Portland, ME <b>ADDRESS:</b> Congress Ave. <b>DATE:</b> 11.15.05	<b>DRAWING NO.:</b> DENNSB2.10.5 <b>DESIGNER:</b> St.Claire <b>ACCT. REP.:</b> DT <b>SCALE:</b> 1" = 1'-0"	<b>REVISION NO. / DATE:</b> 1 - wall sign replaced 10.27.05 2 - channel letters replaced 10.30.05	<b>CUSTOMER APPROVAL:</b>  <b>DATE:</b>
	Mail: P.O. Box 41156 Phoenix, AZ 85080-1156 Physical: 1101-A W. Melinda Ln Phoenix, AZ 85027 Ph: 623-792-3061 Fax 623-792-3063 North Carolina Office: 2693 Glen Forest Drive Winston-Salem, NC 27103 Ph: 336-774-7986 Fax: 425-977-7512			



# ITE PLAN

X = New sign on building

