

CONNECTION SCHEDULE						
BEAM	N	L	T	D	S	CAPACITY (KIP)
W8	2	6"	1/4"	1"	3"	16.3
W10	2	6"	1/4"	1 1/2"	3"	16.3
W12	3	9"	1/4"	1 1/2"	3"	25.6
W14	4	11 1/2"	3/8"	1 1/2"	3"	42.4
W16	4	12"	3/8"	1 1/2"	3"	42.4
W18	5	15"	3/8"	1 1/2"	3"	53.0
W21	6	18"	3/8"	1 1/2"	3"	63.6
W24	7	20 1/2"	3/8"	1 1/2"	3"	74.2

**NOTES:**

- BOLTS SHALL BE 3/4" DIA. A325N (U.N.O.)
- N = NUMBER OF BOLTS
- L = LENGTH OF PLATE
- T = THICKNESS OF PLATE
- D = DEPTH OF PLATE FROM TOP FLANGE OF BEAM
- S = BOLT SPACING
- SIMILAR AT CHANNEL SECTIONS OF SAME DEPTH

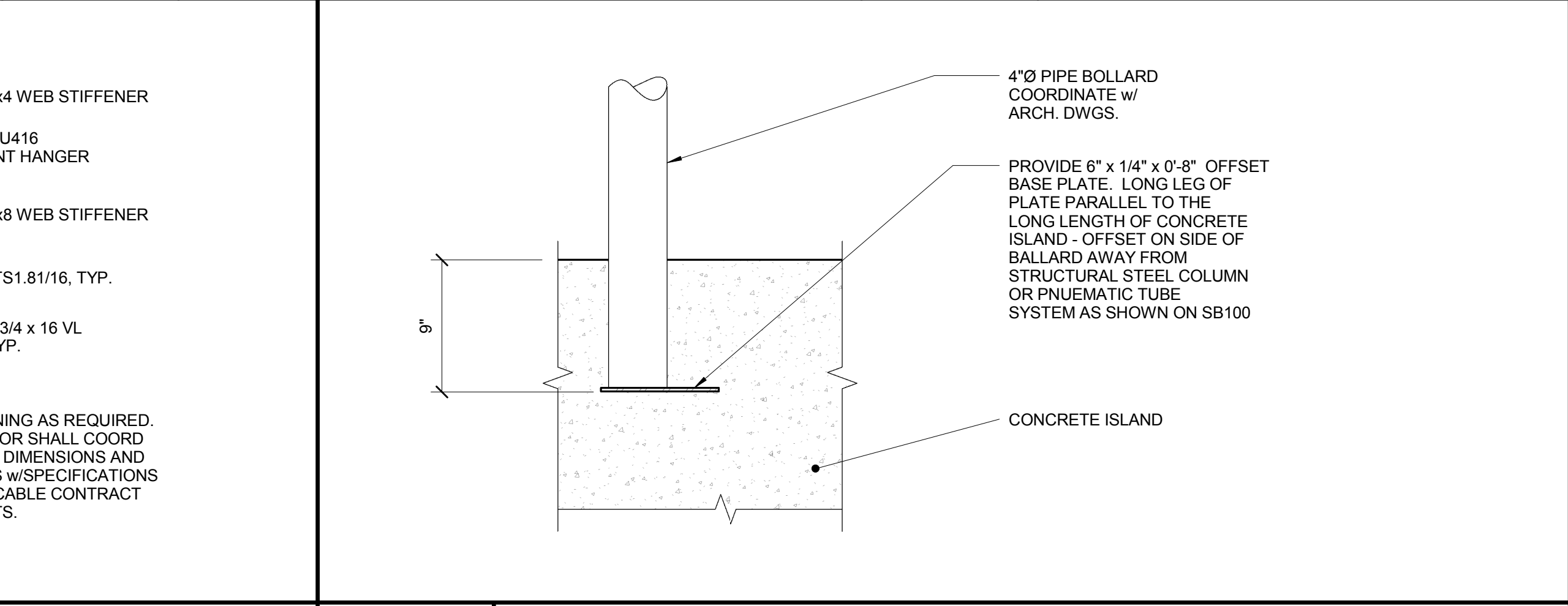
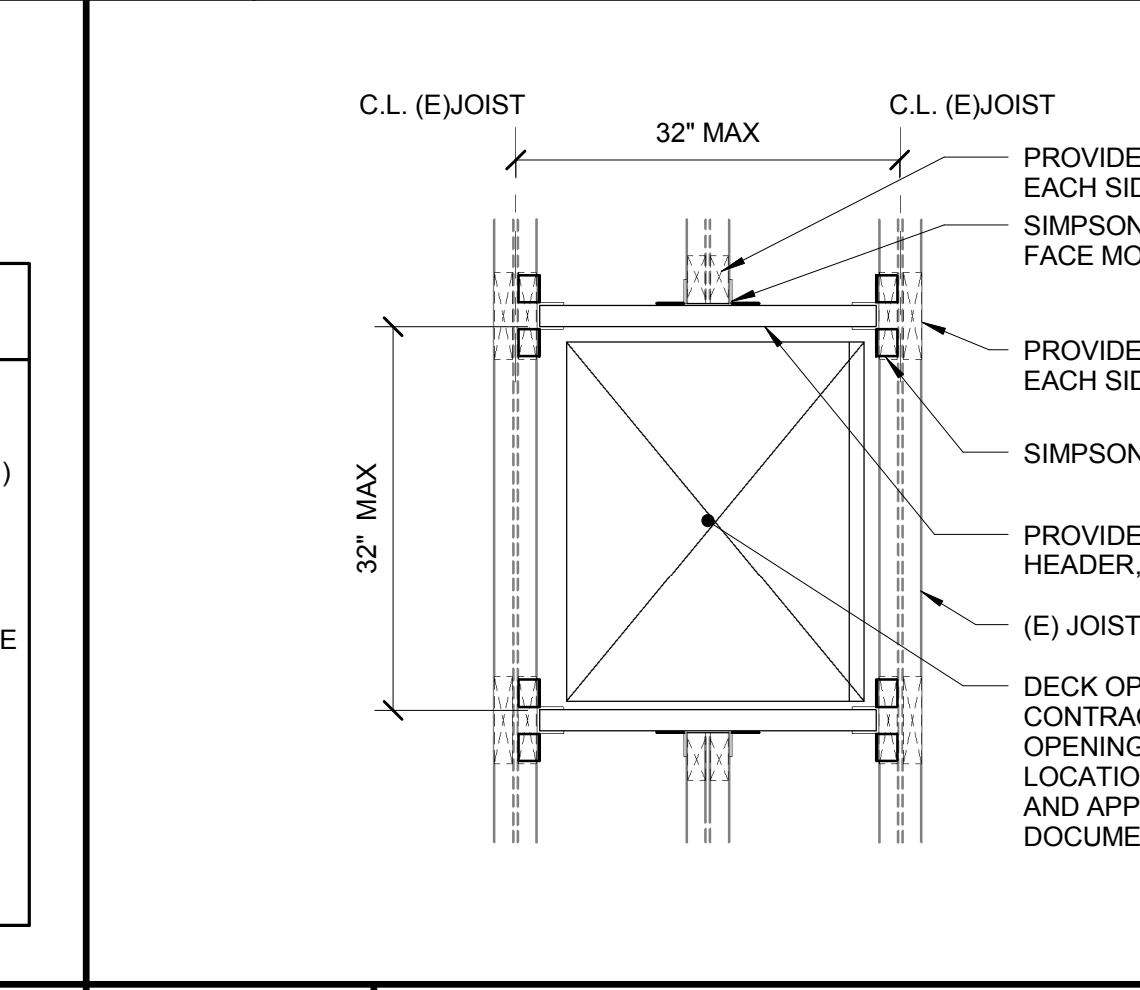
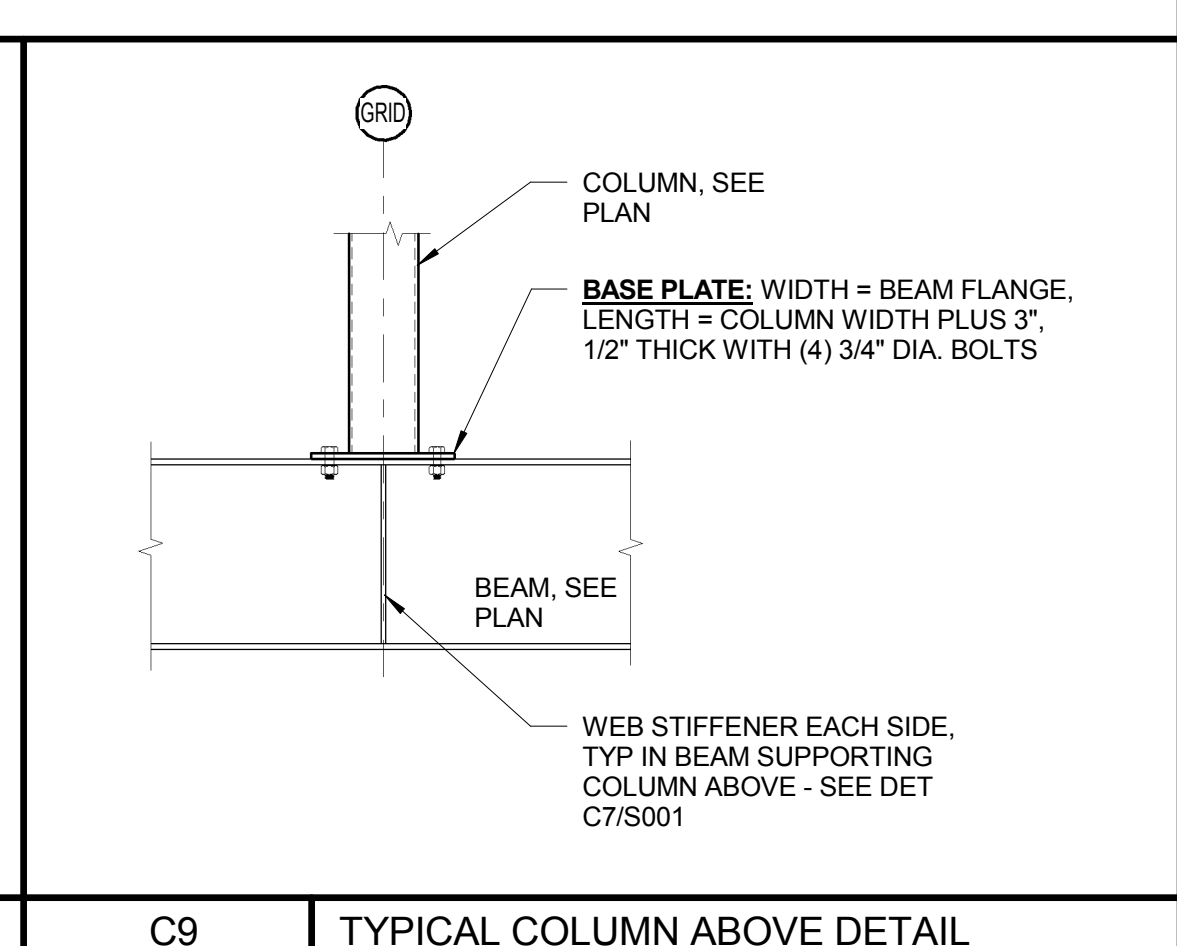
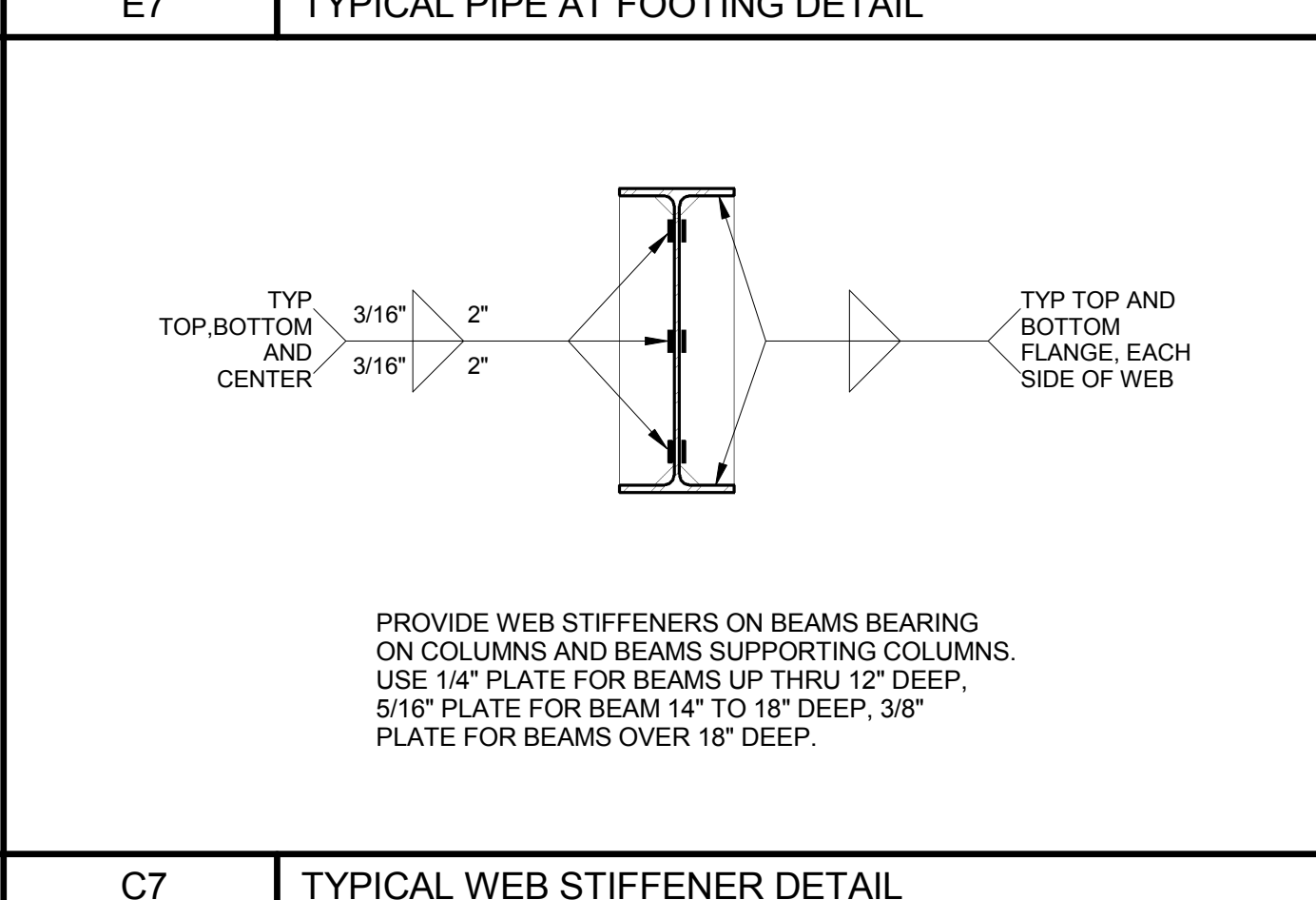
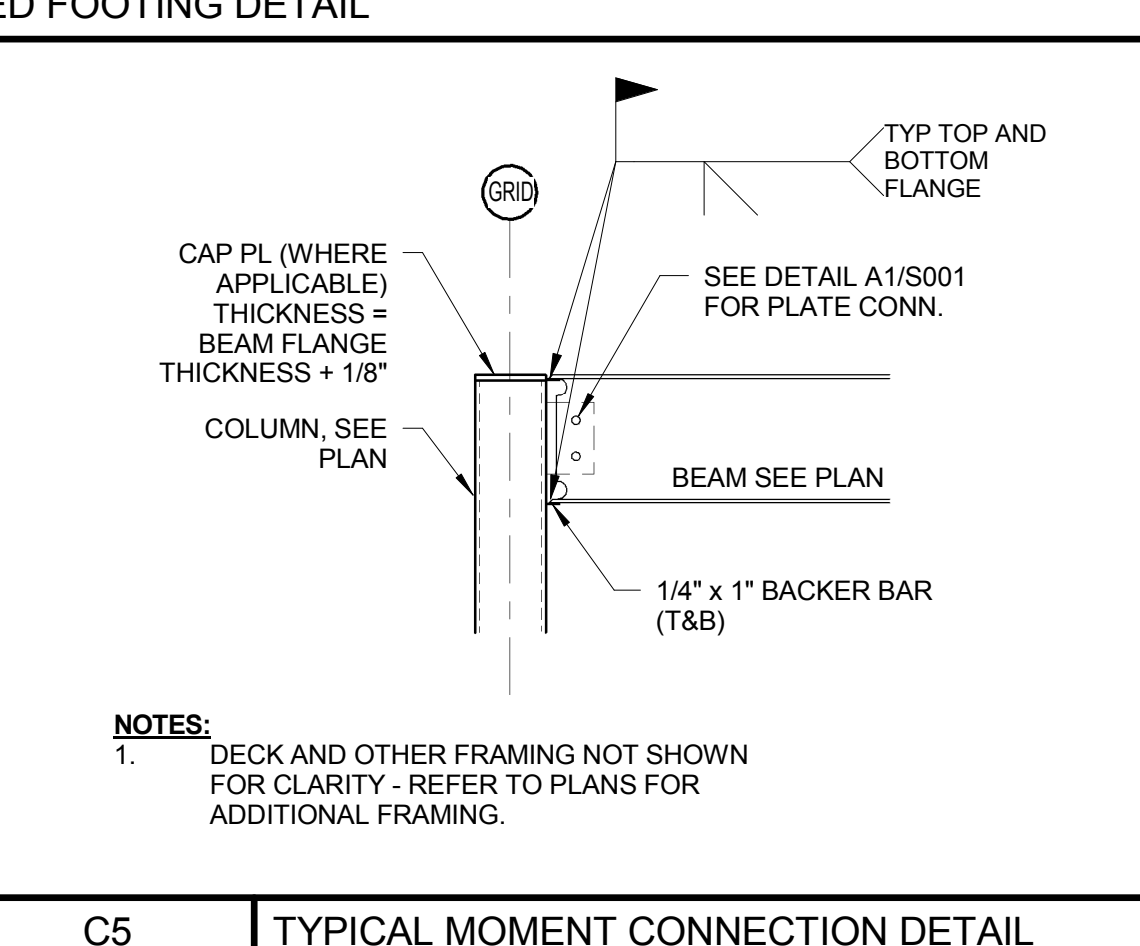

4/30/2013 8:38:56 AM N:\Projects\2013\1313008 - TruChoice Federal Credit Union - Park Ave\00 Drawing Files\13008S.rvt