

NOTE: FOR ITEMS NOT NOTED SEE SECT. 2-S3.0

MULTIPLE TOP 2X8 PLATES TO CONT. DBL. PLATE FOR LOCATION PLAN FOR LOCATION & SCHED. ON SHT. S4.0 VARIATION - POWER FASTEN TO HSS

NOTE: FOR ITEMS NOT NOTED SEE SECT. 2-S3.0

MULTIPLE TOP 2X8 PLATES TO CONT. DBL. PLATE FOR LOCATION PLAN FOR LOCATION & SCHED. ON SHT. S4.0 VARIATION - POWER FASTEN TO HSS

NOTE: FOR ITEMS NOT NOTED SEE SECT. 2-S3.0

MULTIPLE TOP 2X8 PLATES TO CONT. DBL. PLATE FOR LOCATION PLAN FOR LOCATION & SCHED. ON SHT. S4.0 VARIATION - POWER FASTEN TO HSS

NOTE: FOR ITEMS NOT NOTED SEE SECT. 2-S3.0

MULTIPLE TOP 2X8 PLATES TO CONT. DBL. PLATE FOR LOCATION PLAN FOR LOCATION & SCHED. ON SHT. S4.0 VARIATION - POWER FASTEN TO HSS

NOTE: FOR ITEMS NOT NOTED SEE SECT. 2-S3.0

MULTIPLE TOP 2X8 PLATES TO CONT. DBL. PLATE FOR LOCATION PLAN FOR LOCATION & SCHED. ON SHT. S4.0 VARIATION - POWER FASTEN TO HSS

NOTE: FOR ITEMS NOT NOTED SEE SECT. 2-S3.0

MULTIPLE TOP 2X8 PLATES TO CONT. DBL. PLATE FOR LOCATION PLAN FOR LOCATION & SCHED. ON SHT. S4.0 VARIATION - POWER FASTEN TO HSS

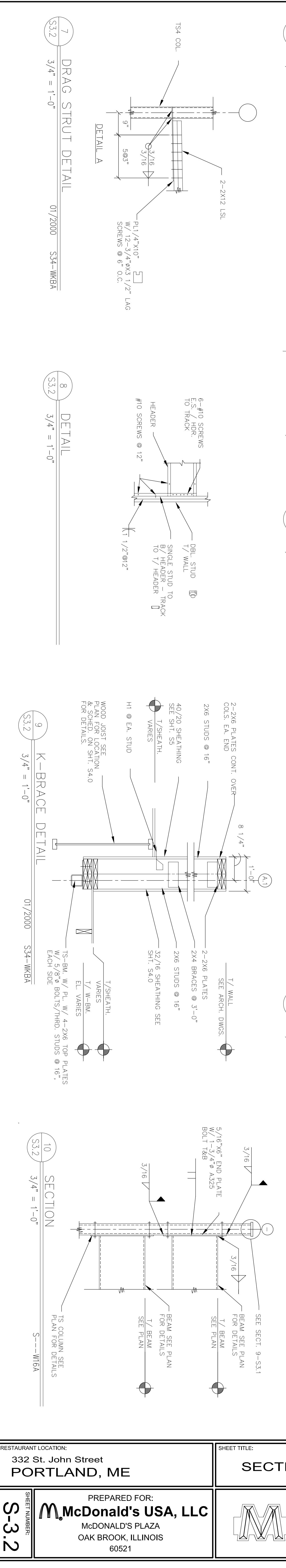
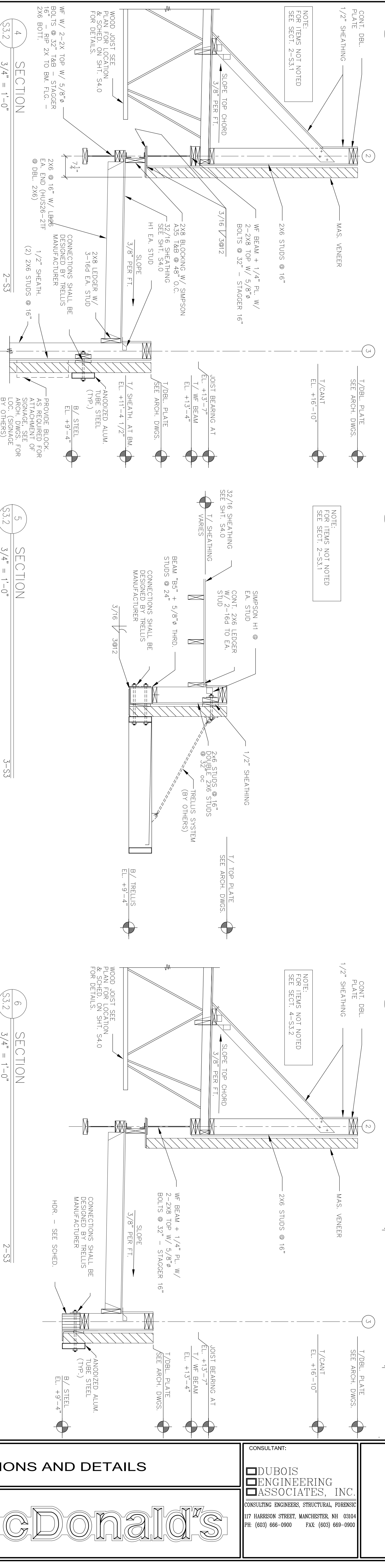
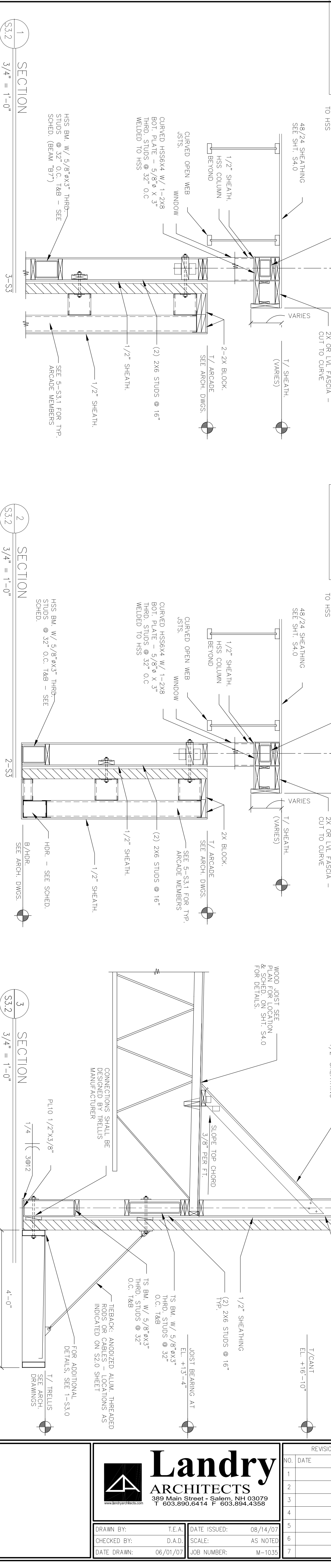

RESTAURANT LOCATION: <b>332 St. John Street          PORTLAND, ME</b>		SHEET TITLE: <b>SECTIONS AND DETAILS</b>		CONSULTANT: <b>DUBOIS          ENGINEERING          ASSOCIATES, INC.</b> <small>CONSULTING ENGINEERS, STRUCTURAL, FORENSIC          117 HARRISON STREET, MANCHESTER, NH 03041          PH: (603) 666-0900 FAX: (603) 669-0900</small>																									
PREPARED FOR: <b>McDonald's USA, LLC</b> McDONALD'S PLAZA OAK BROOK, ILLINOIS 60521				REVISIONS <table border="1"> <thead> <tr> <th>NO.</th> <th>DATE</th> <th>BY</th> </tr> </thead> <tbody> <tr><td>1</td><td></td><td></td></tr> <tr><td>2</td><td></td><td></td></tr> <tr><td>3</td><td></td><td></td></tr> <tr><td>4</td><td></td><td></td></tr> <tr><td>5</td><td></td><td></td></tr> <tr><td>6</td><td></td><td></td></tr> <tr><td>7</td><td></td><td></td></tr> </tbody> </table>		NO.	DATE	BY	1			2			3			4			5			6			7		
NO.	DATE	BY																											
1																													
2																													
3																													
4																													
5																													
6																													
7																													
SHEET NUMBER: <b>S-3.2</b>		DRAWN BY: T.E.A. CHECKED BY: D.A.D. DATE DRAWN: 06/01/07		DATE ISSUED: 06/14/07 SCALE: AS NOTED JOB NUMBER: M-1035																									