

City of Portland, Maine – Building or Use Permit Application 389 Congress Street, 04101, Tel: (207) 874-8703, FAX: 874-8716

Location of Construction: 332 St John St		Owner: McDonald's Corporation		Phone:		Permit No:	
Owner Address:		Lessee/Buyer's Name: Quintel Co/George Lydick		Phone: P.O. Box 10048		BusinessName: Ptld, ME 04104	
Contractor Name: Bailey Sign		Address:		Phone: 781-5052		Permit Issued:	
Past Use: Restaurant		Proposed Use: Same		COST OF WORK: \$		PERMIT FEE: \$ 50.60	
				FIRE DEPT. <input type="checkbox"/> Approved <input type="checkbox"/> Denied		INSPECTION: Use Group: Type:	
Proposed Project Description: Replace Existing Signage 128 Sq Ft				Signature:		Signature:	
				PEDESTRIAN ACTIVITIES DISTRICT (P.A.D.)		Zone: CBL: 065-A-012	
				Action: Approved <input type="checkbox"/> Approved with Conditions: <input type="checkbox"/> Denied <input type="checkbox"/>		Zoning Approval:	
Permit Taken By: Mary Gresik		Date Applied For: 12 March 1998		Signature:		Date:	
						Special Zone or Reviews: <input type="checkbox"/> Shoreland <input type="checkbox"/> Wetland <input type="checkbox"/> Flood Zone <input type="checkbox"/> Subdivision <input type="checkbox"/> Site Plan maj <input type="checkbox"/> minor <input type="checkbox"/> mm <input type="checkbox"/>	

1. This permit application does not preclude the Applicant(s) from meeting applicable State and Federal rules.
2. Building permits do not include plumbing, septic or electrical work.
3. Building permits are void if work is not started within six (6) months of the date of issuance. False information may invalidate a building permit and stop all work..

Zoning Appeal

Variance
 Miscellaneous
 Conditional Use
 Interpretation
 Approved
 Denied

Historic Preservation

Not in District or Landmark
 Does Not Require Review
 Requires Review

Action:

Approved
 Approved with Conditions
 Denied

Date: _____

CERTIFICATION

I hereby certify that I am the owner of record of the named property, or that the proposed work is authorized by the owner of record and that I have been authorized by the owner to make this application as his authorized agent and I agree to conform to all applicable laws of this jurisdiction. In addition, if a permit for work described in the application is issued, I certify that the code official's authorized representative shall have the authority to enter all areas covered by such permit at any reasonable hour to enforce the provisions of the code(s) applicable to such permit

George Lydick
 SIGNATURE OF APPLICANT George Lydick ADDRESS: DATE: 12 March 1998 PHONE:

RESPONSIBLE PERSON IN CHARGE OF WORK, TITLE PHONE:

White-Permit Desk Green-Assessor's Canary-D.P.W. Pink-Public File Ivory Card-Inspector

CEO DISTRICT

SIGNAGE

PLEASE ANSWER ALL QUESTIONS

ADDRESS: 332 St. John St. ZONE: B-2

OWNER: George Lydick

APPLICANT: George Lydick / Quinter Co dba McDonald's

ASSESSOR NO.: _____

SINGLE TENANT LOT? YES NO

MULTI TENANT LOT? YES NO

FREESTANDING SIGN? YES NO
(ex. pole sign..)

(irregular design)
DIMENSIONS 128 sq. ft.
replacing existing sign on pylon.

MORE THAN ONE SIGN? YES NO

DIMENSIONS _____
new one is 1855
in size frame
old one per

BLDG. WALL SIGN? YES NO
(attached to bldg)

MORE THAN ONE SIGN? YES NO

DIMENSIONS _____
all on plan for 5/97
building project
G.L.
3/18/98

LIST ALL EXISTING SIGNAGE AND THEIR DIMENSIONS: _____

LOT FRONTAGE (FEET) 410'

BLDG FRONTAGE (FEET) 54'

AWNING YES NO IS AWNING BACKLIT? YES NO

HEIGHT OF AWNING: _____

IS THERE ANY COMMUNICATION, MESSAGE, TRADEMARK OR SYMBOL ON IT? DNA

A SITE SKETCH AND BUILDING SKETCH SHOWING EXACTLY WHERE EXISTING AND NEW

SIGNAGE IS LOCATED MUST BE PROVIDED. SKETCHES AND/OR PICTURES OF THE

PROPOSED SIGNS ARE ALSO REQUIRED.

781-5052-07a
- George Lydick
- St. John St

The region is not
any bigger
Height - same
surface area smaller
(could smaller?)

90-200 ROAD SIGN/REDUCED EMBLEM

18
5 1/2
7 1/2
128

new sign

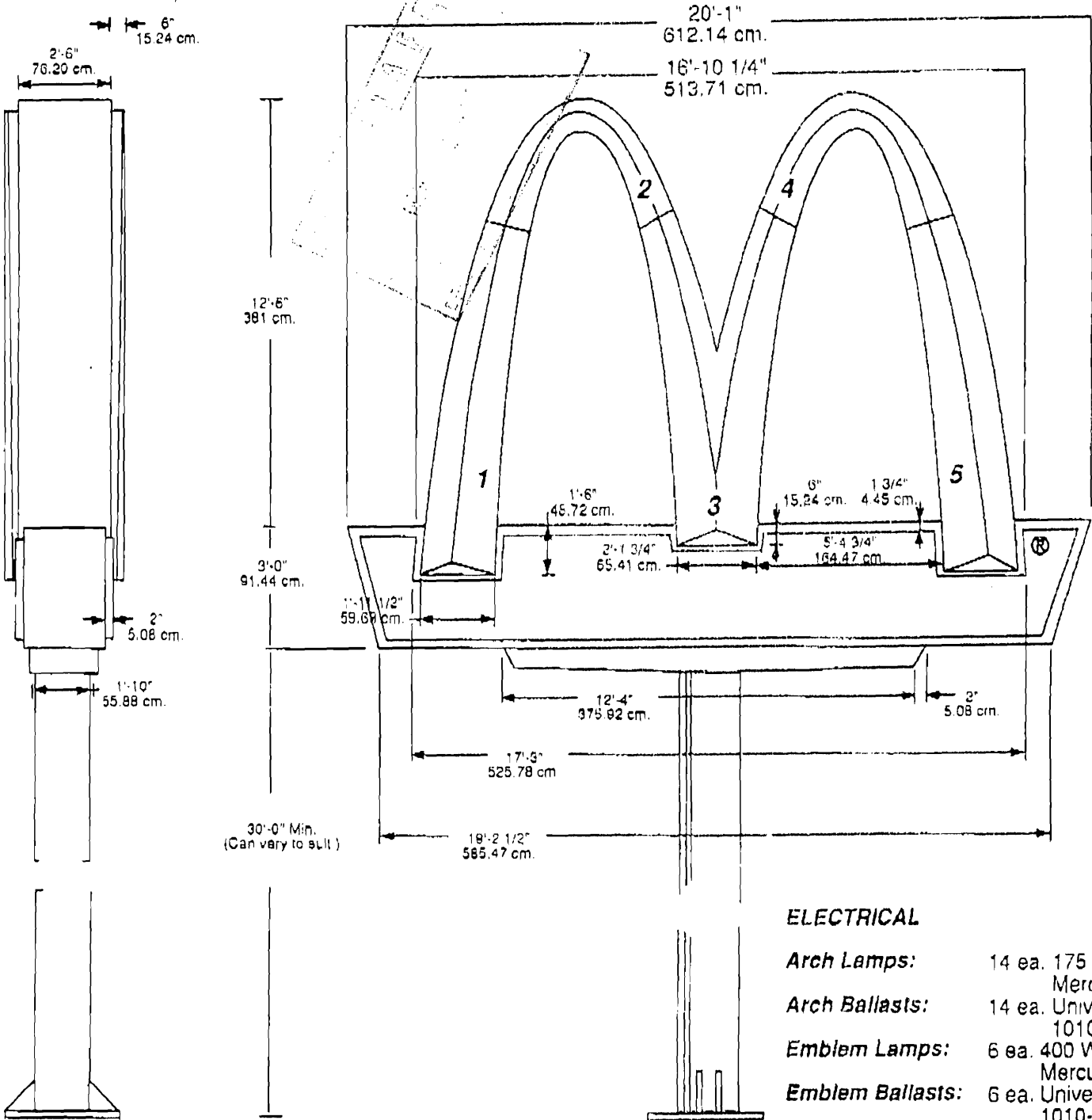

ELECTRICAL

- Arch Lamps:** 14 ea. 175 W Mercury Vapor
- Arch Ballasts:** 14 ea. Universal 1010-245C-TC
- Emblem Lamps:** 6 ea. 400 W Mercury Vapor
- Emblem Ballasts:** 6 ea. Universal 1010-247S-CTC
- Service:** 4 ea. 20 Amp Circuits, 120V, 60HZ
- Load:** 46.6 Amps

UL# E37006

Plasti-Line The-manuf