

1 ACCESSIBLE PARKING & VAN ACCESSIBLE PARKING DETAIL NOT TO SCALE

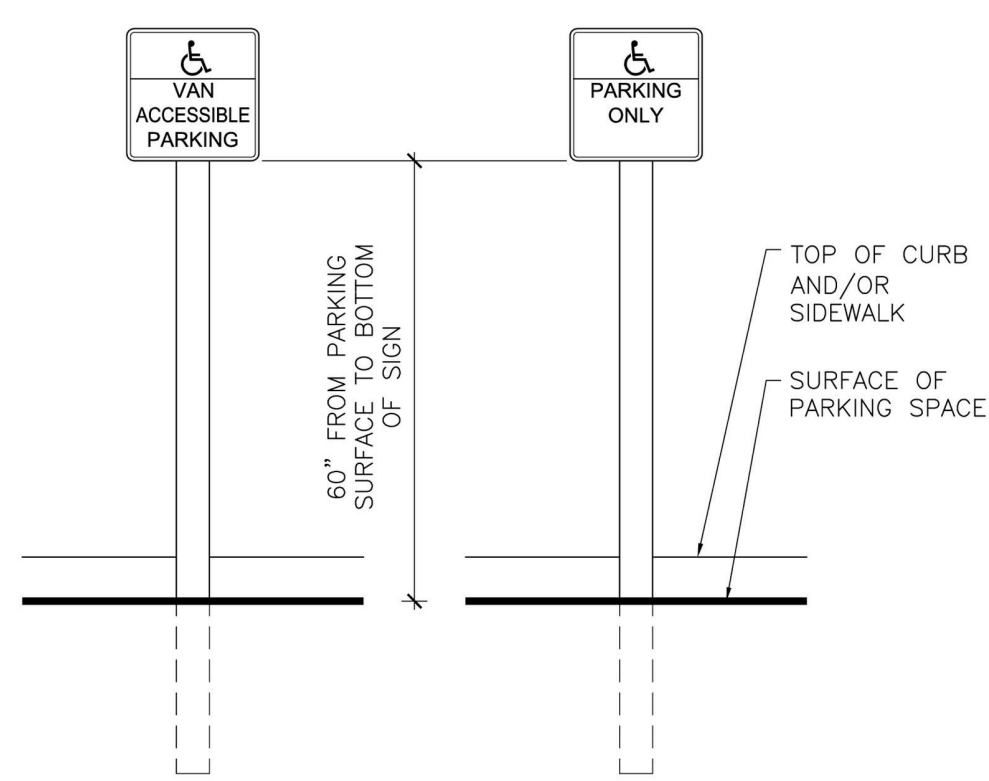

2 ACCESSIBLE PARKING SIGNAGE DETAIL NOT TO SCALE

TOTAL NUMBER OF PARKING SPACES PROVIDED IN PARKING FACILITY	MINIMUM NUMBER OF REQUIRED ACCESSIBLE PARKING SPACES
1 TO 25	1
26 TO 50	2
51 TO 75	3
76 TO 100	4
101 TO 150	5
151 TO 200	6
201 TO 300	7
301 TO 400	8
401 TO 500	9
501 TO 1000	2% OF TOTAL
1001 AND OVER	20, PLUS 1 FOR EACH 100, OR FRACTION THEREOF, OVER 1000

NOTE: FOR EVERY 6 OR FRACTION OF SIX ACCESSIBLE PARKING SPACES PROVIDED, ONE SHALL BE A VAN ACCESSIBLE PARKING SPACE.

- NOTES:
- DIMENSIONS OF PARKING SPACES AND ACCESS AISLES ARE MEASURED FROM THE CENTERLINE OF MARKING (STRIPES).
  - PARKING SPACES FOR VANS, ACCESS AISLES, AND VEHICULAR ROUTES SERVING THEM SHALL HAVE A VERTICAL CLEARANCE OF 98" MINIMUM.
  - THE ACCESS AISLE SHALL ADJOIN AN ACCESSIBLE ROUTE THAT CONNECTS PARKING SPACES TO ACCESSIBLE ENTRANCES.
  - PARKING SPACES AND ACCESS AISLES SHALL BE DESIGNED SO THAT CARS AND VANS, WHEN PARKED, CANNOT OBSTRUCT THE REQUIRED CLEAR WIDTH OF ADJACENT ACCESSIBLE ROUTES.
  - REFER TO STATE AND LOCAL CODES FOR PAVEMENT MARKING REQUIREMENTS.

3 ACCESSIBLE PARKING COUNT TABLE & PARKING NOTES NO SCALE

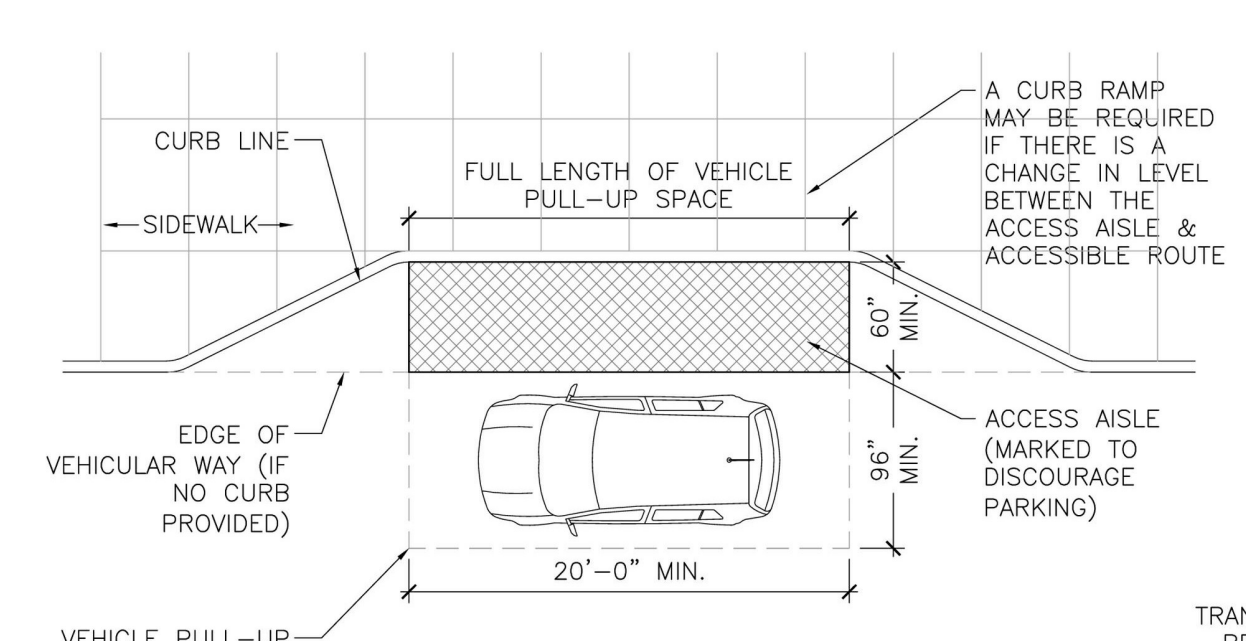

- NOTES:
- THE ACCESS AISLE SHALL ADJOIN AN ACCESSIBLE ROUTE AND MAY NOT OVERLAP THE VEHICULAR WAY.
  - IF THE ACCESSIBLE ROUTE (SIDEWALK) IS NOT LEVEL WITH THE ACCESS AISLE, AN ACCESSIBLE RAMP OR CURB RAMP MUST BE PROVIDED.
  - ACCESS AISLES SHALL BE AT THE SAME LEVEL AS THE VEHICLE PULL-UP SPACE THEY SERVE. CHANGES IN LEVEL ARE NOT PERMITTED.
  - THE SLOPE OF THE VEHICLE PULL-UP SPACES AND ACCESS AISLES SERVING THEM SHALL NOT EXCEED 2% IN ANY DIRECTION.
  - VEHICLE PULL-UP SPACES, ACCESS AISLES SERVING THEM, AND A VEHICULAR ROUTE FROM AN ENTRANCE TO THE PASSENGER LOADING ZONE, AND FROM THE PASSENGER LOADING ZONE TO A VEHICULAR EXIT SHALL HAVE A VERTICAL CLEARANCE OF 114" MINIMUM.
  - THE ACCESS AISLE MUST BE MARKED (I.E. A VARIATION IN THE SURFACE MATERIAL OR STRIPING) TO PREVENT CARS FROM PARKING IN THE AREA.

4 ACCESSIBLE PASSENGER DROP-OFF DETAIL NOT TO SCALE

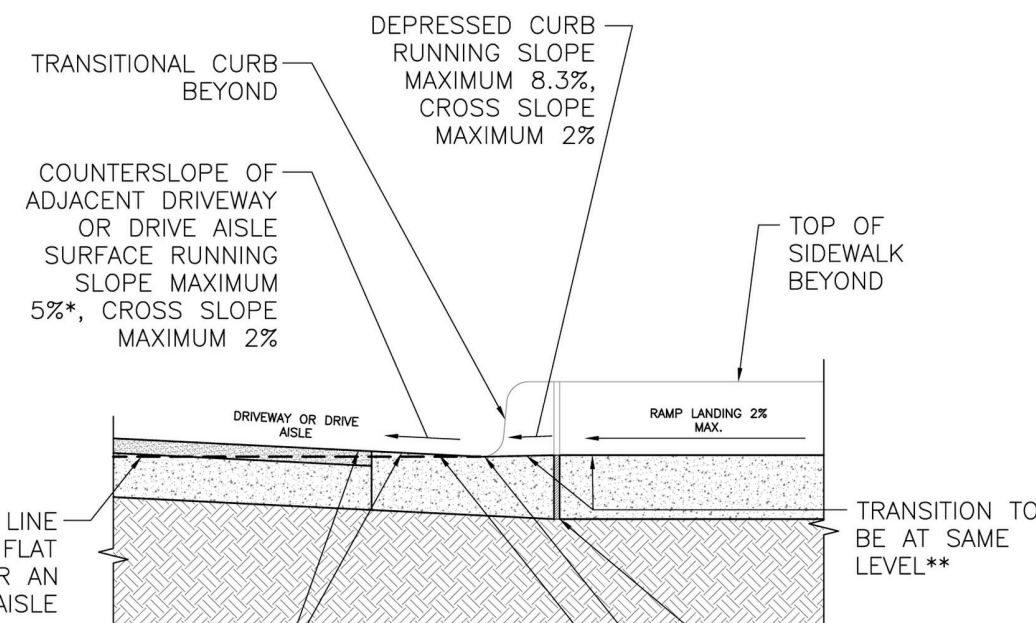
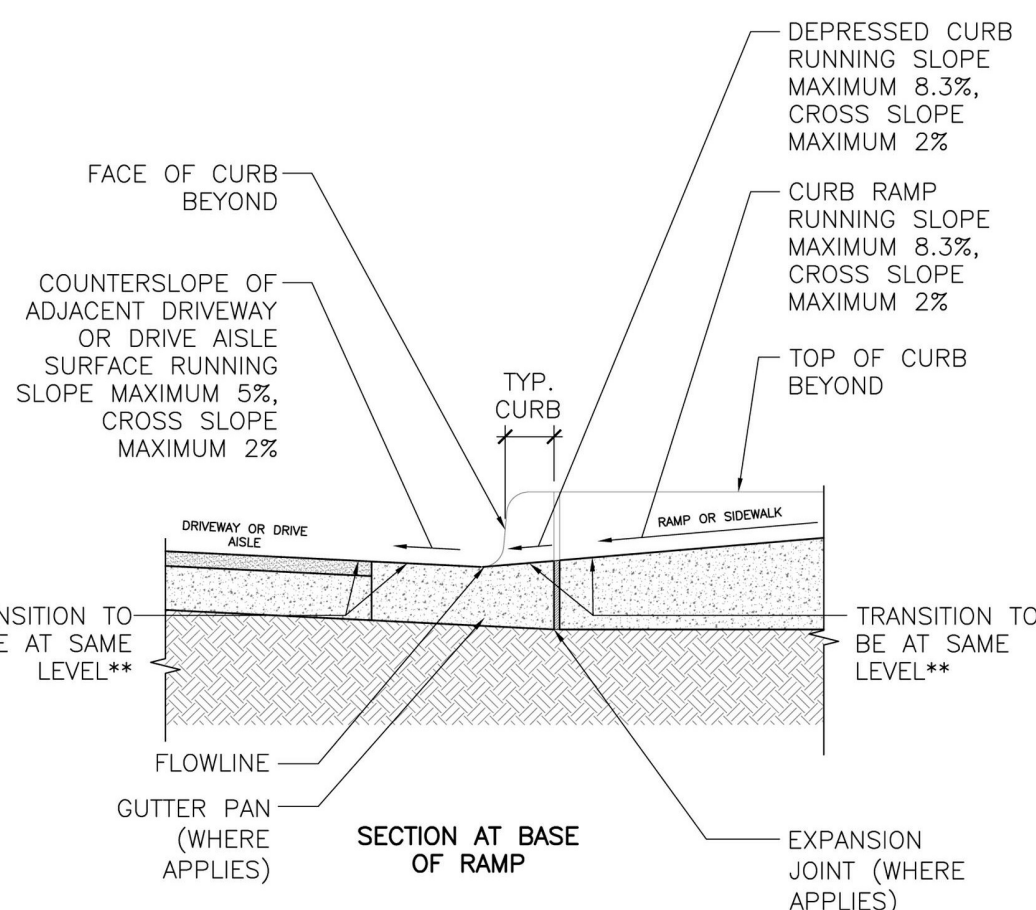

5 BOTTOM OF CURB RAMP DETAIL NOT TO SCALE

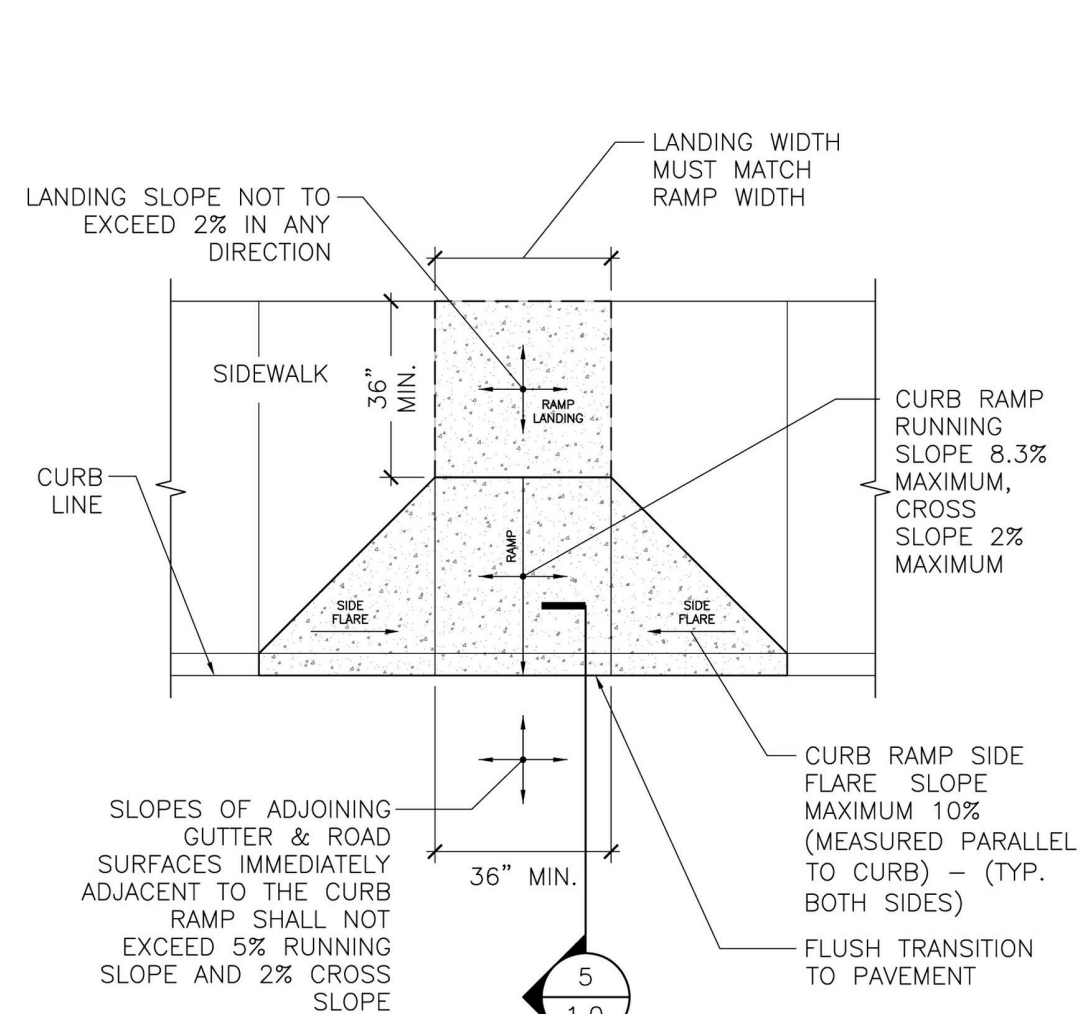

6 PERPENDICULAR CURB RAMP DETAIL NOT TO SCALE

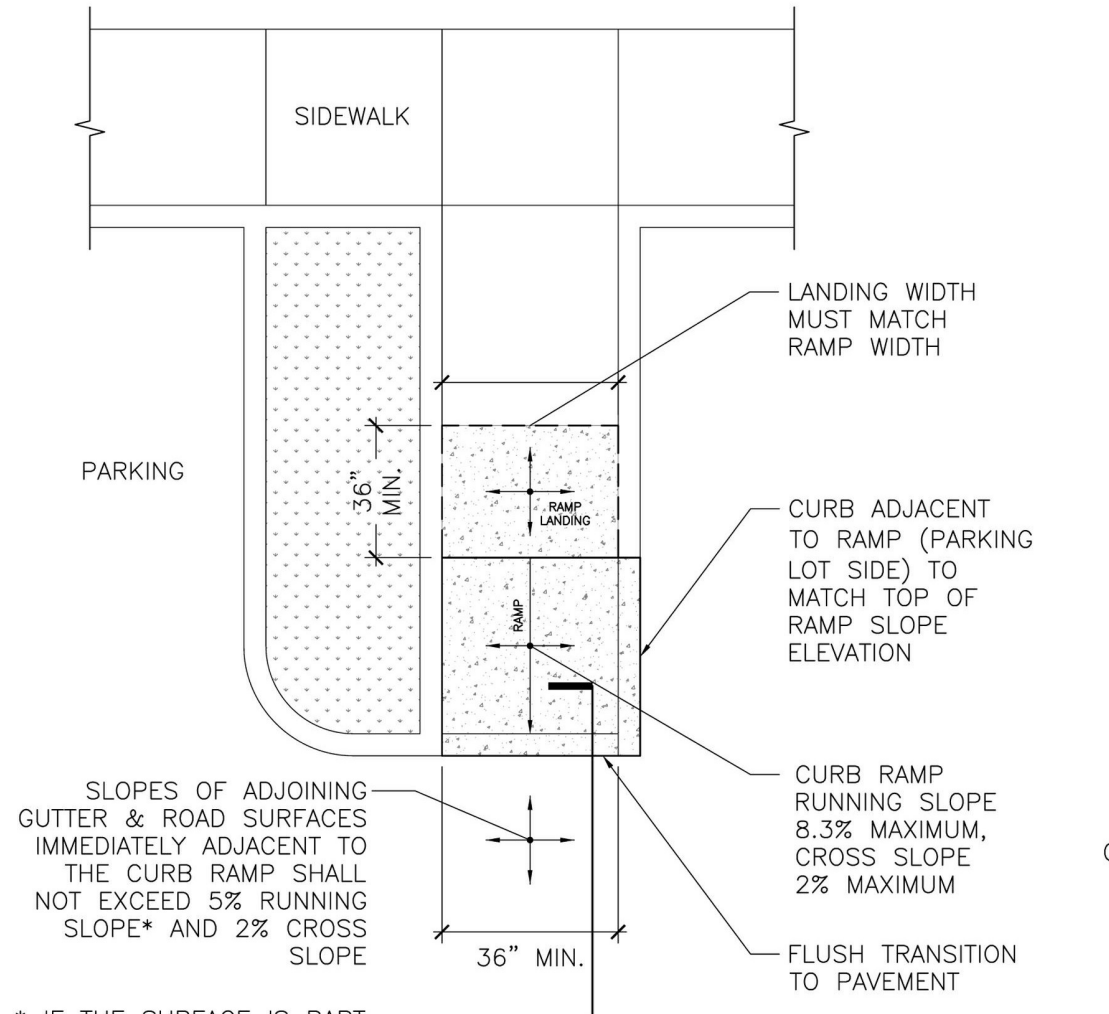

7 PERPENDICULAR CURB RAMP AT PARKING ISLAND DETAIL NOT TO SCALE

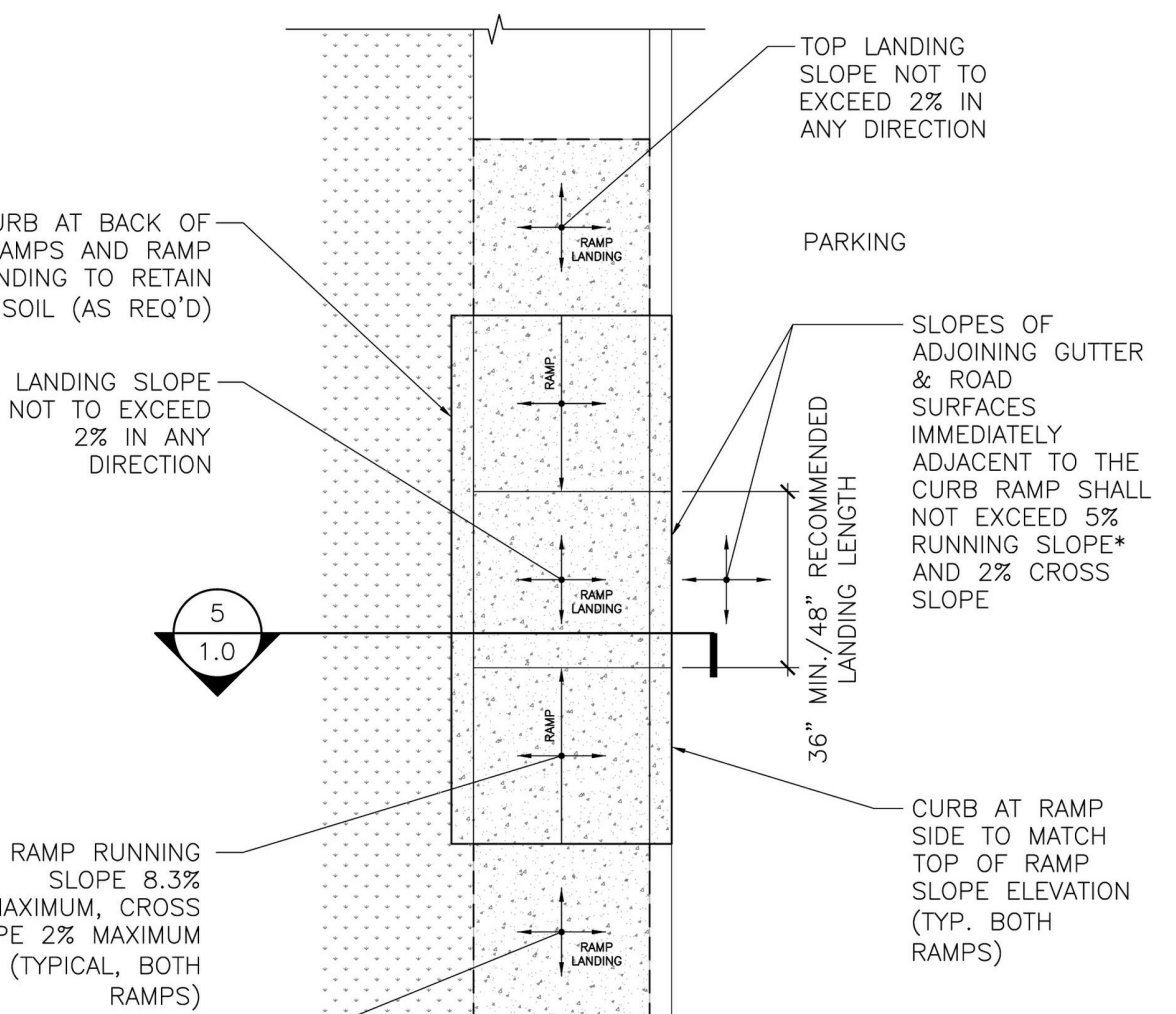

8 IN-LINE CURB RAMP DETAIL NOT TO SCALE

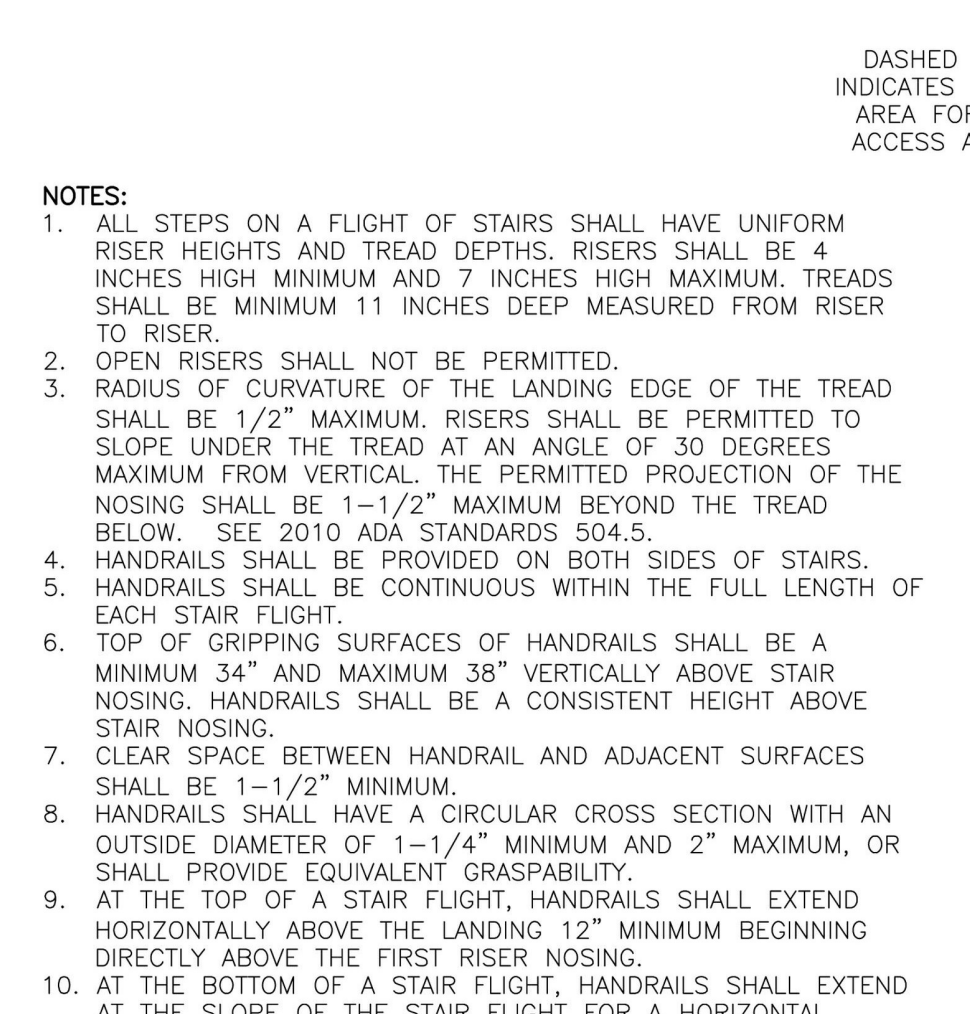

9 STAIR & STAIR HANDRAIL DETAIL NOT TO SCALE

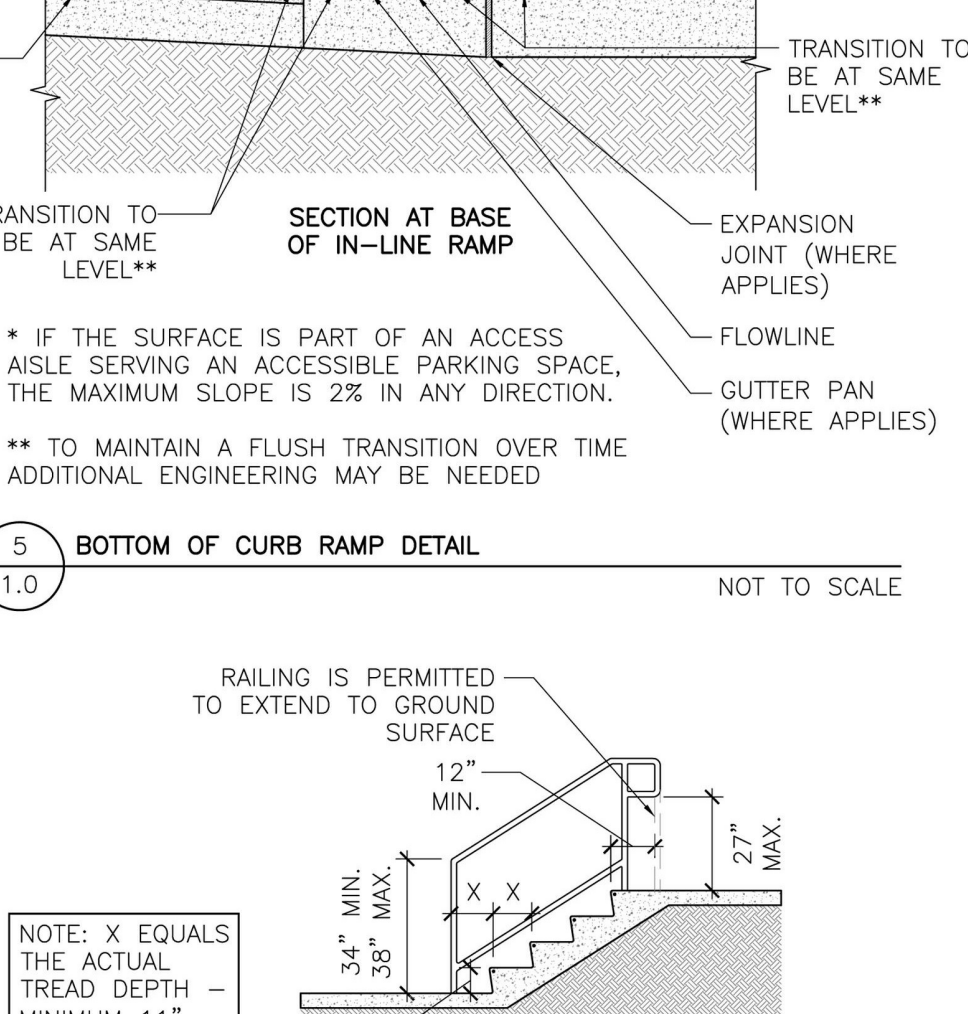

10 RAMP & RAMP HANDRAIL DETAIL NOT TO SCALE

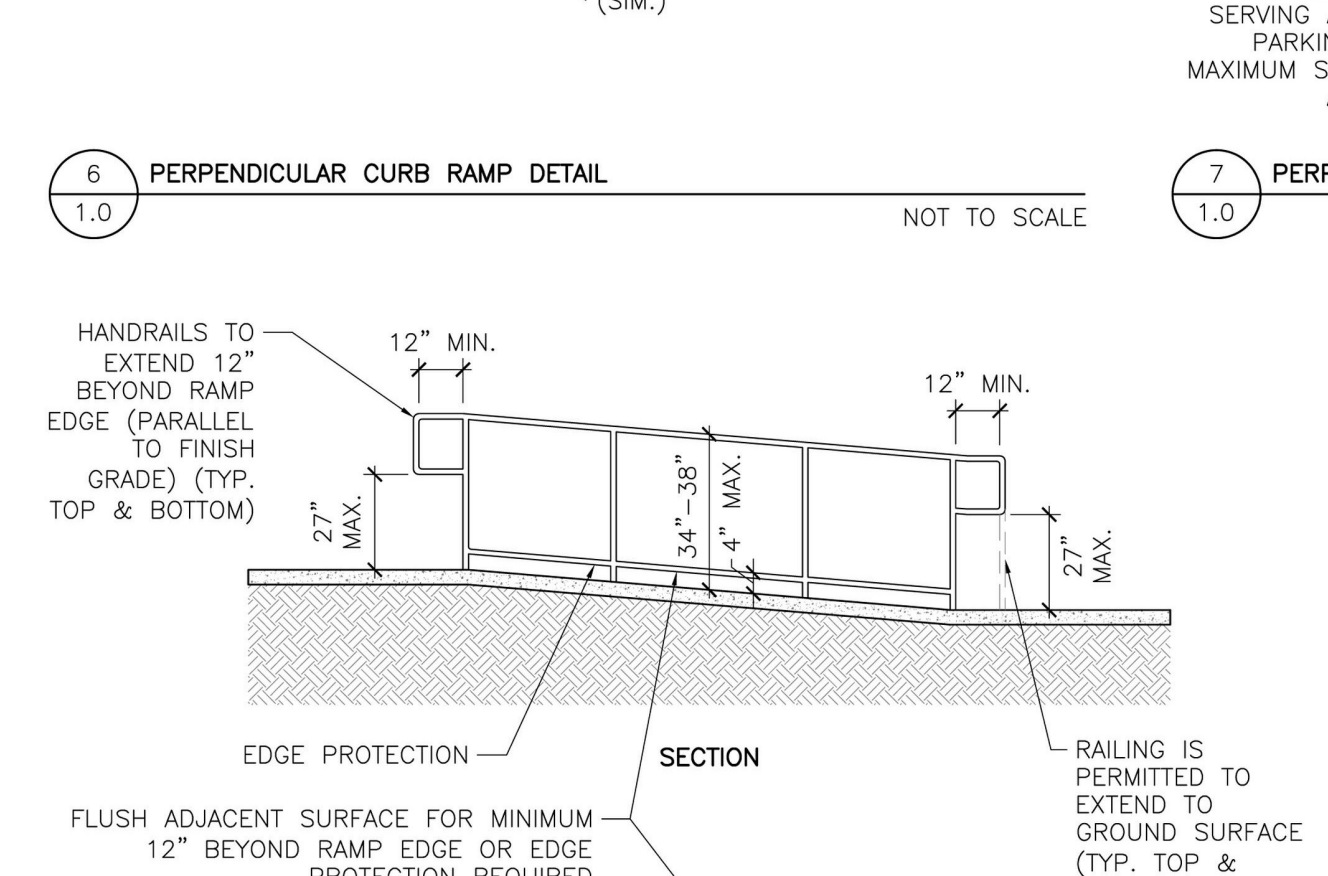

11 ACCESSIBLE ROUTE CLEAR WIDTH AND SLOPE DETAIL NOT TO SCALE

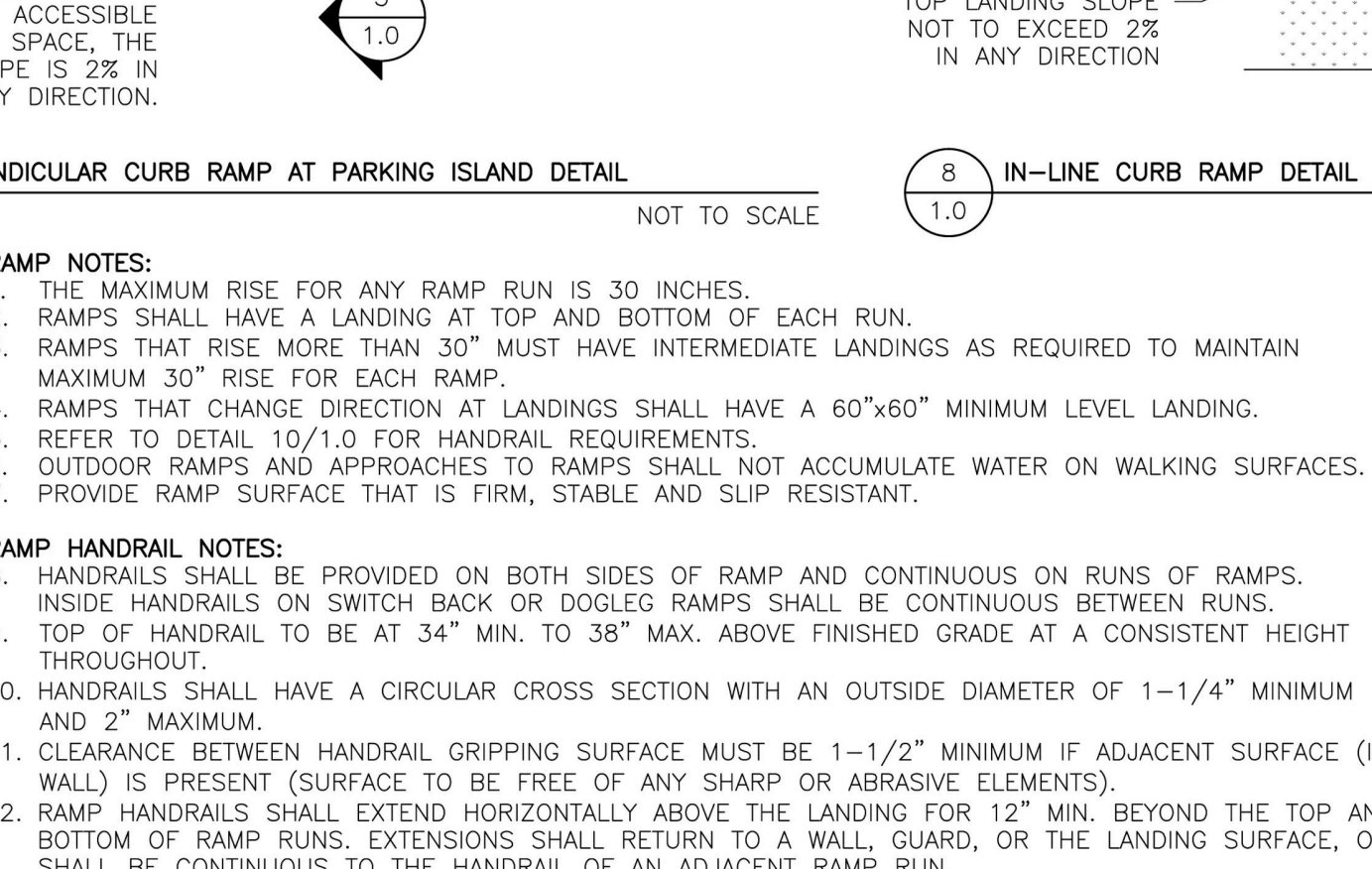

12 ACCESSIBLE ROUTE CLEAR WIDTH AT TURN (AROUND OBSTRUCTION) AND SLOPE DETAIL NOT TO SCALE

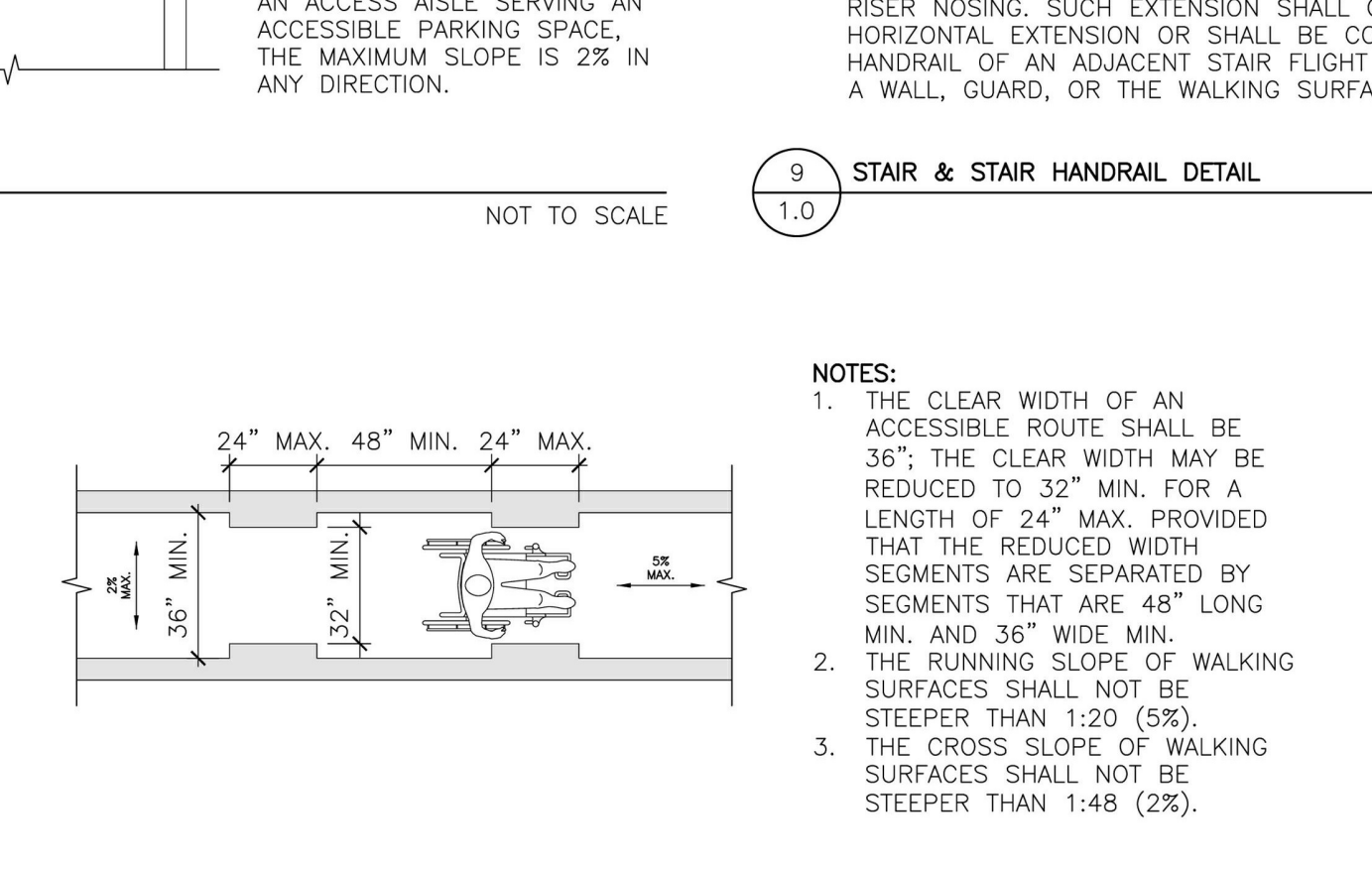

13 VERTICAL LEVEL CHANGE ON ACCESSIBLE ROUTE DETAIL NOT TO SCALE

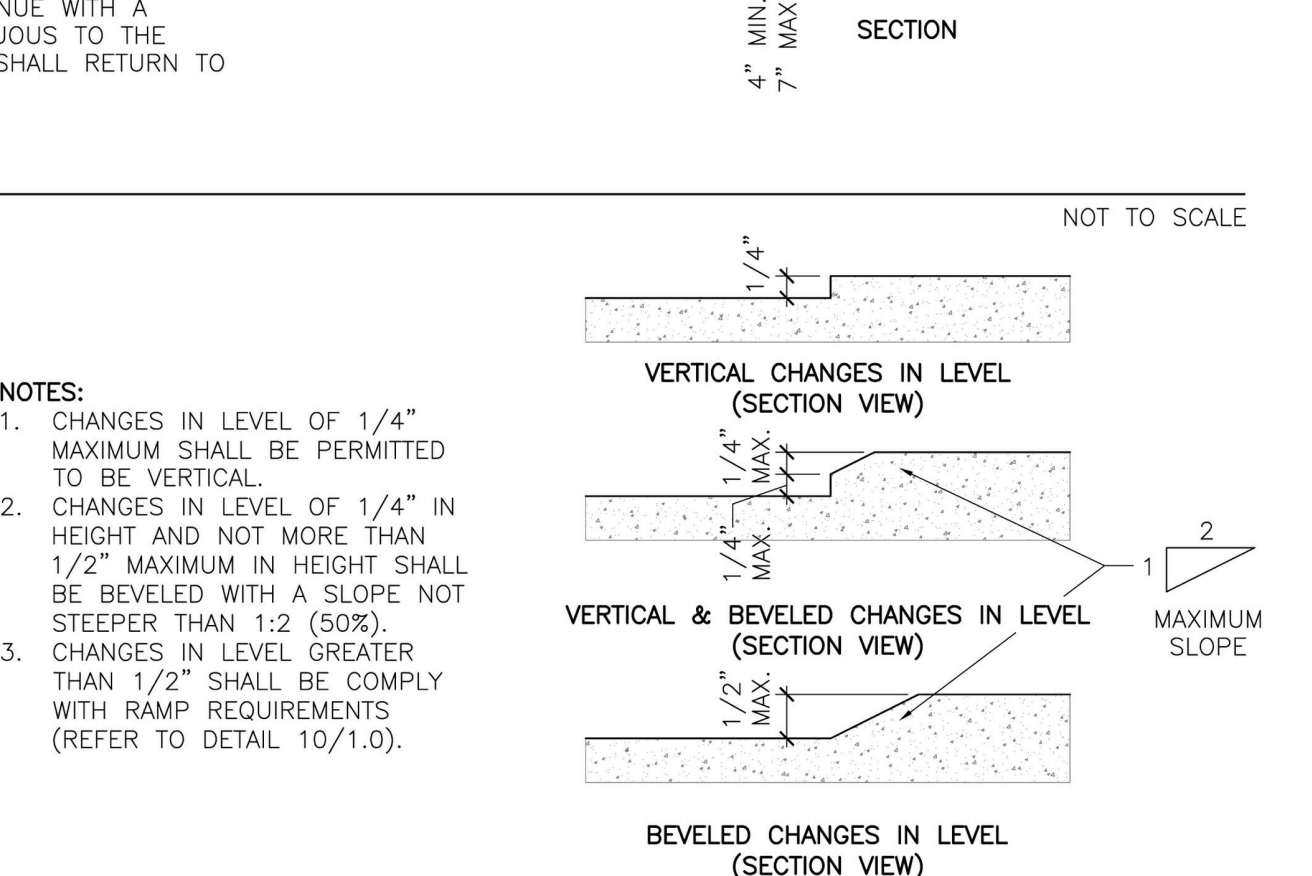

14 GAP OR OPENING ON ACCESSIBLE ROUTE DETAIL NOT TO SCALE

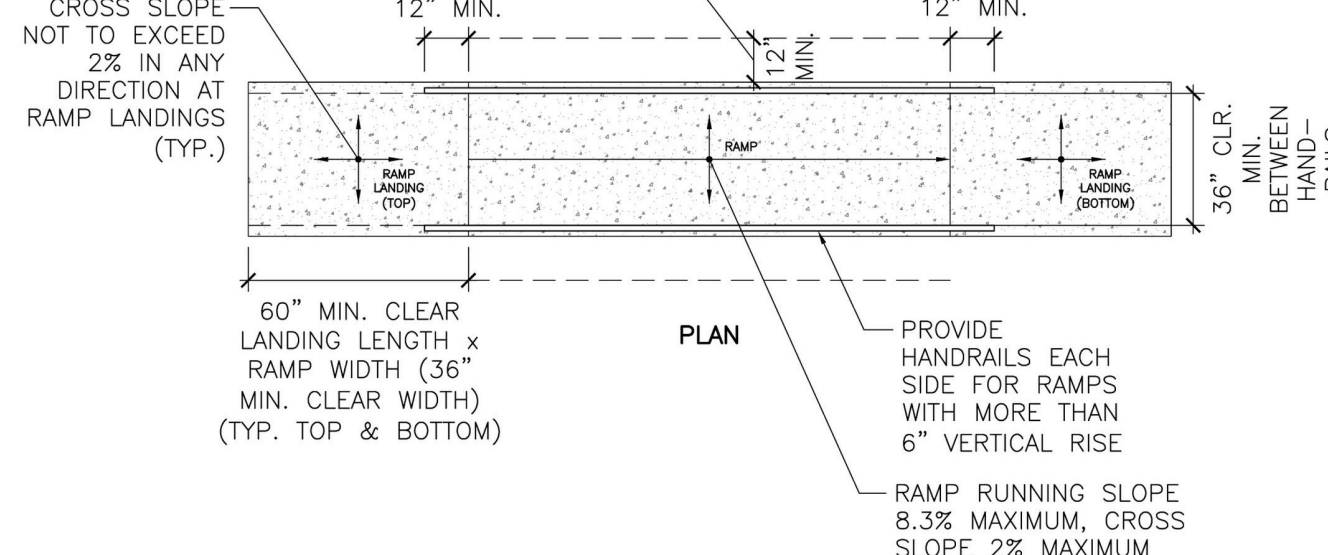

15 RAMP & RAMP HANDRAIL DETAIL NOT TO SCALE

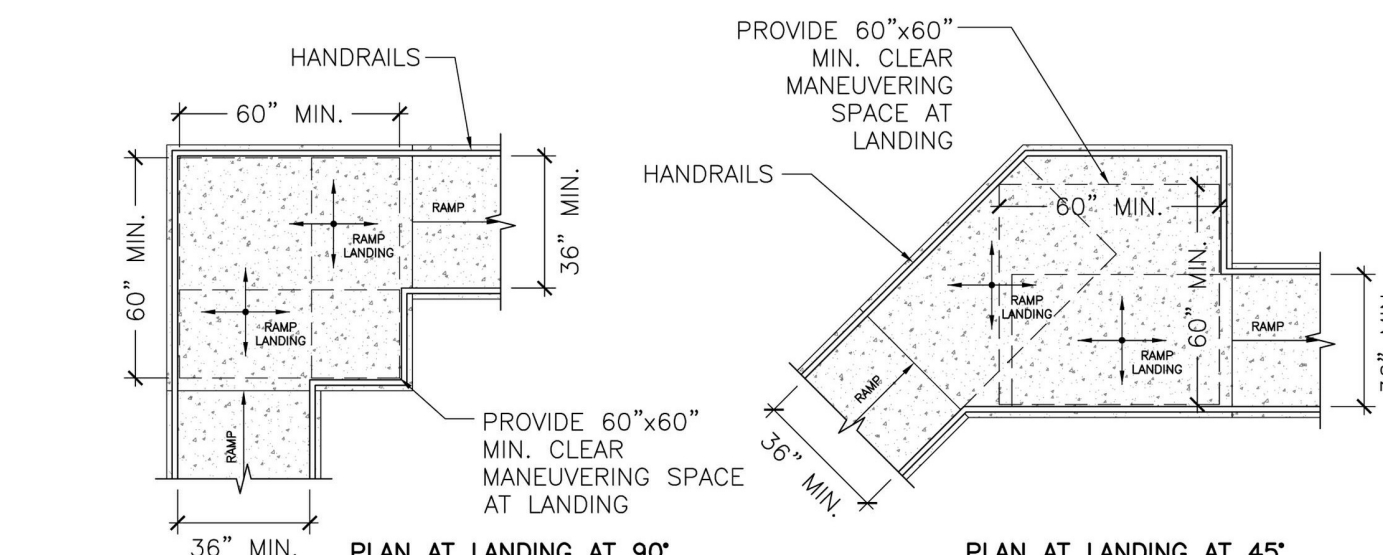

16 ACCESSIBLE ROUTE CLEAR WIDTH AT TURN (AROUND OBSTRUCTION) AND SLOPE DETAIL NOT TO SCALE

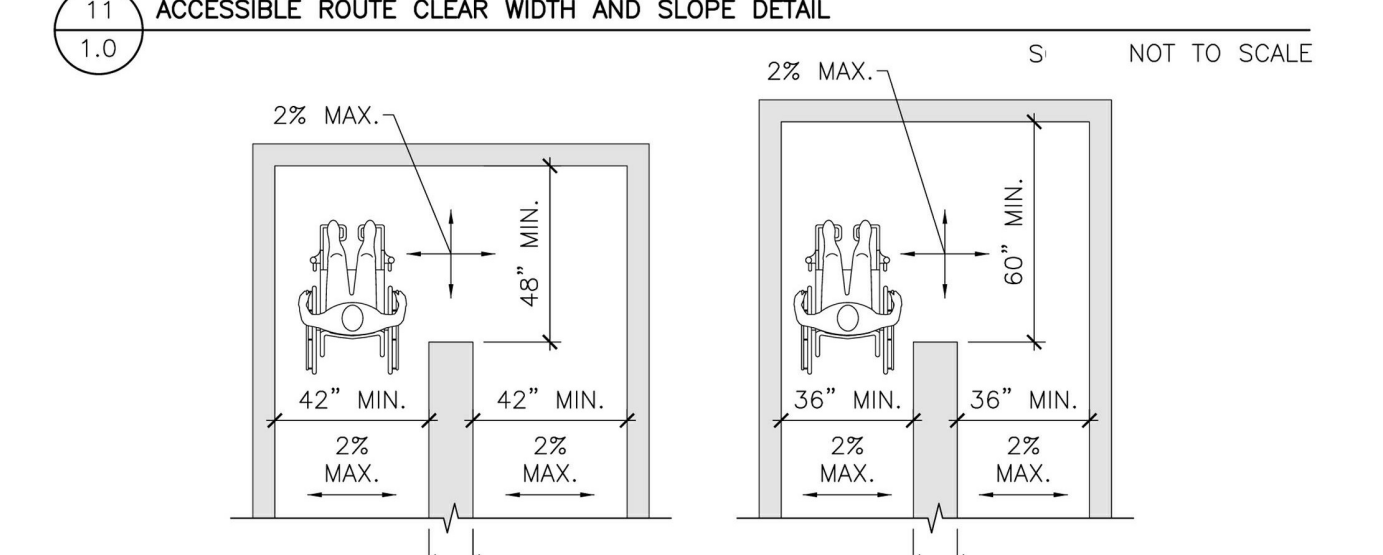

17 VERTICAL LEVEL CHANGE ON ACCESSIBLE ROUTE DETAIL NOT TO SCALE

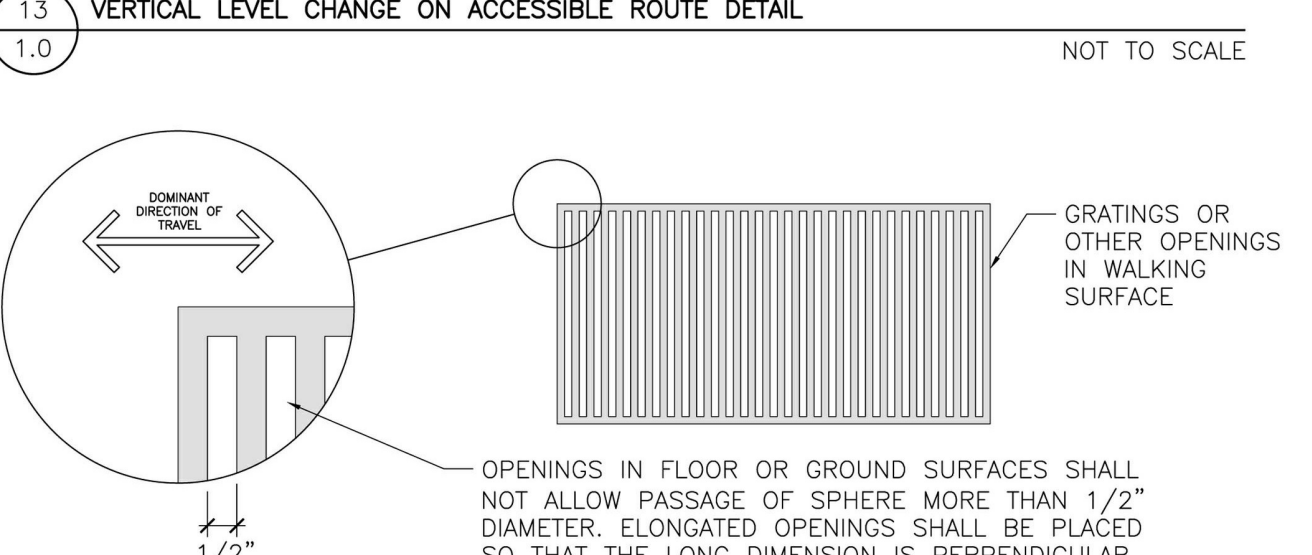

18 GAP OR OPENING ON ACCESSIBLE ROUTE DETAIL NOT TO SCALE

Project: **LAQUINTA INNS & SUITES**  
**PORTLAND, ME LQ #2049 RENOVATION**  
 340 Park Avenue, Portland, ME 04102

Project Owner: **LQ MANAGEMENT, LLC**  
 909 HIDDEN RIDGE, SUITE 600 IRVING, TEXAS 75038

Architect: **BMA** Professional Corporation  
**BMA Architectural Group** Architects ■ Designers ■ Planners  
 12 Middle Street  
 Amherst, New Hampshire 03031  
 TEL 603 673 1991 FAX 603 672 1385  
 www.bmaworld.com

Seal: **LICENSED ARCHITECT**  
 ROLF K. BIGGERS  
 No. 2597  
 STATE OF MAINE

BMA COPYRIGHT: These plans are copyrighted and are subject to copyright protection as an "architectural work" under Sec. 102 of the Copyright Act, 17 U.S.O. as amended December 1990 and known as Architectural Works Copyright Protection Act of 1990. The protection includes but is not limited to the overall form as well as the arrangement and composition of spaces and elements of the design. Under such protection, unauthorized use of these plans, work or home represented, can legally result in the cessation of construction or buildings being seized and/or monetary compensation to BMA, P.C.

REVISIONS

Job Number: 3039  
 Drawn By: Author  
 Checked By: RKB  
 Phase: CANOPY DOCUMENTS

Drawing Title: **GENERAL ACCESSIBILITY GUIDELINES**

SHEET NUMBER: **G-002**  
 DATE: 30 JUNE, 2017