

**E1 INT ELEV - BREAKFAST PANTRY**  
 1/4" = 1'-0"

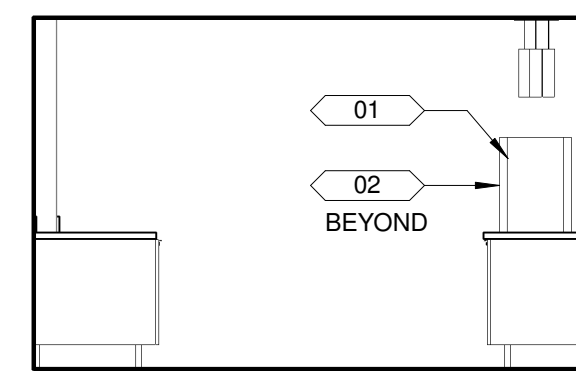

**E2 INT ELEV - BREAKFAST PANTRY**  
 1/4" = 1'-0"

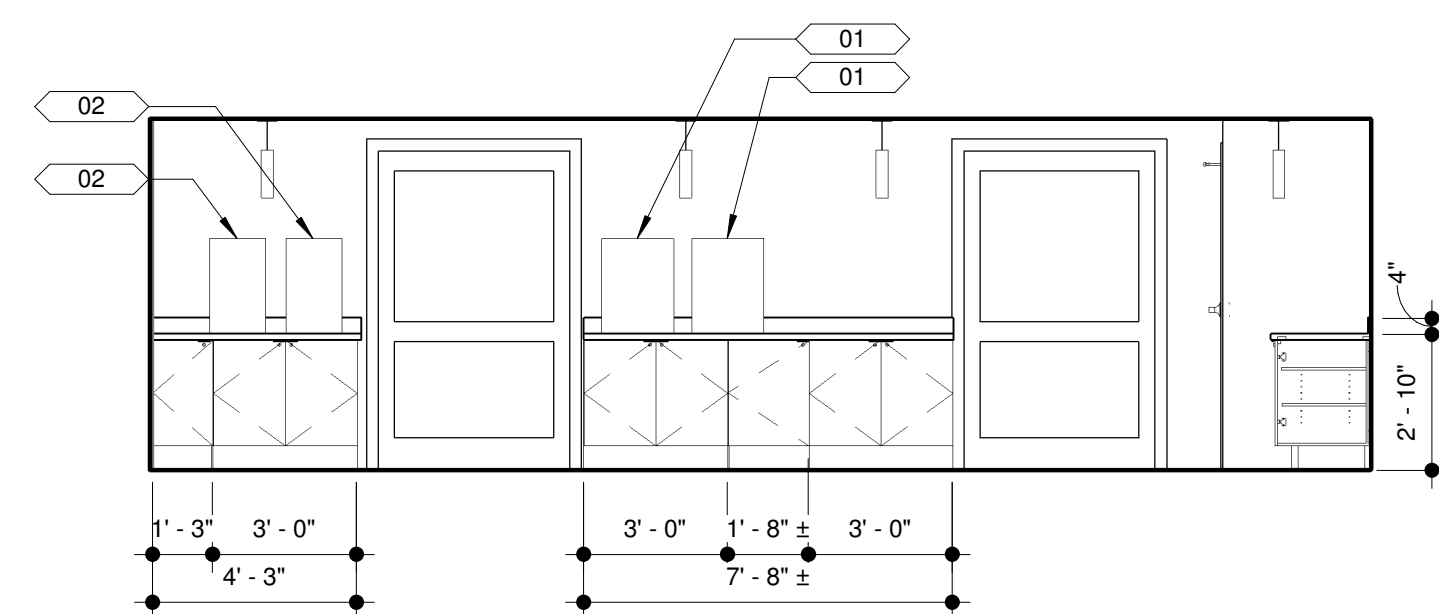

**E4 INT ELEV - BREAKFAST PANTRY**  
 1/4" = 1'-0"

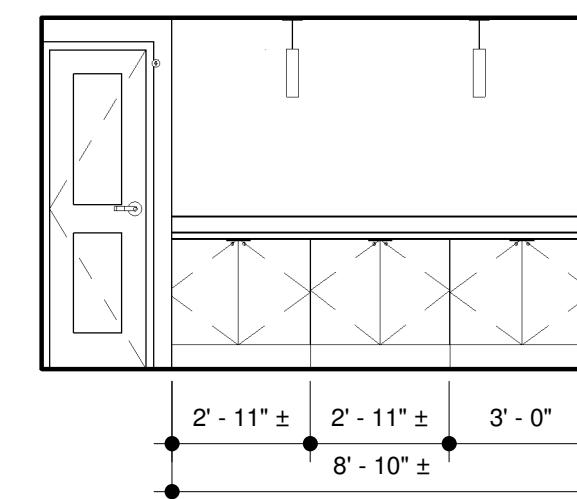

**E5 INT ELEV - BREAKFAST PANTRY**  
 1/4" = 1'-0"

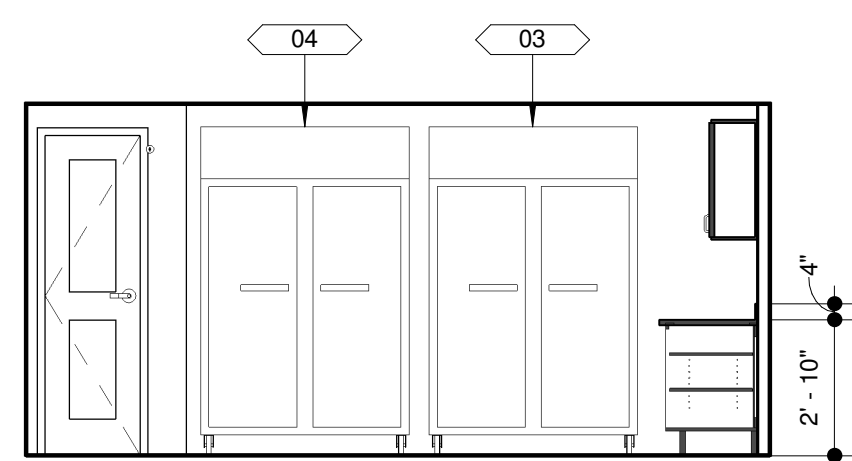

**D1 INT. ELEV - KITCHEN - 1**  
 1/4" = 1'-0"

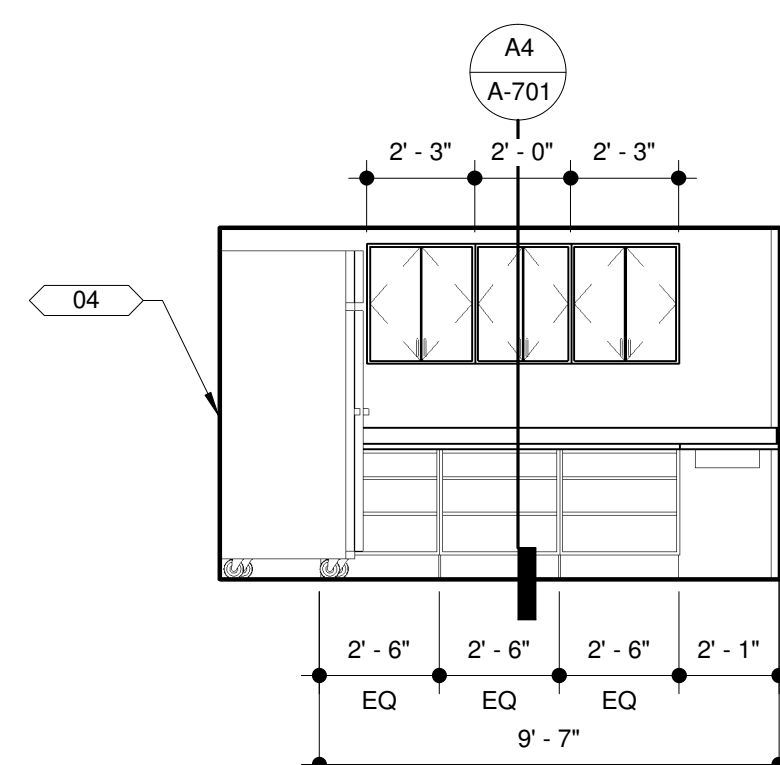

**D2 INT. ELEV - KITCHEN - 2**  
 1/4" = 1'-0"

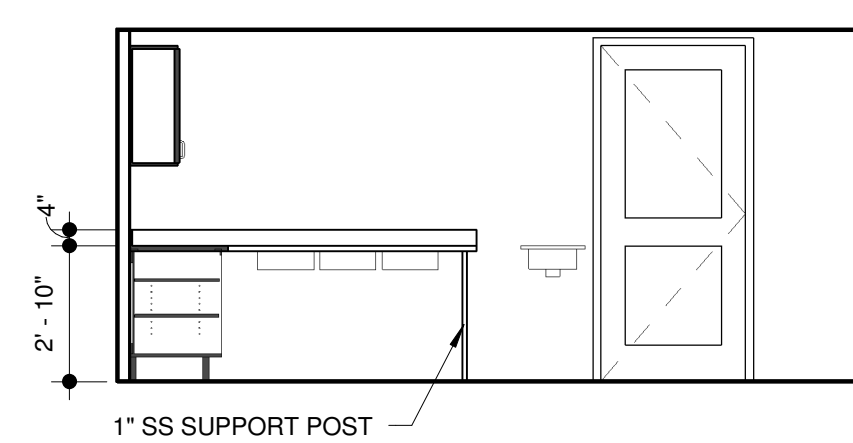

**D4 INT. ELEV - KITCHEN - 3**  
 1/4" = 1'-0"

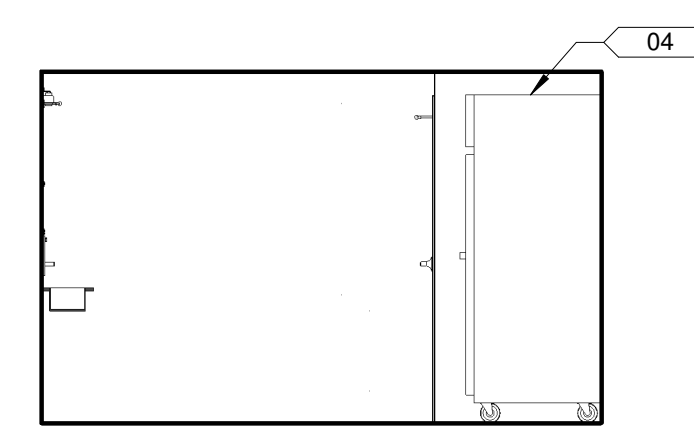

**D5 INT. ELEV - KITCHEN - 4**  
 1/4" = 1'-0"

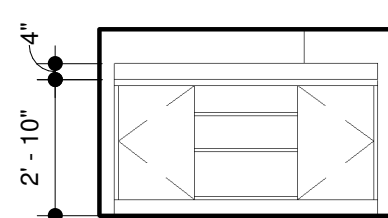

**C1 COFFEE STATION ELEVATION**  
 1/4" = 1'-0"

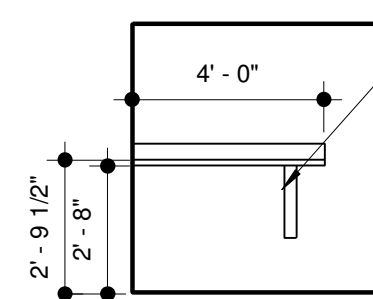

**C2 FOLDING COUNTER ELEVATION**  
 1/4" = 1'-0"

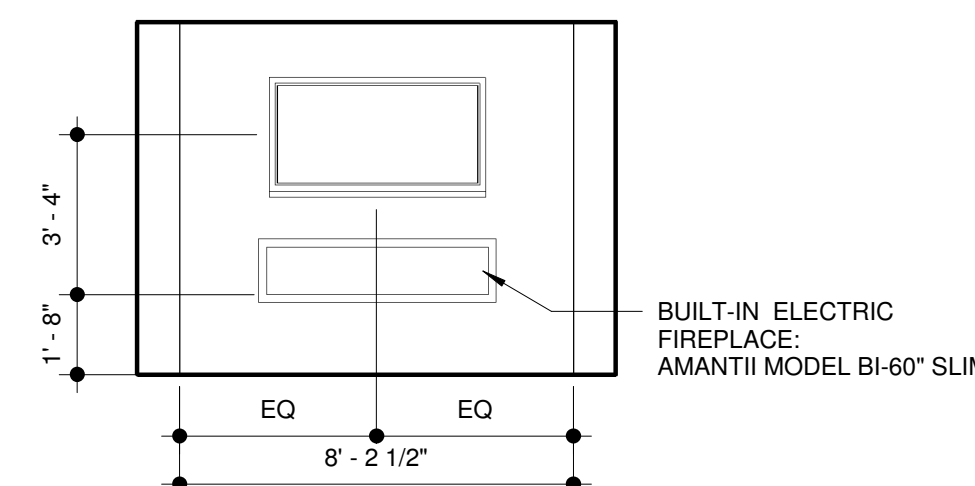

**C4 FIRE PLACE ELEVATION**  
 1/4" = 1'-0"

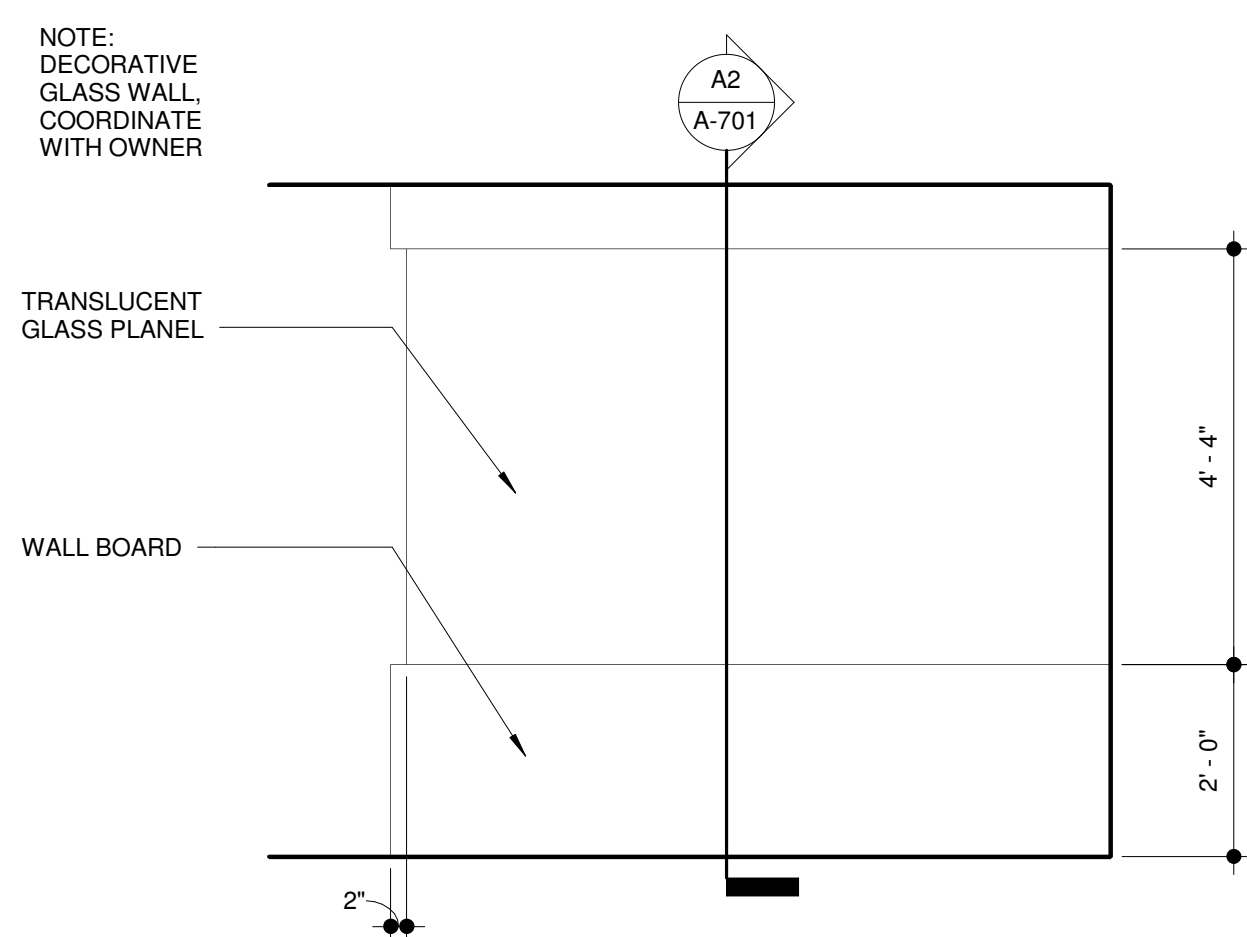

**A1 INT ELEV - GLASS PARTITION WALL**  
 1/2" = 1'-0"

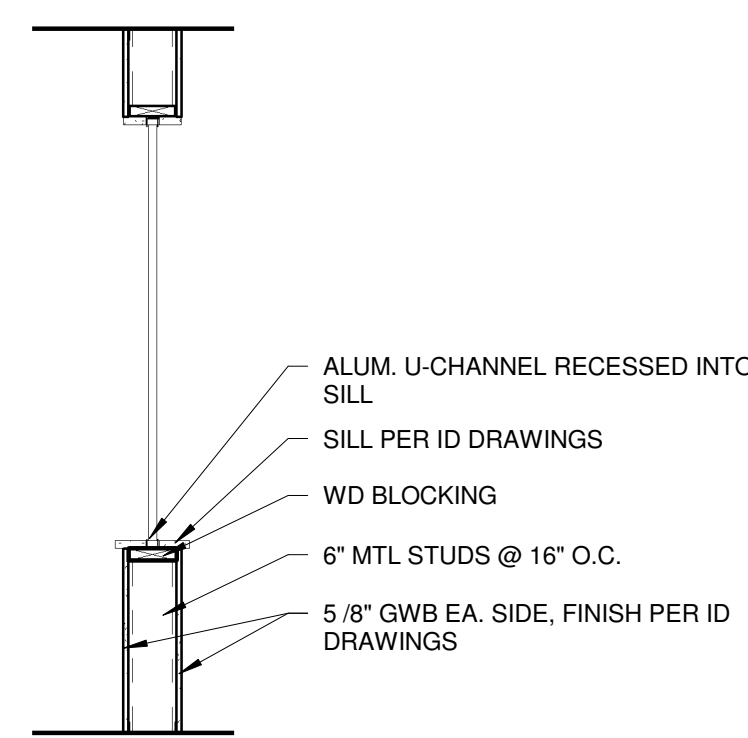

**A2 SECTION - GLASS PARTITION**  
 1/2" = 1'-0"

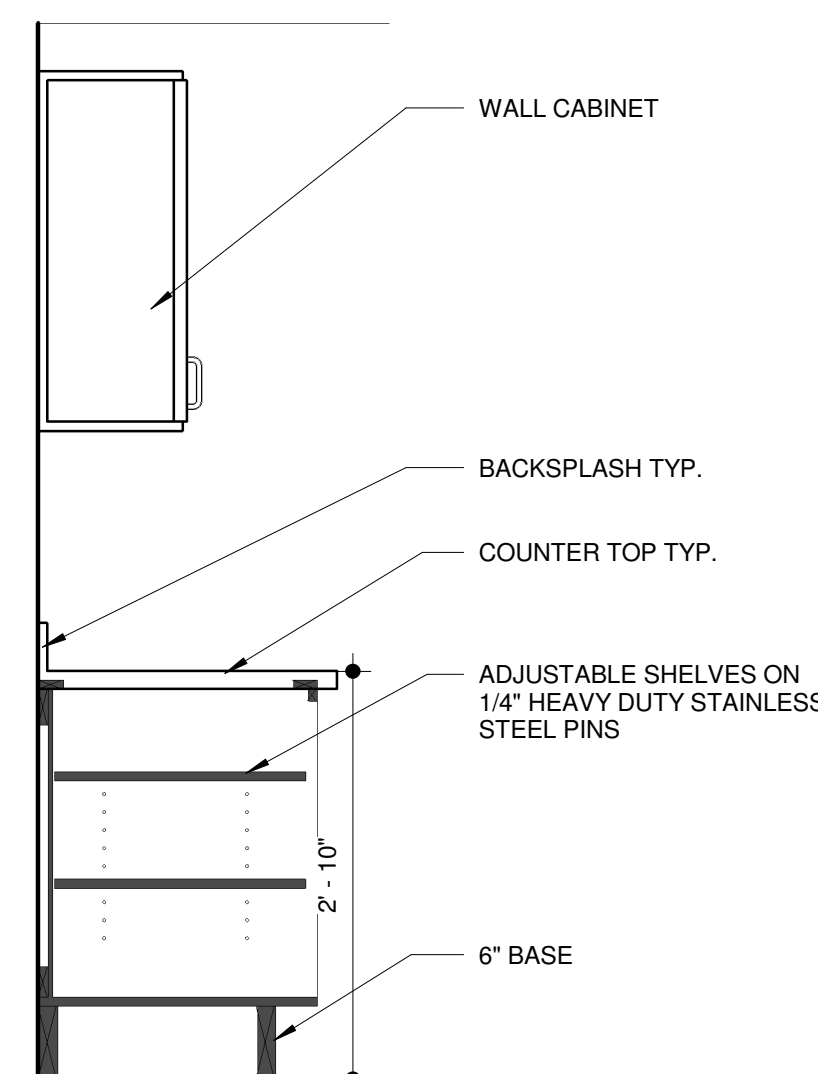

**A4 MILWORK SECTION - OPEN BASE CABINET**  
 3/4" = 1'-0"

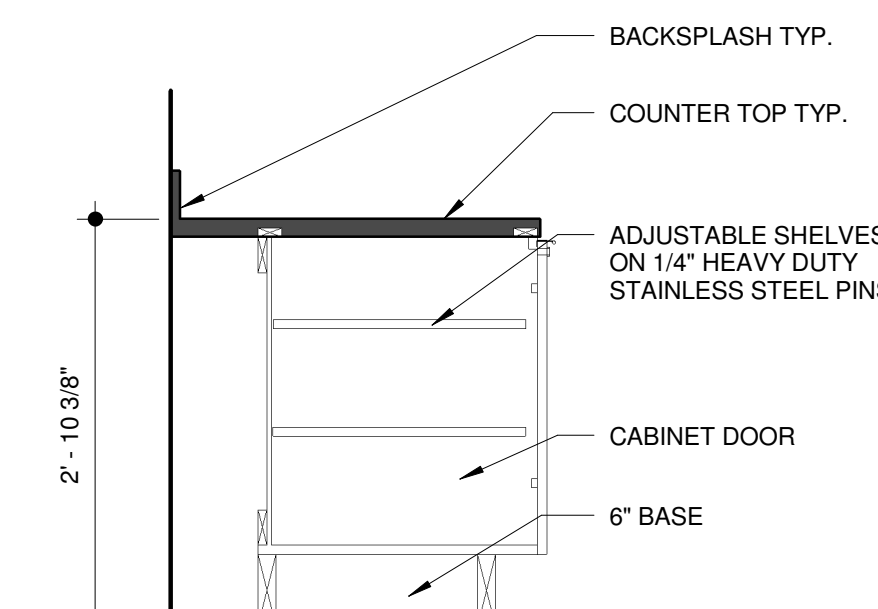

**A5 MILLWORK SECTION**  
 3/4" = 1'-0"