

**C1 INT ELEV - ENTRY WALL**  
 1/2" = 1'-0"

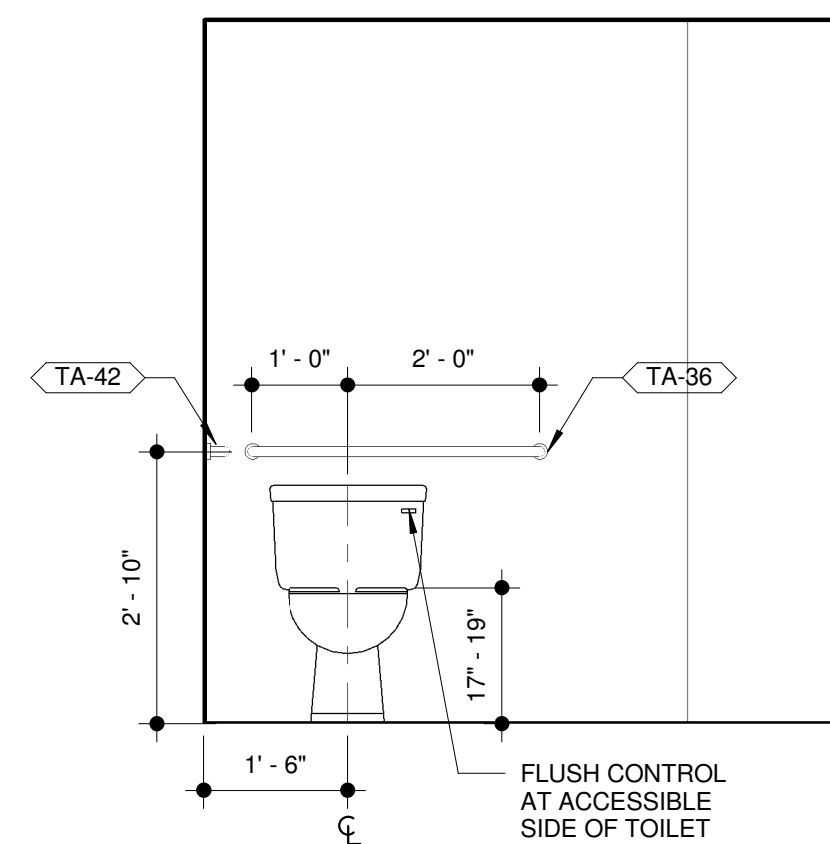

**C2 INT ELEV - TOILET WALL**  
 1/2" = 1'-0"

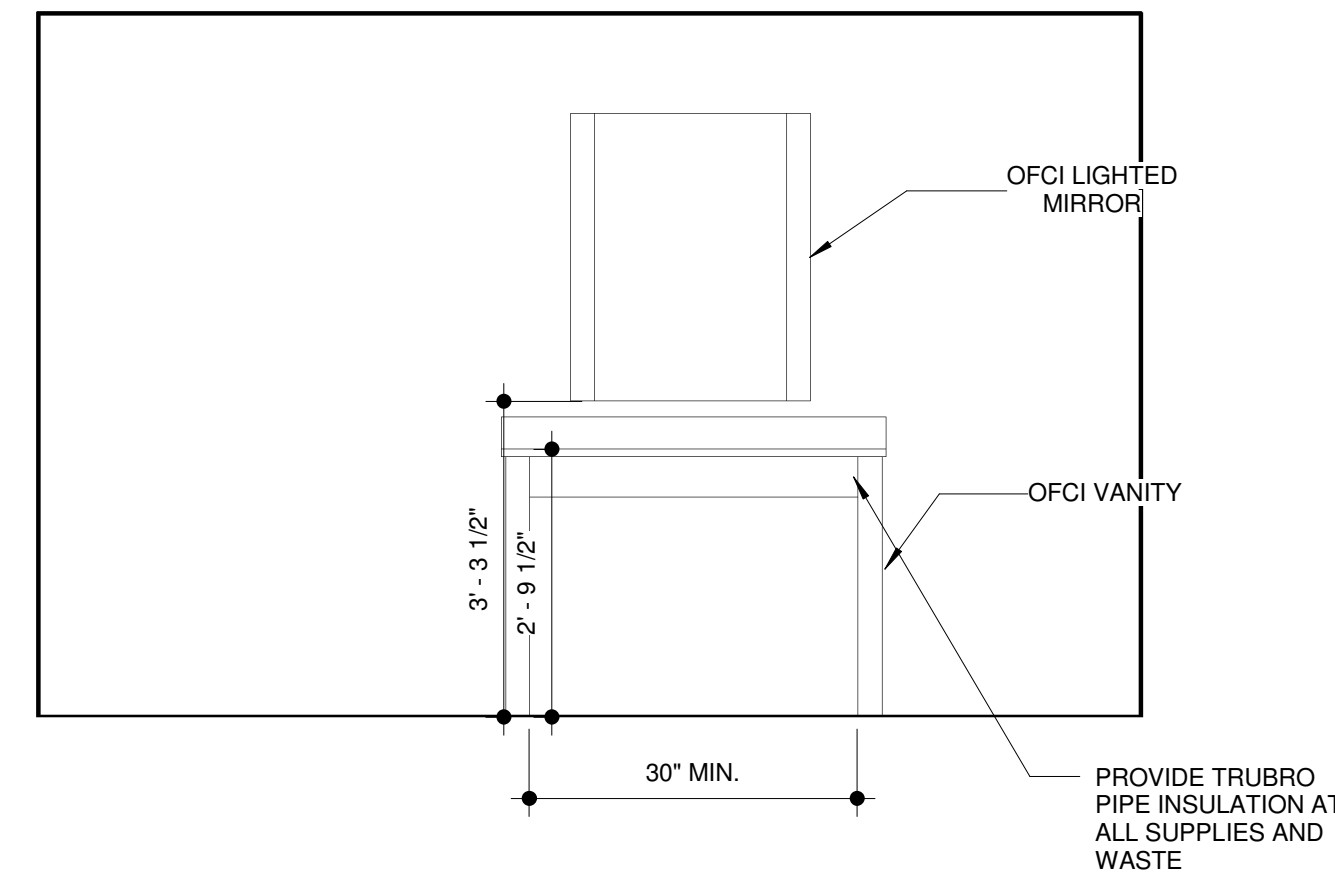

**C3 INT ELEV - VANITY WALL**  
 1/2" = 1'-0"

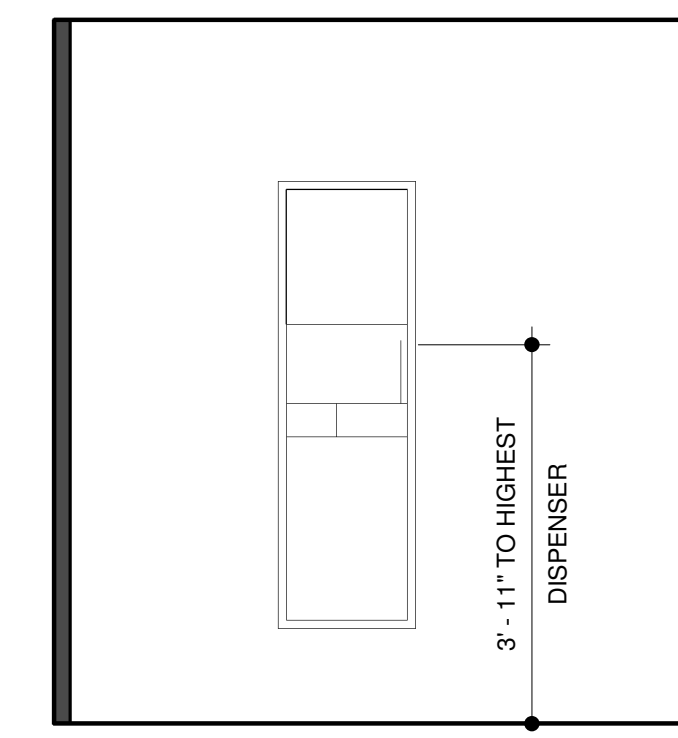

**C5 INT ELEV - TV WALL**  
 1/2" = 1'-0"

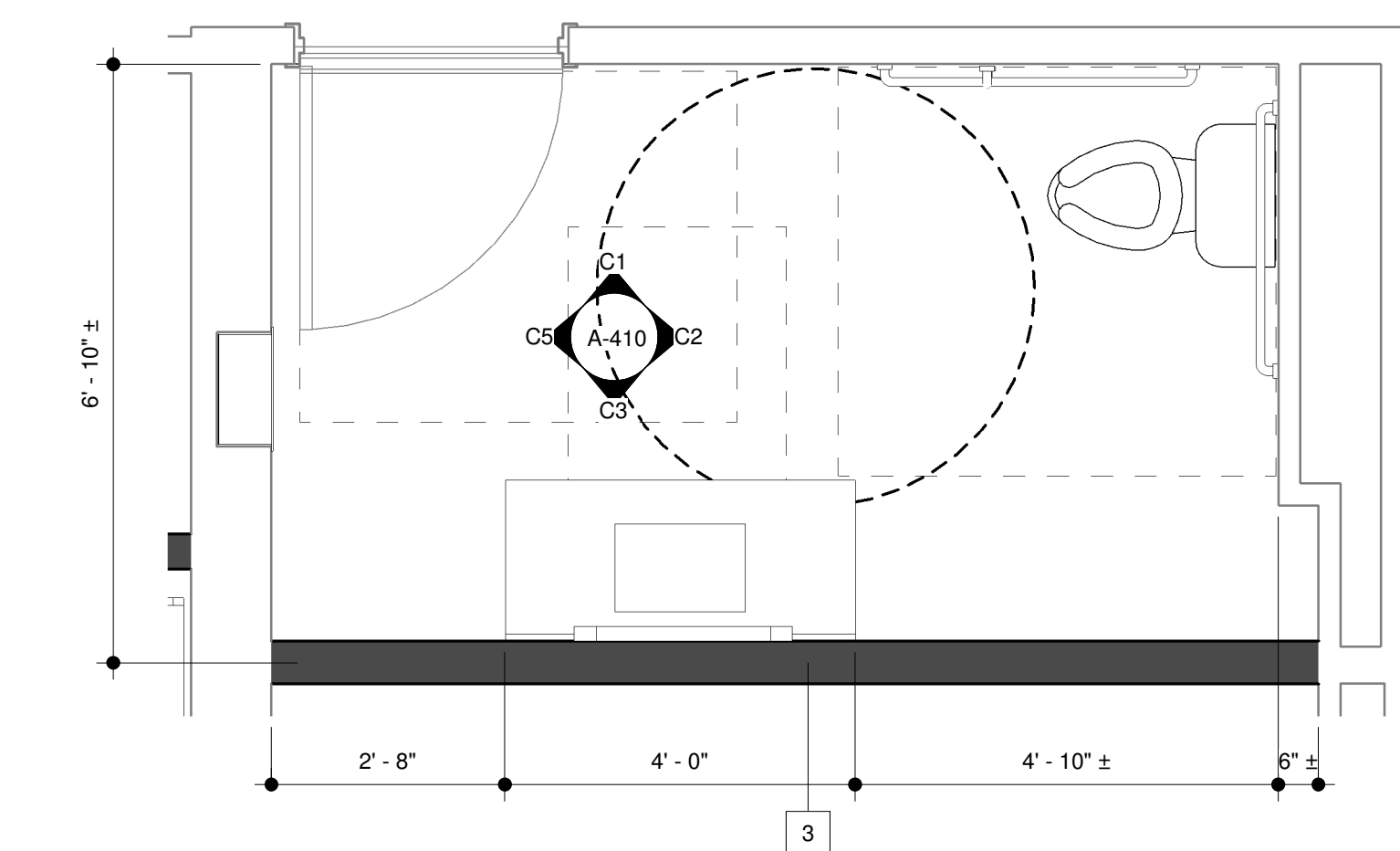

**A1 ENLARGED PUBLIC BATHROOM PLAN**  
 1/2" = 1'-0"

| TOILET ACCESSORY SCHEDULE |                             |
|---------------------------|-----------------------------|
| Type Mark                 | Description                 |
| TA-01                     | ADA SHOWER SEAT             |
| TA-02                     | ROBE HOOK                   |
| TA-03                     | TOWEL BAR - 18"             |
| TA-04                     | Toilet Paper Holder, Chrome |
| TA-05                     | 36" X 36" ADA SHOWER SEAT   |
| TA-12                     | GRAB BAR - 12"              |
| TA-18                     | GRAB BAR - 18"              |
| TA-24                     | GRAB BAR - 24"              |
| TA-36                     | GRAB BAR - 36"              |
| TA-42                     | GRAB BAR - 42"              |

**FINISHES NOTE:**  
 VERIFY ALL FINISHES WITH INTERIOR  
 FINISH SCHEDULES ON A-603 AND A-604