

| ELECTRICAL LOADS | | | | | |
|------------------|------------|------------------------|-----------------------------|----------------------------|----------------------------|
| CIRCUIT # | AMP RATING | DESCRIPTION | "A" LOAD (WATTS) | "B" LOAD (WATTS) | "C" LOAD (WATTS) |
| 1 | 20 | INTERIOR LIGHTS | 139.8 | - | - |
| 2 | 50 | RECEPTACLE | 4680 | - | - |
| 3 | 20 | EXTERIOR LIGHTS | - | 172 | - |
| 4 | 50 | RECEPTACLE | - | 4680 | - |
| 5 | 20 | SMOKE DETECTOR | 170 | - | 120 |
| 6 | 40 | HVAC UNIT #2 | - | - | 2010.66 |
| 8 | | | 2010.66 | - | - |
| 10 | | | - | 2010.66 | - |
| 7 | 40 | HVAC UNIT #1 | 2010.66 | - | - |
| 9 | | | - | 2010.66 | - |
| 11 | | | - | - | 2010.66 |
| 12 | 20 | RECEPTACLE | - | - | 1440 |
| 13 | 20 | SPARE | ** | - | - |
| 14 | 20 | SPARE | ** | - | - |
| 15 | 20 | SPARE | - | ** | - |
| 16 | 20 | SPARE | - | ** | - |
| 17 | 20 | EXTERIOR RECEPTACLE | - | - | 180 |
| 18 | 20 | TELCO BOARD RECEPTACLE | - | - | 360 |
| 19 | - | SPACE | ** | - | - |
| 20 | 20 | HYDROGEN SENSOR | ** | - | - |
| 21 | - | SPACE | - | ** | - |
| 22 | - | SPACE | - | ** | - |
| 23 | - | SPACE | - | - | ** |
| 24 | - | SPACE | - | - | ** |
| 25 | - | SPACE | ** | - | - |
| 26 | - | SPACE | ** | - | - |
| 27 | - | SPACE | - | ** | - |
| 28 | - | SPACE | - | ** | - |
| 29 | - | SPACE | - | - | ** |
| 30 | - | SPACE | - | - | ** |
| 31 | - | SPACE | ** | - | - |
| 32 | - | SPACE | ** | - | - |
| 33 | - | SPACE | - | ** | - |
| 34 | - | SPACE | - | ** | - |
| 35 | - | SPACE | - | - | ** |
| 36 | - | SPACE | - | - | ** |
| 37 | - | SPACE | ** | - | - |
| 38 | - | SPACE | ** | - | - |
| 39 | - | SPACE | - | ** | - |
| 40 | - | SPACE | - | ** | - |
| 41 | - | SPACE | - | - | ** |
| 42 | - | SPACE | - | - | ** |
| TOTAL | | | 9011.12 WATTS 75.1 AMPS | 8873.32 WATTS 73.9 AMPS | 6121.32 WATTS 51.0 AMPS |
| TOTAL | | | 24005.76 WATTS 66.6 AMPS | | |

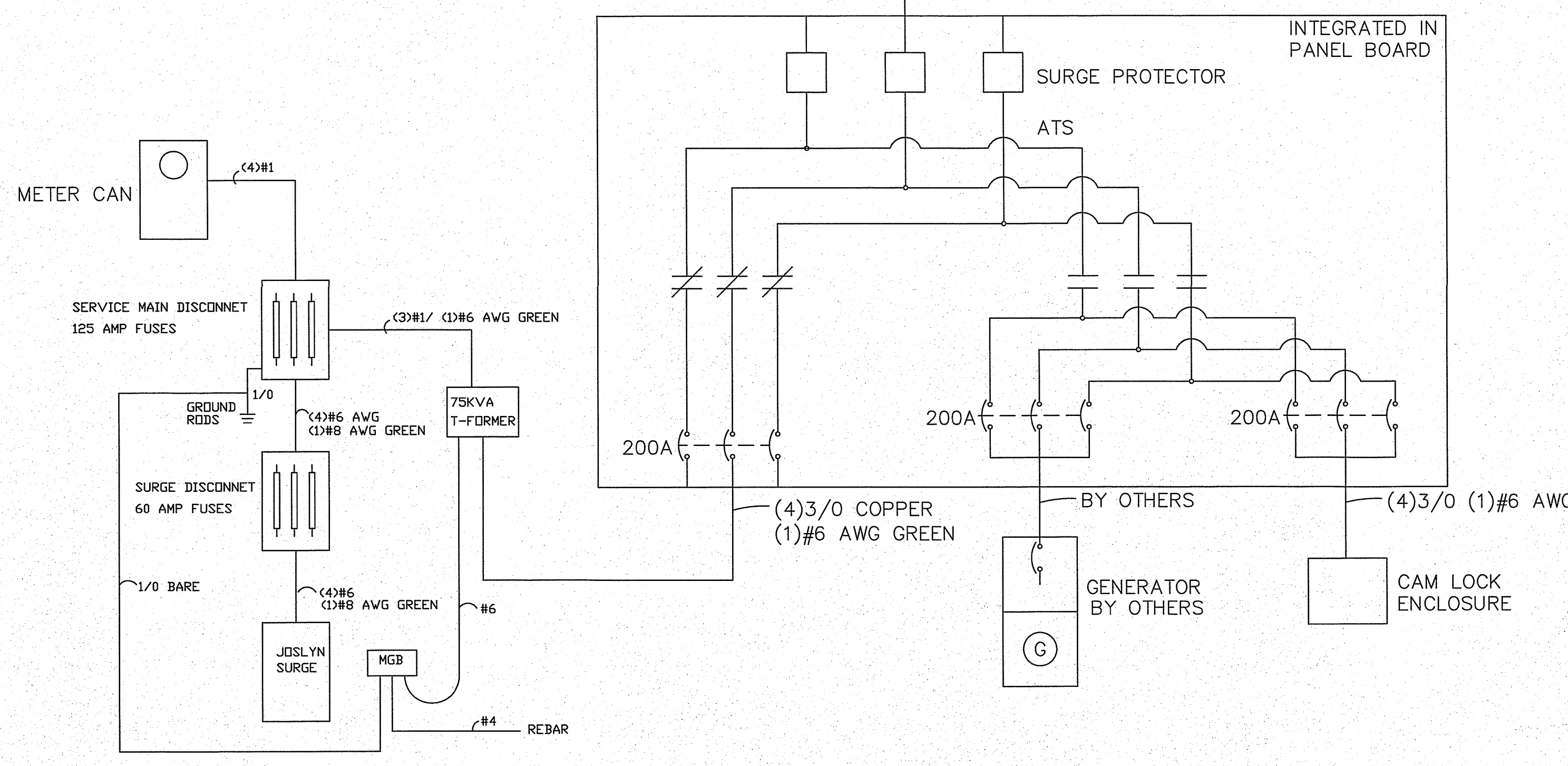

NOTES:
 1. ALL CONDUIT SHALL BE 3/4" EMT OR LARGER.
 2. ELECTRICAL WIRE INSULATION IS THHN / THWN.

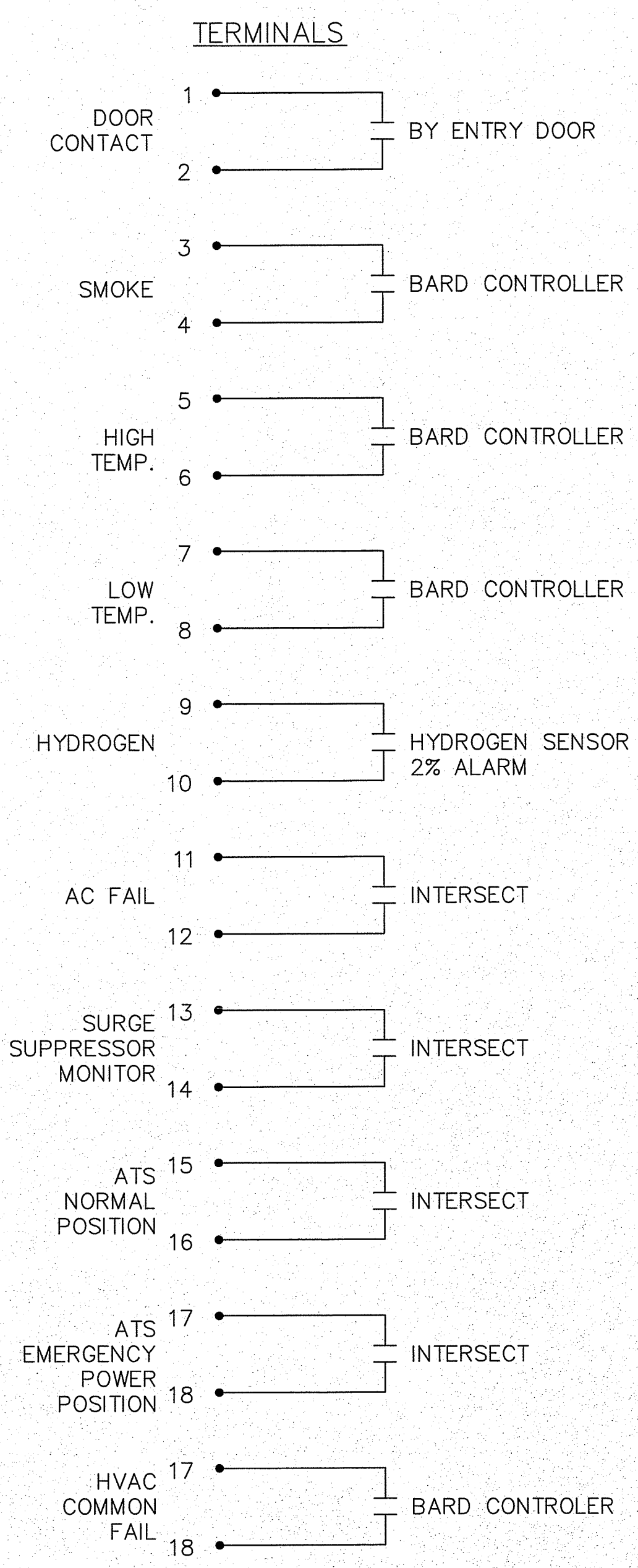
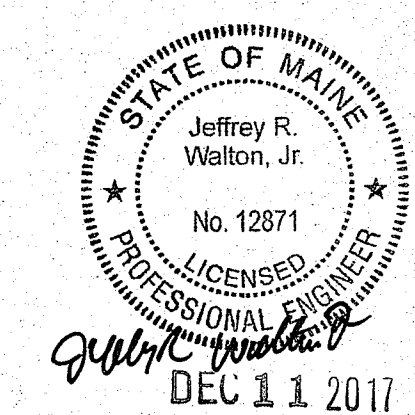

| ISSUE LOG | |
|-----------|------------------------|
| NUMBER | DESCRIPTION |
| 4 | |
| 3 | |
| 2 | |
| 1 | 11/9/17 REVISED PER JP |

UNITED
CONCRETE PRODUCTS
UNITED CONCRETE PRODUCTS INC.
 173 Church Street, Yalesville, CT 06492
 (800) 234-3119 Fax: (203) 265-4941

CUSTOMER: AHEARN HOLTZMAN, INC.
 JOB NAME: AT&T TELECOMMUNICATIONS HUT
 JOB LOCATION: PORTLAND, ME
 DWG TITLE: POWER DISTRIBUTION PANEL
 DRAFTER: JPR DATE: 10/27/17 CK BY: DATE:
 JOB NO: 9418 SCALE: NONE DRAWING NO: **EL-1**