

ELECTRICAL LOADS					
CIRCUIT #	AMP RATING	DESCRIPTION	"A" LOAD (WATTS)	"B" LOAD (WATTS)	"C" LOAD (WATTS)
1	20	INTERIOR LIGHTS	139.8	-	-
2	50	RECEPTACLE	4680	-	-
3	20	EXTERIOR LIGHTS	-	172	-
4	50	RECEPTACLE	-	4680	-
5	20	SMOKE DETECTOR	170	-	120
6			-	-	2010.66
8	40	HVAC UNIT #2	2010.66	-	-
10			-	2010.66	-
7			2010.66	-	-
9	40	HVAC UNIT #1	-	2010.66	-
11			-	-	2010.66
12	20	RECEPTACLE	-	-	1080
13	20	SPARE	**	-	-
14	20	SPARE	**	-	-
15	20	SPARE	-	**	-
16	20	SPARE	-	**	-
17	20	EXTERIOR RECEPTACLE	-	-	180
18	20	TELCO BOARD RECEPTACLE	-	-	360
19	-	SPACE	**	-	-
20	20	HYDROGEN SENSOR	**	-	-
21	-	SPACE	-	**	-
22	-	SPACE	-	**	-
23	-	SPACE	-	-	**
24	-	SPACE	-	-	**
25	-	SPACE	**	-	-
26	-	SPACE	**	-	-
27	-	SPACE	-	**	-
28	-	SPACE	-	**	-
29	-	SPACE	-	-	**
30	-	SPACE	-	-	**
31	-	SPACE	**	-	-
32	-	SPACE	**	-	-
33	-	SPACE	-	**	-
34	-	SPACE	-	**	-
35	-	SPACE	-	-	**
36	-	SPACE	-	-	**
37	-	SPACE	**	-	-
38	-	SPACE	**	-	-
39	-	SPACE	-	**	-
40	-	SPACE	-	**	-
41	-	SPACE	-	-	**
42	-	SPACE	-	-	**
TOTAL			9011.12 WATTS 75.1 AMPS	8873.32 WATTS 73.9 AMPS	5761.32 WATTS 48.0 AMPS
			23645.76 WATTS 65.6 AMPS		

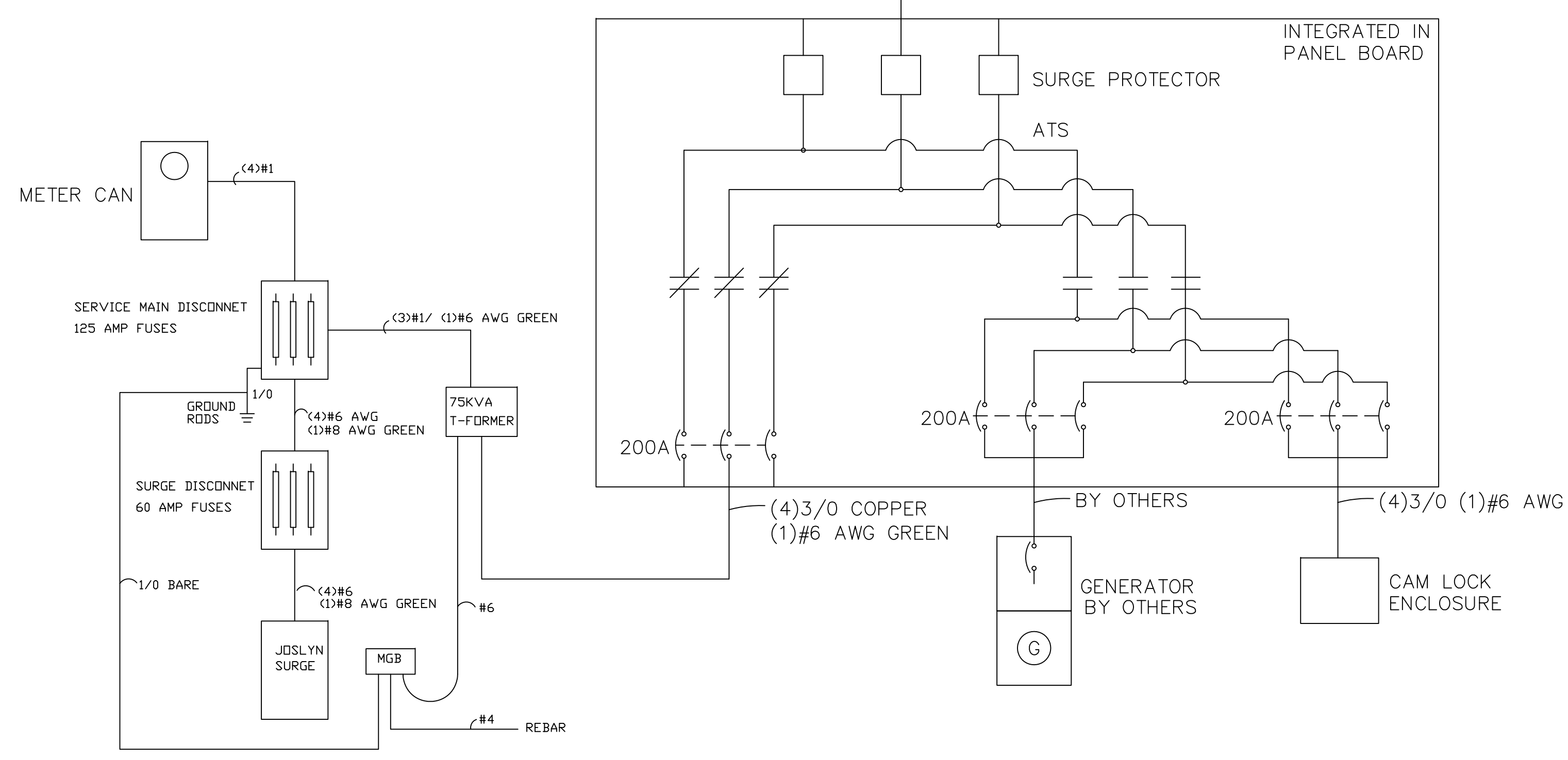
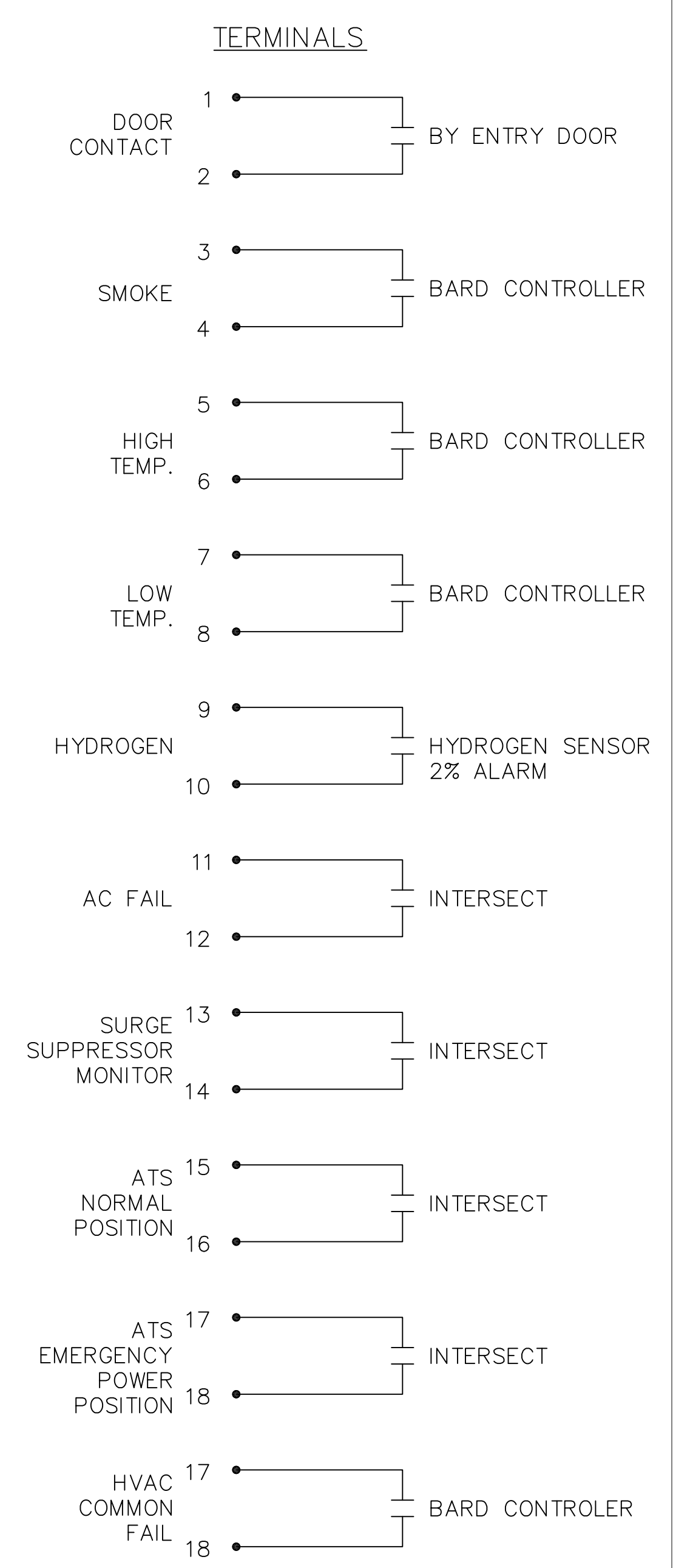

NOTES:
1. ALL CONDUIT SHALL BE 3/4" EMT OR LARGER.
2. ELECTRICAL WIRE INSULATION IS THHN / THWN.

ISSUE LOG		
NUMBER	DATE	DESCRIPTION
4		
3		
2		
1		

UNITED CONCRETE PRODUCTS INC.
173 Church Street, Yalesville, CT 06492
(800) 234-3119 Fax: (203) 265-4941

CUSTOMER: AHEARN HOLTZMAN, INC.
JOB NAME: AT&T TELECOMMUNICATIONS HUT
JOB LOCATION: PORTLAND, ME
DWG TITLE: POWER DISTRIBUTION PANEL
DRAFTER: JPR DATE: 10/27/17 CK BY: DATE:
JOB NO: 9418 SCALE: NONE DRAWING NO: EL-1