

PERMIT ISSUED

City of Portland, Maine - Building or Use Permit Application
389 Congress Street, 04101 Tel: (207) 874-8703, Fax: (207) 874-8716

Permit No: 03-1056	Date: SEP 08 2003	CBL: 063 G013001
-----------------------	----------------------	---------------------

Location of Construction: 145 Pine St	Owner Name: Altholz Eric D &	Owner Address: 147 Pine St	Phone: 207-774-4000
Business Name: n/a	Contractor Name: Taggart Construction	Contractor Address: PO Box 255 Freeport	Phone:
Lessee/Buyer's Name n/a	Phone: n/a	Permit Type: Alterations - Dwellings	Zone: R6

Past Use: Single Family	Proposed Use: Single Family / Masonry restoration, door and window replacements and replace 17' x 17' deck.	Permit Fee: \$426.00	Cost of Work: \$45,000.00	CEO District: 3
Proposed Project Description: Masonry restoration, door and window replacements and replace 17' x 17' deck.		FIRE DEPT: <input type="checkbox"/> Approved <input type="checkbox"/> Denied INSPECTION: Use Group: Type: R3 BOCA 1999 5B Signature: JMB 9/8/03 PEDESTRIAN ACTIVITIES DISTRICT (P.A.D.) Action: <input type="checkbox"/> Approved <input type="checkbox"/> Approved w/Conditions <input type="checkbox"/> Denied Signature: Date:		

Permit Taken By: gg	Date Applied For: 08/29/2003	Zoning Approval	
------------------------	---------------------------------	------------------------	--

1. This permit application does not preclude the Applicant(s) from meeting applicable State and Federal Rules. 2. Building permits do not include plumbing, septic or electrical work. 3. Building permits are void if work is not started within six (6) months of the date of issuance. False information may invalidate a building permit and stop all work..	Special Zone or Reviews <input type="checkbox"/> Shoreland <input checked="" type="checkbox"/> Wetland <i>approved</i> <input type="checkbox"/> Flood Zone <input type="checkbox"/> Subdivision <input type="checkbox"/> Site Plan Maj <input type="checkbox"/> Minor <input type="checkbox"/> MM <input type="checkbox"/> Date: <i>JMB 9/8/03</i>	Zoning Appeal <input type="checkbox"/> Variance <input type="checkbox"/> Miscellaneous <input type="checkbox"/> Conditional Use <input type="checkbox"/> Interpretation <input type="checkbox"/> Approved <input type="checkbox"/> Denied Date:	Historic Preservation <input type="checkbox"/> Not in District or Landmark <input type="checkbox"/> Does Not Require Review <input type="checkbox"/> Requires Review <input checked="" type="checkbox"/> Approved <input type="checkbox"/> Approved w/Conditions <input type="checkbox"/> Denied Date: <i>9/5/03</i> <i>As per H. F. Committee decision</i> <i>D. Andrew</i>
--	--	---	--

CERTIFICATION

I hereby certify that I am the owner of record of the named property, or that the proposed work is authorized by the owner of record and that I have been authorized by the owner to make this application as his authorized agent and I agree to conform to all applicable laws of this jurisdiction. In addition, if a permit for work described in the application is issued, I certify that the code official's authorized representative shall have the authority to enter all areas covered by such permit at any reasonable hour to enforce the provision of the code(s) applicable to such permit.

SIGNATURE OF APPLICANT	ADDRESS	DATE	PHONE
RESPONSIBLE PERSON IN CHARGE OF WORK, TITLE		DATE	PHONE

City of Portland, Maine - Building or Use Permit

389 Congress Street, 04101 Tel: (207) 874-8703, Fax: (207) 874-8716

Permit No: 03-1056	Date Applied For: 08/29/2003	CBL: 063 G013001
------------------------------	--	----------------------------

Location of Construction: 145 Pine St	Owner Name: Altholz Eric D &	Owner Address: 147 Pine St	Phone: 207-774-4000
Business Name: n/a	Contractor Name: Taggart Construction	Contractor Address: PO Box 255 Freeport	Phone:
Lessee/Buyer's Name: n/a	Phone: n/a	Permit Type: Alterations - Dwellings	

Proposed Use: Single Family / Masonry restoration, door and window replacements and replace 17' x 17' deck.	Proposed Project Description: Masonry restoration, door and window replacements and replace 17' x 17' deck.
---	---

Dept: Zoning **Status:** Approved **Reviewer:** Jeanine Bourke **Approval Date:** 09/04/2003
Note: **Ok to Issue:**
 1) This property shall remain a single family dwelling. Any change of use shall require a separate permit application for review and approval.

Dept: Building **Status:** Pending **Reviewer:** Jeanine Bourke **Approval Date:** 09/08/2003
Note: 9/4/03 left vm w/ Peter T. To call and clarify the garage floor and any existing framing **Ok to Issue:**
 1) Application approval based upon information provided by applicant. Any deviation from approved plans requires separate review and approval prior to work.

All Purpose Building Permit Application

If you or the property owner owes real estate or personal property taxes or user charges on any property within the City, payment arrangements must be made before permits of any kind are accepted.

Location/Address of Construction: <u>147 Pine Street Portland, ME</u>		
Total Square Footage of Proposed Structure		Square Footage of Lot
Tax Assessor's Chart, Block & Lot Chart# <u>063</u> Block# <u>6013</u> Lot#	Owner: <u>Eric Altholtz</u> <u>Mary McQuillen</u>	Telephone: <u>w 774-4000</u>
Lessee/Buyer's Name (if Applicable)	Applicant name, address & telephone: <u>Taggart Construction, Inc.</u> <u>P.O. Box 255</u> <u>Freeport, ME 04032</u>	Cost Of Work: \$ <u>45,000</u> Fee: \$ <u>126.00</u>
Current use: <u>Garage/Deck</u> <u>SIF</u>	DEPT. OF BUILDING INSPECTION CITY OF PORTLAND, ME RECEIVED <u>AUG 29 2003</u>	
If the location is currently vacant, what was prior use:		
Approximately how long has it been vacant:	Proposed use: <u>Garage/Deck</u> Project description: <u>Masonry Restoration, Door & Window Replacements</u> <u>Deck</u>	
Contractor's name, address & telephone: <u>Taggart Construction, Inc.</u>		
Who should we contact when the permit is ready: <u>Peter Taggart 865-2281 x5</u>		
Mailing address: <u>P.O. Box 255</u> <u>Freeport, ME 04032</u>		
We will contact you by phone when the permit is ready. You must come in and pick up the permit and review the requirements before starting any work, with a Plan Reviewer. A stop work order will be issued and a \$100.00 fee if any work starts before the permit is picked up. PHONE: <u>865-2281 x5</u>		

IF THE REQUIRED INFORMATION IS NOT INCLUDED IN THE SUBMISSIONS THE PERMIT WILL BE AUTOMATICALLY DENIED AT THE DISCRETION OF THE BUILDING/PLANNING DEPARTMENT, WE MAY REQUIRE ADDITIONAL INFORMATION IN ORDER TO APPROVE THIS PERMIT.

I hereby certify that I am the Owner of record of the named property, or that the owner of record authorizes the proposed work and that I have been authorized by the owner to make this application as his/her authorized agent. I agree to conform to all applicable laws of this jurisdiction. In addition, if a permit for work described in this application is issued, I certify that the Code Official's authorized representative shall have the authority to enter all areas covered by this permit at any reasonable hour to enforce the provisions of the codes applicable to this permit.

Signature of applicant: Peter Taggart Date: 8/28/03

This is NOT a permit, you may not commence ANY work until the permit is issued. If you are in a Historic District you may be subject to additional permitting and fees with the Planning Department on the 4th floor of City Hall

CITY OF PORTLAND, MAINE
HISTORIC PRESERVATION COMMITTEE

Stephen Sewall, Chair
Cordelia Pitman, Vice Chair
Edward Hobler
Susan Wroth
Camillo Breggia
Robert Parker
John Turk

August 7, 2003

Eric Altholz and Mary McQuillen
147 Pine Street
Portland, ME 04102

Re: Garage Alterations and Site Improvements

Dear Mr. Altholz and Ms. McQuillen:

On August 6, 2003, the City of Portland's Historic Preservation Committee voted 4-0 (Breggia, Pitman & Sewall absent) to approve your application for a Certificate of Appropriateness for garage alterations and site improvements at 147 Pine Street.

The approval was made subject to the following condition:

- That the final fence alignment and garage door trim detail be submitted to staff for review and approval.

All improvements shall be carried out as shown on the submitted plans and specifications submitted for the 8/6/03 public hearing and/or as described above. Changes to the approved plans and specifications and any additional work that may be undertaken must be reviewed and approved by this office prior to construction, alteration, or demolition. If, during the course of completing the approved work, conditions are encountered which prevent completing the approved work, or which require additional or alternative work, you must apply for and receive a Certificate of Appropriateness or Non-Applicability PRIOR to undertaking additional or alternative work.

This Certificate is granted upon condition that the work authorized herein is commenced within twelve (12) months after the date of issuance. If the work authorized by this Certificate is not commenced within twelve (12) months after the date of issuance or if such work is suspended in significant part for a period of one year after the time the work is commenced, such Certificate shall expire and be of no further effect; provided that, for cause, one or more extensions of time for periods not exceeding ninety (90) days each may be allowed in writing by the Department.

Sincerely,

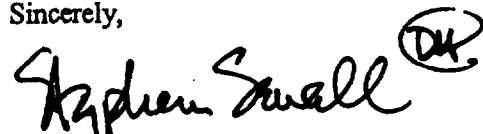

Stephen Sewall, Chairman
Historic Preservation Committee

cc: Paul Attardo, Van Dam Architecture & Design
Approval Letter File
Building Inspections

TAGGART CONSTRUCTION INC.

207 / 865 - 2281

P.O. Box 255 ♦ Freeport, Maine 04032

Fax Memo / Transmittal

DATE: 4 SEPTEMBER, 2003 **FAX:** 874-8716**TO:** Jennie Bourke **VOICE:**

FROM: Peter Taggart
VOICE: 207 / 865-2281 **FAX:** 865-2183**RE:** ~~174~~ Pine Street **OF PAGES :** 4
145

Jennie,

Here is the engineering specifications for the Altholz garage ceiling from Becker Engineering.

Please let me know if you need additional information.

Thank you,

Peter Taggart

Environment & Inhabitant Friendly ♦ Building ♦ Renovating ♦ Consulting

BECKER

structural engineers, inc.

19 Commercial Street, Portland, ME 04101-4701
Tel. 207-879-1838 ■ Fax 207-879-1822

Project ALHOLZ GARAGE

W.O. _____ Sheet _____ Of _____

Calculated By: PHB Date 01.03

Checked By: _____ Date _____

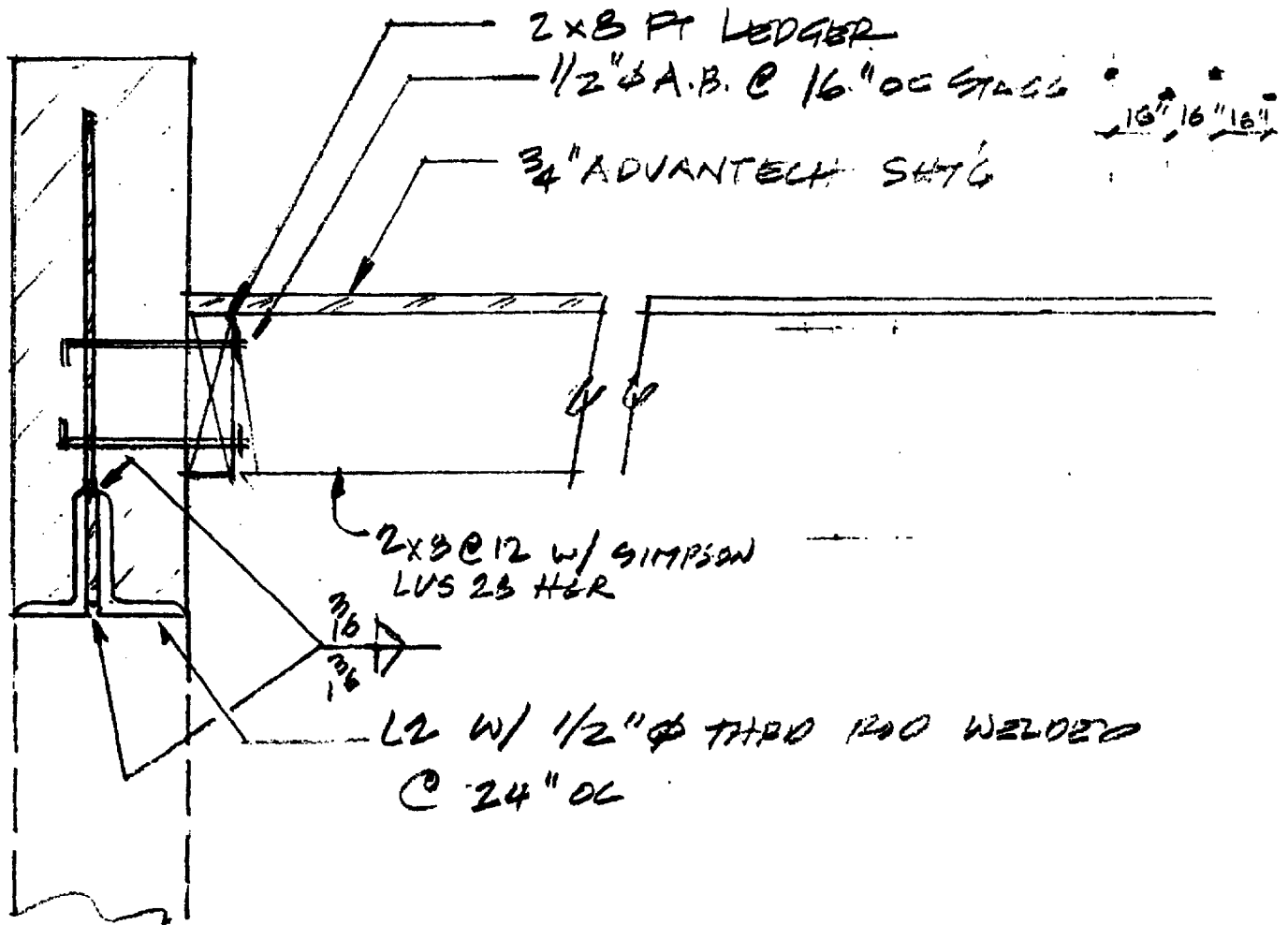

SECTION 1

BECKER

structural engineers, inc.

19 Commercial Street, Portland, ME 04101-4701
Tel. 207-879-1838 ■ Fax 207-879-1822

Project ALTHOLTZ GARAGE

W.O. _____ Sheet _____ Of _____

Calculated By: PHB Date 6-1-03

Checked By: _____ Date _____

#4 VERT REBAR @ 32" O.C.
EPOXY REBAR TO EXIST MASONRY
USING HILTI HIT
ADHESIVE W/ SCREEN TUBES.
EMBED 6"

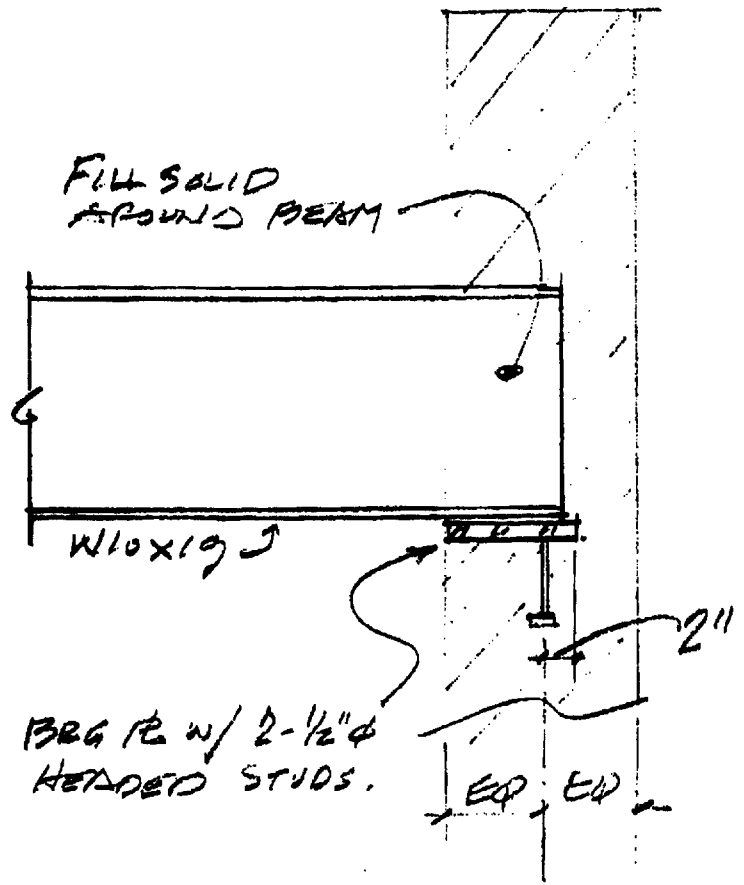
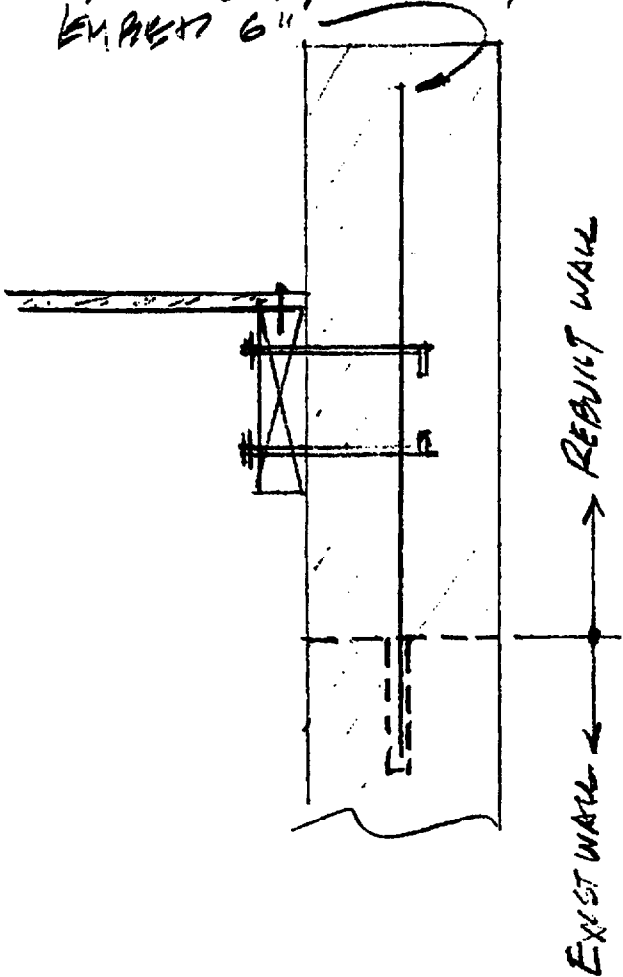

BECKER
 structural engineers, Inc
 19 Commercial Street Portland, ME 04101
 Ph: 207.879.1838 Fax: 207.879.1822

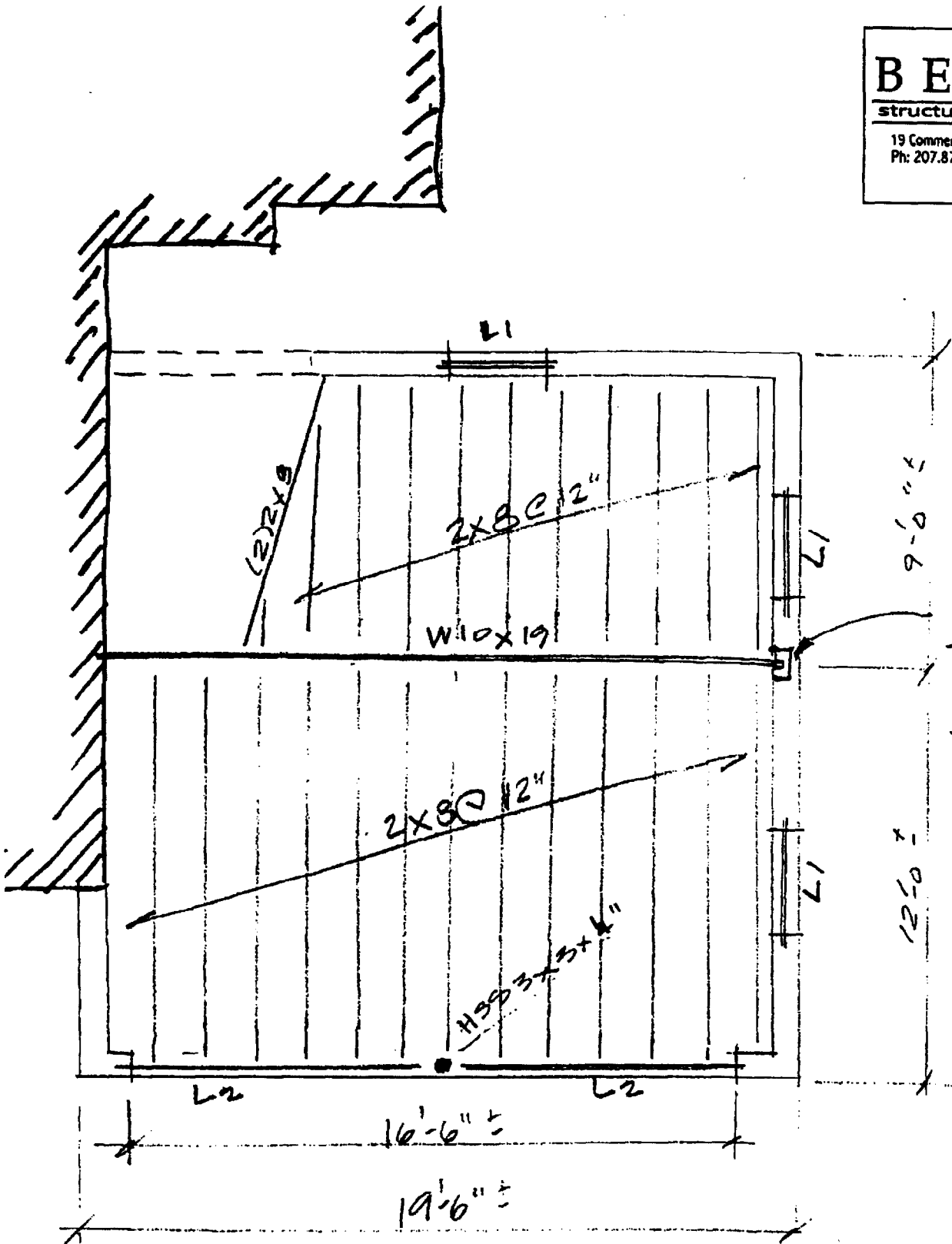

LINTEL SCHEDULE	
L1	1L 3 1/2 x 3 1/2 x 5/16 HD GALV
L2	1L 6 x 3 1/2 x 3/8 HD GALV

ALTHOLTZ GARAGE

DISPLAY THIS CARD ON PRINCIPAL FRONTAGE OF WORK
CITY OF PORTLAND

BUILDING INSPECTION

PERMIT ISSUED

Permit Number: 031056
SEP 08 2003

Please Read Application And Notes, if Any, Attached

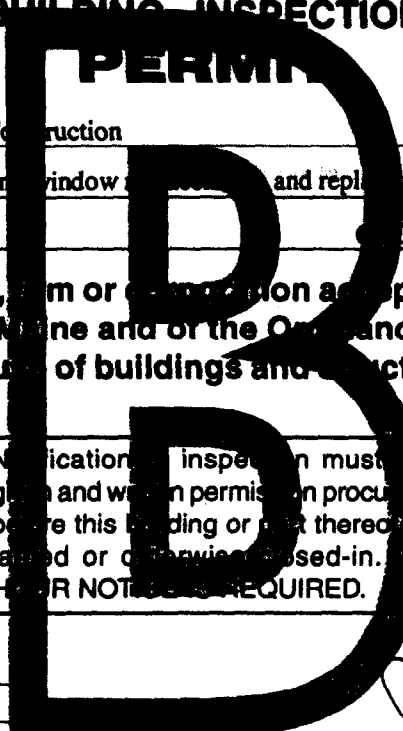

This is to certify that Alholz Eric D &/Taggart Construction

has permission to Masonry restoration, door and window work and repl. 17' x 17' deck.

AT 145 Pine St 063 G013001

provided that the person or persons, firm or corporation accepting this permit shall comply with all of the provisions of the Statutes of Maine and of the Ordinances of the City of Portland regulating the construction, maintenance and use of buildings and structures, and of the application on file in this department.

Apply to Public Works for street line and grade if nature of work requires such information.

Notification of inspection must be given and written permission procured before this building or part thereof is occupied or services used-in. HOUR NOTICES REQUIRED.

A certificate of occupancy must be procured by owner before this building or part thereof is occupied.

OTHER REQUIRED APPROVALS

Fire Dept. _____

Health Dept. _____

Appeal Board _____

Other _____
Department Name

Janie Bouke 9/8/03
Director - Building & Inspection Services

PENALTY FOR REMOVING THIS CARD