

DISPLAY THIS CARD ON PRINCIPAL FRONTAGE OF WORK

CITY OF PORTLAND

BUILDING DEPARTMENT

PERMIT

DEPT. OF BUILDING INSPECTION
CITY OF PORTLAND, ME

Permit Number: 070830

JUL 25 2007

RECEIVED

Please Read
Application And
Notes, If Any,
Attached

This is to certify that VAUGHAN STREET REAL ESTATE ASSOCIATES / Seacoast Security

has permission to Upgrade fire alarm system

AT 229 VAUGHAN ST 063 C004001

provided that the person or persons, firm or corporation accepting this permit shall comply with all of the provisions of the Statutes of Maine and of the Ordinances of the City of Portland regulating the construction, maintenance and use of buildings and structures, and of the application on file in this department.

Apply to Public Works for street line and grade if nature of work requires such information.

Notification of inspection must be given and written permission procured before this building or part thereof is altered or closed-in. 48 HOUR NOTICE IS REQUIRED.

A certificate of occupancy must be procured by owner before this building or part thereof is occupied.

OTHER REQUIRED APPROVALS

Fire Dept. Greg Carr

Health Dept. _____

Appeal Board _____

Other _____
Department Name

[Handwritten Signature]
7/25/07
Director - Building & Inspection Services

PENALTY FOR REMOVING THIS CARD

City of Portland, Maine - Building or Use Permit Application

389 Congress Street, 04101 Tel: (207) 874-8703, Fax: (207) 874-8716

Permit No: 07-0830	Issue Date:	CBL: 063 C004001
-----------------------	-------------	---------------------

Location of Construction: 229 VAUGHAN ST	Owner Name: VAUGHAN STREET REALTY AS	Owner Address: 233 VAUGHAN ST	Phone:
Business Name:	Contractor Name: Seacoast Security	Contractor Address: 4 Summer Street Freeport	Phone 2078650394
Lessee/Buyer's Name	Phone:	Permit Type: Fire Alarm System	Zone: R-6

Past Use: Medical Office	Proposed Use: Medical Office - Upgrade fire alarm system	Permit Fee: \$110.00	Cost of Work: \$9,000.00	CEO District: 2
		FIRE DEPT: <input checked="" type="checkbox"/> Approved <input type="checkbox"/> Denied	INSPECTION: Use Group: U Type: NFPA	

Proposed Project Description: Upgrade fire alarm system	Signature: <i>[Handwritten Signature]</i>	Signature: <i>[Handwritten Signature]</i>
PEDESTRIAN ACTIVITIES DISTRICT (P.A.D.)		
Action: <input type="checkbox"/> Approved <input type="checkbox"/> Approved w/Conditions <input type="checkbox"/> Denied		
Signature:		Date:

Permit Taken By: ldobson	Date Applied For: 07/09/2007	Zoning Approval		
-----------------------------	---------------------------------	------------------------	--	--

- This permit application does not preclude the Applicant(s) from meeting applicable State and Federal Rules.
- Building permits do not include plumbing, septic or electrical work.
- Building permits are void if work is not started within six (6) months of the date of issuance. False information may invalidate a building permit and stop all work..

Special Zone or Reviews <input type="checkbox"/> Shoreland <input type="checkbox"/> Wetland <input type="checkbox"/> Flood Zone <input type="checkbox"/> Subdivision <input type="checkbox"/> Site Plan Maj <input type="checkbox"/> Minor <input checked="" type="checkbox"/> MM <input type="checkbox"/> Date: <i>7/11/07</i>	Zoning Appeal <input type="checkbox"/> Variance <input type="checkbox"/> Miscellaneous <input type="checkbox"/> Conditional Use <input type="checkbox"/> Interpretation <input type="checkbox"/> Approved <input type="checkbox"/> Denied Date:	Historic Preservation <input type="checkbox"/> Not in District or Landmark <input type="checkbox"/> Does Not Require Review <input type="checkbox"/> Requires Review <input type="checkbox"/> Approved <input type="checkbox"/> Approved w/Conditions <input type="checkbox"/> Denied Date: <i>request</i>
--	--	---

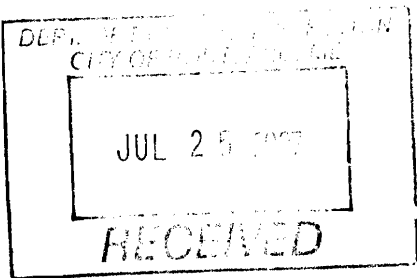

Any exterior work requires separate review & approval

CERTIFICATION

I hereby certify that I am the owner of record of the named property, or that the proposed work is authorized by the owner of record and that I have been authorized by the owner to make this application as his authorized agent and I agree to conform to all applicable laws of this jurisdiction. In addition, if a permit for work described in the application is issued, I certify that the code official's authorized representative shall have the authority to enter all areas covered by such permit at any reasonable hour to enforce the provision of the code(s) applicable to such permit.

SIGNATURE OF APPLICANT	ADDRESS	DATE	PHONE
RESPONSIBLE PERSON IN CHARGE OF WORK, TITLE		DATE	PHONE

City of Portland, Maine - Building or Use Permit

389 Congress Street, 04101 Tel: (207) 874-8703, Fax: (207) 874-8716

Permit No: 07-0830	Date Applied For: 07/09/2007	CBL: 063 C004001
------------------------------	--	----------------------------

Location of Construction: 229 VAUGHAN ST	Owner Name: VAUGHAN STREET REALTY AS	Owner Address: 233 VAUGHAN ST	Phone:
Business Name:	Contractor Name: Seacoast Security	Contractor Address: 4 Summer Street Freeport	Phone (207) 865-0394
Lessee/Buyer's Name	Phone:	Permit Type: Fire Alarm System	

Proposed Use: Medical Office - Upgrade fire alarm system	Proposed Project Description: Upgrade fire alarm system
--	---

Dept: Zoning **Status:** Approved **Reviewer:** Marge Schmuckal **Approval Date:** 07/11/2007
Note: **Ok to Issue:**

Dept: Building **Status:** Approved **Reviewer:** Tammy Munson **Approval Date:** 07/25/2007
Note: **Ok to Issue:**

Dept: Fire **Status:** Approved with Conditions **Reviewer:** Capt Greg Cass **Approval Date:** 07/11/2007
Note: **Ok to Issue:**

- 1) Installation of a Fire Alarm system requires a Knox Box to be installed per city ordinance
- 2) The fire alarm system shall comply with NFPA 72

Comments:

7/11/2007-mes: 8 medical offices were approved in this building by the ZBA under a variance appeal on 5/12/66.



General Building Permit Application

If you or the property owner owes real estate or personal property taxes or user charges on any property within the City, payment arrangements must be made before permits of any kind are accepted.

Location/Address of Construction: <u>229 Vaughn St</u>		
Total Square Footage of Proposed Structure		Square Footage of Lot
Tax Assessor's Chart, Block & Lot Chart# <u>63</u> Block# <u>C</u> Lot# <u>4</u>	Owner: <u>MMC Property, 175 Mt Pleasant St, Portland, ME 04102</u>	Telephone: <u>667-8065</u>
Lessee/Buyer's Name (If Applicable)	Applicant name, address & telephone: <u>Seacoast Security 4 Summer St Freeport, ME 04032</u>	Cost Of Work: \$ <u>9000</u> Fee: \$ <u>110.00</u> C of O Fee: \$ _____
Current legal use (i.e. single family) <u>N/A</u> If vacant, what was the previous use? <u>medical office</u> Proposed Specific use: _____ Is property part of a subdivision? <u>No</u> If yes, please name _____ Project description: <u>new upgrade fire system - Building</u>		
Contractor's name, address & telephone: Who should we contact when the permit is ready: <u>Jack Darling</u> Mailing address: <u>4 Summer St</u> Phone: <u>207-877-0794</u> <u>P.O. Box K Freeport ME 04032</u>		

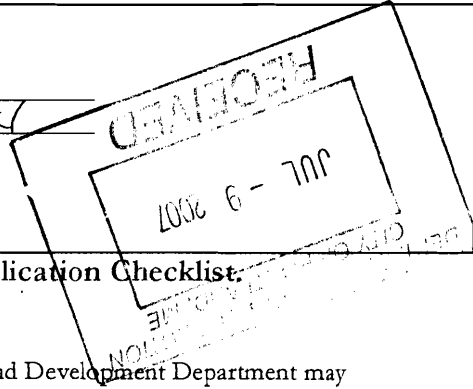

Please submit all of the information outlined in the Commercial Application Checklist. Failure to do so will result in the automatic denial of your permit.

In order to be sure the City fully understands the full scope of the project, the Planning and Development Department may request additional information prior to the issuance of a permit. For further information or to download copies of this form and other applications visit the Inspections Division on-line at www.portlandmaine.gov, or stop by the Inspections Division office, room 315 City Hall or call 874-8703.

I hereby certify that I am the Owner of record of the named property, or that the owner of record authorizes the proposed work and that I have been authorized by the owner to make this application as his/her authorized agent. I agree to conform to all applicable laws of this jurisdiction. In addition, if a permit for work described in this application is issued, I certify that the Code Official's authorized representative shall have the authority to enter all areas covered by this permit at any reasonable hour to enforce the provisions of the codes applicable to this permit.

Signature of applicant; <u>[Signature]</u>	Date: <u>07-09-07</u>
--	-----------------------

This is not a permit; you may not commence ANY work until the permit is issued.

229 Vaughan St
Portland Me.

Riser Diagram By Seacoast Security Freeport

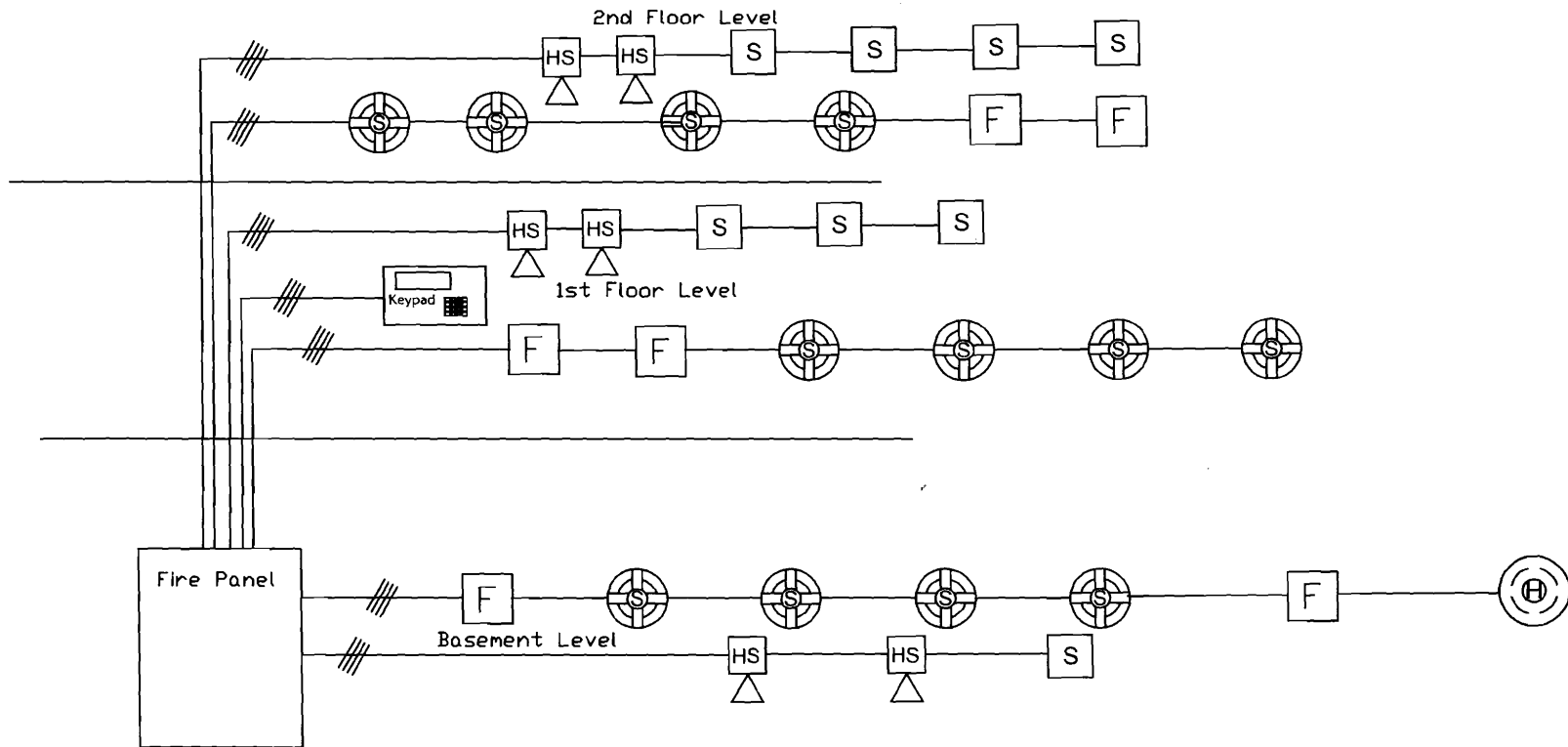

BASEMENT

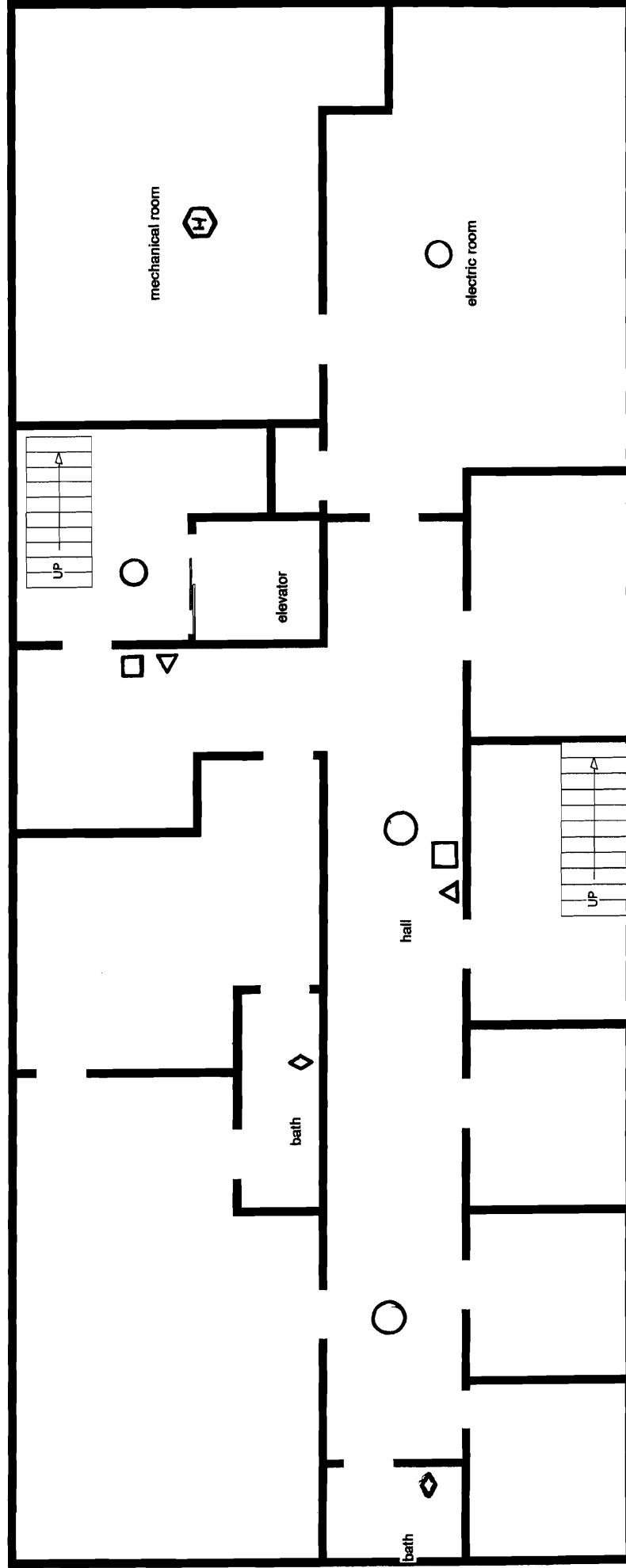

FIRST FLOOR

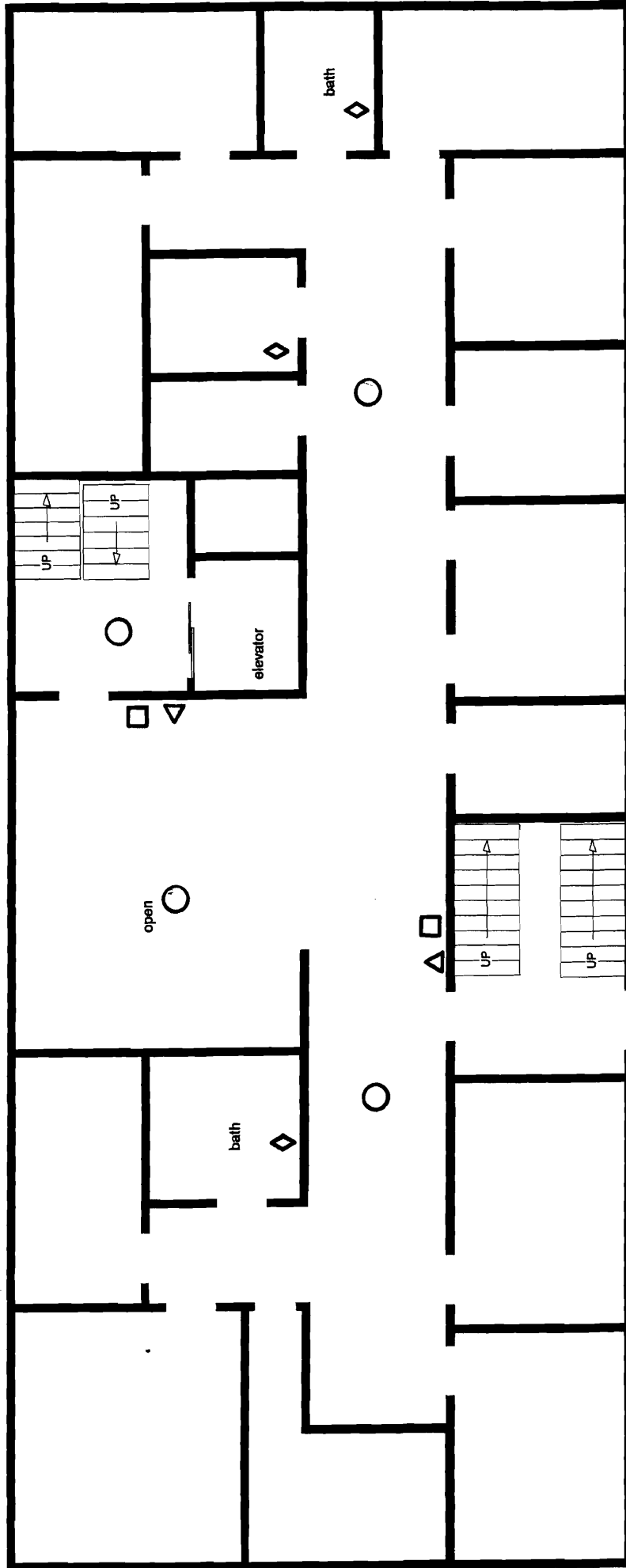

SECOND FLOOR

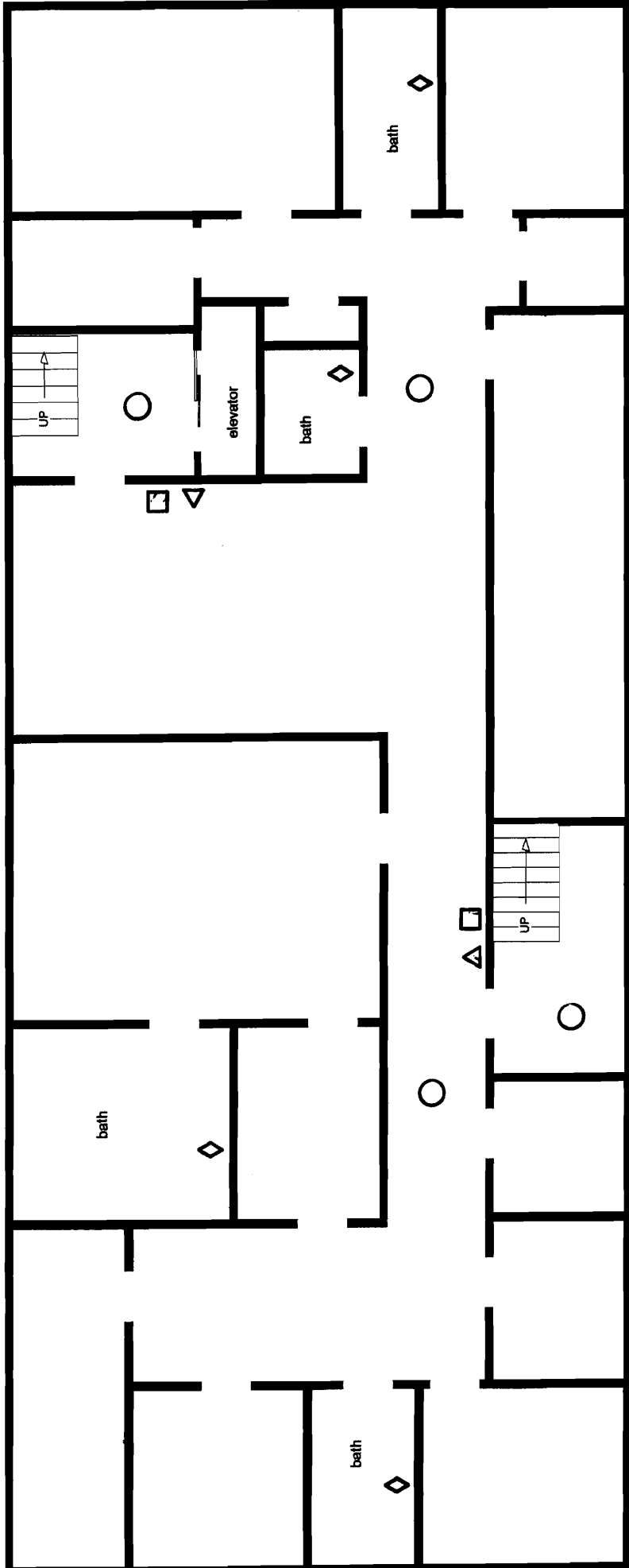

Please call 874-8703 or 874-8693 to schedule your inspections as agreed upon

Permits expire in 6 months, if the project is not started or ceases for 6 months.

The Owner or their designee is required to notify the inspections office for the following inspections and provide adequate notice. Notice must be called in 48-72 hours in advance in order to schedule an inspection:

By initializing at each inspection time, you are agreeing that you understand the inspection procedure and additional fees from a "Stop Work Order" and "Stop Work Order Release" will be incurred if the procedure is not followed as stated below.

A Pre-construction Meeting will take place upon receipt of your building permit.

- Footing/Building Location Inspection: Prior to pouring concrete
- Re-Bar Schedule Inspection: Prior to pouring concrete
- Foundation Inspection: Prior to placing ANY backfill
- Framing/Rough Plumbing/Electrical: Prior to any insulating or drywalling
- Final/Certificate of Occupancy: Prior to any occupancy of the structure or use. ~~NOTE: There is a \$75.00 fee per inspection at this point.~~

Certificate of Occupancy is not required for certain projects. Your inspector can advise you if your project requires a Certificate of Occupancy. All projects DO require a final inspection.

~~X~~ If any of the inspections do not occur, the project cannot go on to the next phase, REGARDLESS OF THE NOTICE OR CIRCUMSTANCES.

~~N/A~~ CERTIFICATE OF OCCUPANCIES MUST BE ISSUED AND PAID FOR, BEFORE THE SPACE MAY BE OCCUPIED

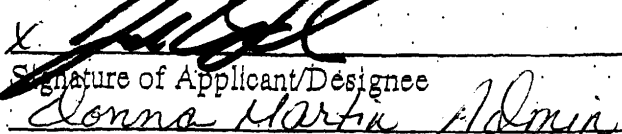
~~X~~ 
Signature of Applicant/Designee
Donna Martin Admin
Signature of Inspections Official

07-25-07
Date
07-25-07
Date

CBL: 63 C004 Building Permit #: 07 0830

ELECTRICAL PERMIT

City of Portland, Me.



To the Chief Electrical Inspector, Portland Maine:
 The undersigned hereby applies for a permit to make electrical installations
 in accordance with the laws of Maine, the City of Portland Electrical Ordinance,
 National Electrical Code and the following specifications:

Date _____
 Permit # 2004507
 CBL# 63 C 4

LOCATION: 229 Vaughn St METER MAKE & # _____
 CMP ACCOUNT # _____ OWNER MMC Property Mgmt
 TENANT _____ PHONE # (207) 662-8065

						TOTAL EACH FEE		
OUTLETS	Receptacles	Switches	Smoke Detector			.20		
FIXTURES	Incandescent	Fluorescent	Strips			.20		
SERVICES	Overhead	Underground	TTL AMPS <800			15.00		
	Overhead	Underground	>800			25.00		
Temporary Service	Overhead	Underground	TTL AMPS			25.00		
						25.00		
METERS	(number of)					1.00		
MOTORS	(number of)					2.00		
RESID/COM	Electric units					1.00		
HEATING	oil/gas units	Interior	Exterior			5.00		
APPLIANCES	Ranges	Cook Tops	Wall Ovens			2.00		
	Insta-Hot	Water heaters	Fans			2.00		
	Dryers	Disposals	Dishwasher			2.00		
	Compactors	Spa	Washing Machine			2.00		
	Others (denote)					2.00		
	MISC. (number of)	Air Cond/win					3.00	
		Air Cond/cent			Pools		10.00	
HVAC		EMS	Thermostat			5.00		
Signs						10.00		
Alarms/res						5.00		
Alarms/com						15.00		
Heavy Duty(CRKT)						2.00		
Circus/Carnv						25.00		
Alterations						5.00		
Fire Repairs						15.00		
E Lights						1.00		
E Generators						20.00		
PANELS		Service	Remote	Main			4.00	
						5.00		
						8.00		
TRANSFORMER	0-25 Kva					5.00		
	25-200 Kva					8.00		
	Over 200 Kva					10.00		
						TOTAL AMOUNT DUE		
						MINIMUM FEE/COMMERCIAL 55.00	MINIMUM FEE 45.00	

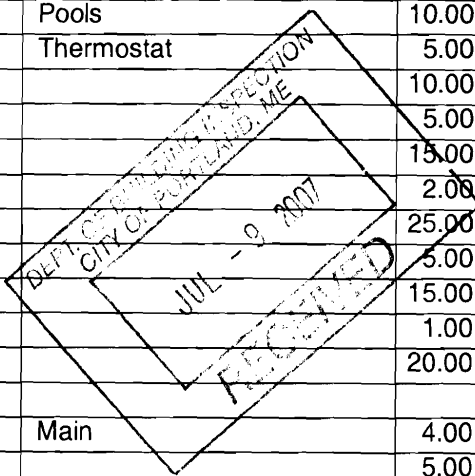

CONTRACTORS NAME Seacoast Security MASTER LIC. # _____
 ADDRESS 4 Summers + Freeport + McClellan LIMITED LIC. # _____
 TELEPHONE (207) 865-0394

SIGNATURE OF CONTRACTOR