

# EcoFoot5D™

The New High Density 5° Racking System

## Small Footprint. Big Power.

Now you can build more powerful rooftop solar systems faster and easier than ever before with the new high density EcoFoot5D™ Racking System.



Built on the Industry-Preferred EcoFoot® Platform, with More than 200MW Installed.

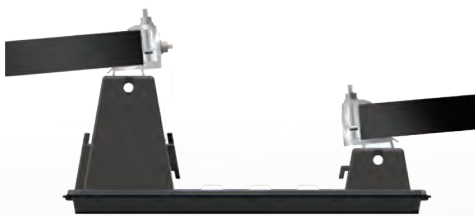

### 18.4% More Power

Small 7"x16.7" roof-friendly modular Base and dense 9.9" inter-row spacing enables a tightly packed solar array that delivers 18.4% more power than 10° systems. Whether your roof is small or large, EcoFoot5D provides more power, lowering cost-per-watt.

### Elegantly Simple Installation

EcoFoot5D delivers preassembled parts and an out-of-the-box, ready-to-go installation that is unlike any other flat-roof racking. The result is a seamless installation process from start to finish, saving on time and minimizing job-site impact.

### Cost-Saving Logistics & Support

Stackable bases enable a huge per-pallet shipping capacity. Fewer pallets are required, minimizing shipping, storage and onsite crane use. Dedicated engineering support prevents issues before they happen and provides quick solutions if obstacles arise.



Ecolibrium Solar

Contact: 740.249.1877 | sales@ecolibrumsolar.com | www.ecolibrumsolar.com

# The Simplest Way to



Built on the Industry Preferred, Innovative EcoFoot Modular Platform.

## Creating Unbeatable Solar Racking for Commercial and Residential

Since 2010, Ecolibrium Solar has revolutionized Solar Racking with the FAST & SIMPLE EcoFoot Modular Platform for flat-roof arrays and EcoX Rail-less Racking for pitched roofs. With 600MW installed on flat and pitched roofs nationwide, we bring the beauty of simplicity to solar.

## Elegant Installation, Right Out of the Box.

### Organized Work Flow and Preassembled Parts

When you're on the roof, you need ready-to-go components and a simple install. That's why installers prefer the EcoFoot Modular Platform: Bases self-align and parts are preassembled so no PV panel preparation is required, which enables non-stop installation from box to roof.

### Only with EcoFoot Modular

Now, EcoFoot5D delivers the elegant installation process only EcoFoot modular systems provide and packs the array with 18.4% more power than a 10° system.

Installer-centric design provides unsurpassed advantages:

- Simple, preassembled parts
- Self-aligning Bases fall in line as modules are placed
- Low-effort roof layout, just two chalk lines required
- No PV panel prep, non-stop install from box to roof
- Six simple installation steps
- No training required – 5-minute learning curve

## 290kW of Bases Delivered on 1 Standard Pallet.

### Efficient Logistics On and Off the Roof Increase Your Bottom Line

From shipping to deployment, the EcoFoot5D System reduces your shipping, storage and roof-loading needs significantly. The result? More profit per job.

- Stackable Bases and low part count streamline logistics
- 290kW of Bases delivered on 1 standard pallet
- Small footprint minimizes contact with roof
- Slip sheet costs are low, drainage is excellent
- Lightweight and roof-friendly
- Ideal for residential and commercial flat roofs
- Suited for mild or extreme roof undulations



Streamline logistics with up to 290kW of Bases per pallet.

# Max Out Your Roof



## 5 Simple Components. 1 Sweet System.

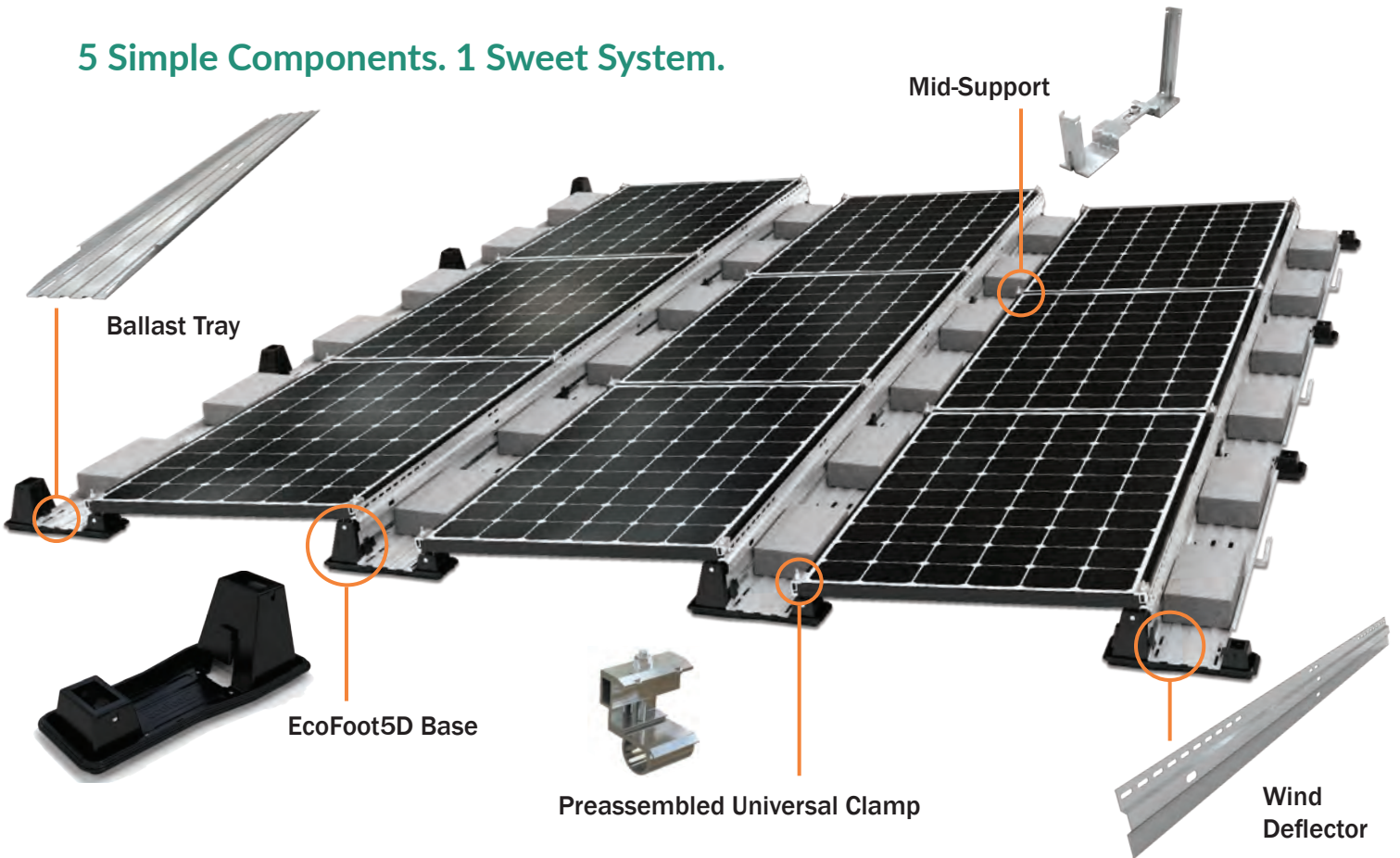

## Wire Management in a Snap.

### Accessible & Protected

Simply snap wire clips into Base to route wires between rows.

- No UV exposure: row-to-row wires covered by Ballast Tray
- Easy access to wires during install and throughout the life of the system with removable Wind Deflector and in-row ballast placement

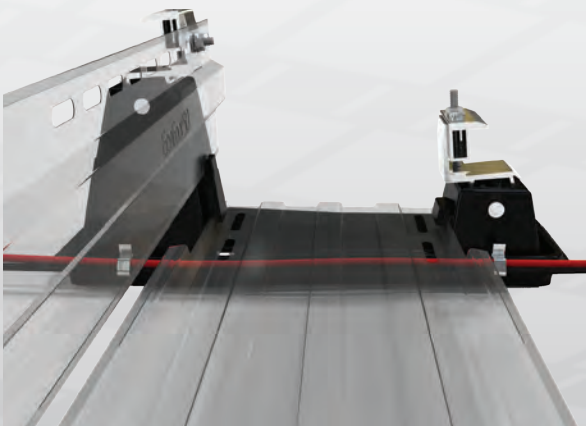

## Ballast Placement that Beats All.

### Ergonomic, Cost-Saving and Fast

Place ballasts between rows for easy reach.

- No awkward under-module access
- Rapid Ballast Tray install, sliding into Base retention clips
- Ballast Tray strong enough to walk on, even when loaded with ballast blocks
- Minimal roof contact means smaller slip sheets, lowering costs

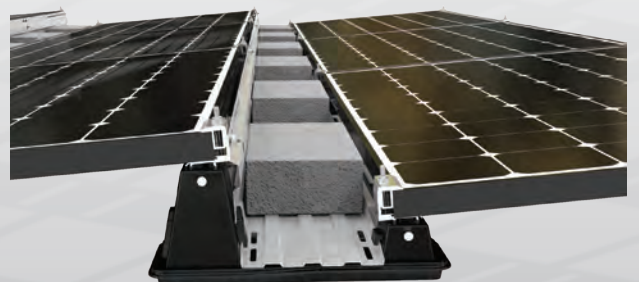

# Unbeatable EcoFoot5D

## 6 Simple Installation Steps.

### Step 1 Install Clamps in Bases – No Tools Required.



Drop preassembled Clamps into Base, push in Clevis Pins, Base is ready to install.

### Step 2 Only Two Chalk Lines Needed.



Measure & mark 2 chalk lines, Bases self-align as modules drop into place.

### Step 3 Secure PV modules onto Bases.



Space modules using alignment marks on Clamps, torque Nut provided to 14 ft-lbs.

### Step 4 Install Mid-Support.



Press the Upper and Lower Mid-Supports onto the module frame.

### Step 5 Install Ballast Tray and place ballast blocks.



Slide Tray into retention clips on Base, east/west. Place ballast blocks without reaching using sturdy, walk-on tray.

### Step 6 Install Wind Deflector.

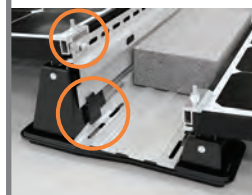

Place Wind Deflector into slot on Base, attach using Rocker Nut provided.

## Technical Specifications.

**Clamping range:** 32–50mm

**Typical system weight:** 2.4–7.7 psf

**Module orientation:** Landscape

**Tilt angle:** 5° Landscape

**Module inter-row spacing:** 9.9"

**Roof pitch:** 0° – 7°

**Ballast requirements:** 4" x 8" x 16"

**Wind tunnel tested:** 150 mph

**Warranty:** 25 years

**Slip sheets:** not required by Ecolibrium Solar. If required by roofer, use 7"x16.7" under Base; 2"x3" under Mid-Support.

## Validation Summary.

- Certified to UL2703 Fire Class A for Type I and II modules
- Certified to UL2703 Grounding and Bonding
- SEAOC seismic compliant

## Get the EcoFoot5D Advantage.

Ecolibrium Solar provides engineering support for your project from concept to completion. Contact us for a specific project bid, to schedule a product demo, or to learn more about simple, fast and cost-effective EcoFoot5D High Density 5° Racking.

Call 740.249.1877 or email [Sales@EcolibriumSolar.com](mailto:Sales@EcolibriumSolar.com)



**EcolibriumSolar**

740.249.1877 | [sales@ecolibrumsolar.com](mailto:sales@ecolibrumsolar.com) | [www.ecolibrumsolar.com](http://www.ecolibrumsolar.com) | Boulder, CO | Athens, OH

©2017 Ecolibrium Solar, Inc., EcoFoot5D is a trademark of Ecolibrium Solar, Inc. Registration pending.  
EcoFoot and Ecolibrium Solar are registered trademarks of Ecolibrium Solar, Inc.