

**City of Portland, Maine - Building or Use Permit Application**

389 Congress Street, 04101 Tel: (207) 874-8703, Fax: (207) 874-8716

Permit No: 08-0413	Issue Date:	CBL: 062 A013001
-----------------------	-------------	---------------------

Location of Construction: 33 CARROLL ST	Owner Name: MORRILL EVA	Owner Address: 33 CARROLL ST	Phone:
Business Name:	Contractor Name: Multi Spec Inc.	Contractor Address: 230 Saco Rd Hollis	Phone 2077275111
Lessee/Buyer's Name	Phone:	Permit Type: HVAC	Zone:

Past Use: single Family Home	Proposed Use: Single Family Home - New weil Mclain ASGO-7 Boiler	Permit Fee: \$140.00	Cost of Work: \$11,013.00	CEO District: 2
		FIRE DEPT: <input type="checkbox"/> Approved <input type="checkbox"/> Denied	INSPECTION: Use Group: R3 Type: ST ME Solid Fuel Burned	

Proposed Project Description: New weil Mclain ASGO-7 Boiler	Signature:	Signature: <i>Jm 4/25/08</i>
PEDESTRIAN ACTIVITIES DISTRICT (P.A.D.)		
Action: <input type="checkbox"/> Approved <input type="checkbox"/> Approved w/Conditions <input type="checkbox"/> Denied		
Signature:		Date:

Permit Taken By: Idobson	Date Applied For: 04/25/2008	<b>Zoning Approval</b>
-----------------------------	---------------------------------	------------------------

- This permit application does not preclude the Applicant(s) from meeting applicable State and Federal Rules.
- Building permits do not include plumbing, septic or electrical work.
- Building permits are void if work is not started within six (6) months of the date of issuance. False information may invalidate a building permit and stop all work..

<b>Special Zone or Reviews</b> <input type="checkbox"/> Shoreland <input type="checkbox"/> Wetland <input type="checkbox"/> Flood Zone <input type="checkbox"/> Subdivision <i>NA</i> <input type="checkbox"/> Site Plan Maj <input type="checkbox"/> Minor <input type="checkbox"/> MM <input type="checkbox"/> Date: <i>Jm 4/25/08</i>	<b>Zoning Appeal</b> <input type="checkbox"/> Variance <input type="checkbox"/> Miscellaneous <input type="checkbox"/> Conditional Use <input type="checkbox"/> Interpretation <input type="checkbox"/> Approved <input type="checkbox"/> Denied Date:	<b>Historic Preservation</b> <input type="checkbox"/> Not in District or Landmark <input checked="" type="checkbox"/> Does Not Require Review <input type="checkbox"/> Requires Review <input type="checkbox"/> Approved <input type="checkbox"/> Approved w/Conditions <input type="checkbox"/> Denied Date: <i>Jm 4/25/08</i>
---	---	--

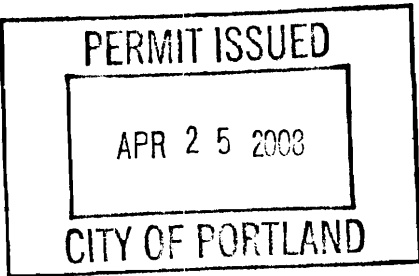

Scanned

CERTIFICATION

I hereby certify that I am the owner of record of the named property, or that the proposed work is authorized by the owner of record and that I have been authorized by the owner to make this application as his authorized agent and I agree to conform to all applicable laws of this jurisdiction. In addition, if a permit for work described in the application is issued, I certify that the code official's authorized representative shall have the authority to enter all areas covered by such permit at any reasonable hour to enforce the provision of the code(s) applicable to such permit.

SIGNATURE OF APPLICANT	ADDRESS	DATE	PHONE
RESPONSIBLE PERSON IN CHARGE OF WORK, TITLE		DATE	PHONE

05/13/09 Final duty

MTA

**City of Portland, Maine - Building or Use Permit**

389 Congress Street, 04101 Tel: (207) 874-8703, Fax: (207) 874-8716

<b>Permit No:</b> 08-0413	<b>Date Applied For:</b> 04/25/2008	<b>CBL:</b> 062 A013001
------------------------------	--	----------------------------

<b>Location of Construction:</b> 33 CARROLL ST	<b>Owner Name:</b> MORRILL EVA	<b>Owner Address:</b> 33 CARROLL ST	<b>Phone:</b>
<b>Business Name:</b>	<b>Contractor Name:</b> Multi Spec Inc.	<b>Contractor Address:</b> 230 Saco Rd Hollis	<b>Phone</b> (207) 727-5111
<b>Lessee/Buyer's Name</b>	<b>Phone:</b>	<b>Permit Type:</b> HVAC	

<b>Proposed Use:</b> Single Family Home - New weil Mclain ASGO-7 Boiler	<b>Proposed Project Description:</b> New weil Mclain ASGO-7 Boiler
--	---

**Dept:** Building      **Status:** Approved      **Reviewer:** Tom Markley      **Approval Date:** 04/25/2008**Note:**      **Ok to Issue:** 

- 1) Installation shall comply with 2003 International Mechanical Code and State of Maine Oil and Solid Fuel Board Laws and Rules
- 2) Application approval based upon information provided by applicant. Any deviation from approved plans requires separate review and approval prior to work.



FILL IN AND SIGN WITH INK

# APPLICATION FOR PERMIT HEATING OR POWER EQUIPMENT

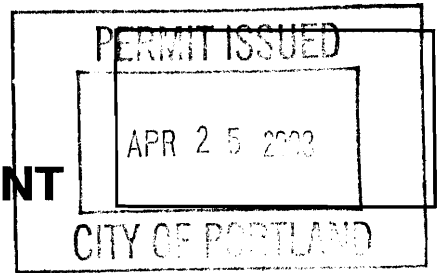

To the INSPECTOR OF BUILDINGS, PORTLAND, ME.

The undersigned hereby applies for a permit to install the following heating, cooking or power equipment in accordance with the Laws of Maine, the Building Code of the City of Portland, and the following specifications:

Location / CBL 33 Carroll St SFH Use of Building Single Family Date 4/25/08  
 Name and address of owner of appliance John and Eva Merrill  
Hollis ME  
 Installer's name and address Muit, Spoo 230 Soro Rd  
Hollis ME 04642 Telephone 727-5111

### Location of appliance:

- Basement
- Attic
- Floor
- Roof

### Type of Fuel:

- Gas
- Oil
- Solid

Appliance Name: Well Model AS60-7

U.L. Approved  Yes  No

Will appliance be installed in accordance with the manufacture's installation instructions?  Yes  No

IF NO Explain: \_\_\_\_\_

### The Type of License of Installer:

- Master Plumber # \_\_\_\_\_
- Solid Fuel # \_\_\_\_\_
- Oil # MS 30002405
- Gas # \_\_\_\_\_
- Other \_\_\_\_\_

### Type of Chimney:

- Masonry Lined  
Factory built \_\_\_\_\_
- Metal  
Factory Built U.L. Listing # \_\_\_\_\_
- Direct Vent  
Type \_\_\_\_\_ UL# \_\_\_\_\_

### Type of Fuel Tank

- Oil
- Gas

Size of Tank 275 gallon

Number of Tanks 1

Distance from Tank to Center of Flame 10 feet.

Cost of Work: \$ 11013

Permit Fee: \$ 140

### Approved

Fire: \_\_\_\_\_  
 Ele.: \_\_\_\_\_  
 Bldg.: \_\_\_\_\_

### Approved with Conditions

- See attached letter or requirement

Signature of Installer [Signature] \_\_\_\_\_

Inspector's Signature \_\_\_\_\_

Date Approved \_\_\_\_\_



# SGO RATINGS



DOE



Boiler Model Number	I-B-R Burner Capacity GPH*	DOE Heating Capacity† MBH**		Net I-B-R Ratings*			DOE Seasonal Efficiency % (AFUE)		Minimum I-B-R Chimney Size		
		Steam	Water	Steam Sq. Ft.	Steam MBH**	Water MBH**	Steam	Water	Rectangular Inches	Round Inches	Height Feet
▲-SGO-3-□	.95	114	115	356	85	100	83.5	85.0	8×8	6	15
▲-SGO-4-□	1.25	150	151	469	112	131	83.5	84.6	8×8	6	15
▲-SGO-5-□	1.50	180	182	563	135	158	83.6	84.8	8×8	7	15
▲-SGO-6-□	1.80	216	218	676	162	190	83.7	84.9	8×8	7	15
▲-SGO-7-□	2.05	246	249	770	185	217	83.7	85.1	8×8	7	15
▲-SGO-8-□	2.30	274	274	856	206	238	-	-	8×12	7	20
▲-SGO-9-□	2.55	303	303	947	227	263	-	-	8×12	8	20

▲ Substitute "P" for completely assembled package steam boiler (SGO-3 through SGO-6 only - package water boiler not available). Substitute "B" for boiler-burner unit or "A" for boiler only.

□ Add "W" for SGO boiler with water trim.

\* No. 2 fuel oil - Commercial Standard Spec. CS75-56. Heat value of oil - 140,000 BTU/Gal.

† Based on standard test procedures prescribed by the United States Department of Energy at combustion condition of 13% CO<sub>2</sub> and -0.02" W.C. draft.

\*\*MBH refers to thousands of BTU per hour.

■ I-B-R gross output.

+ Net I-B-R ratings are based on net installed radiation of sufficient quantity for the requirements of the building and nothing need be added for normal piping and pickup. Steam ratings are based on a piping and pickup allowance of 1.333; water ratings on an allowance of 1.15. An additional allowance should be made for unusual piping and pickup loads. Consult a Weil-McLain representative.

## DIMENSIONS

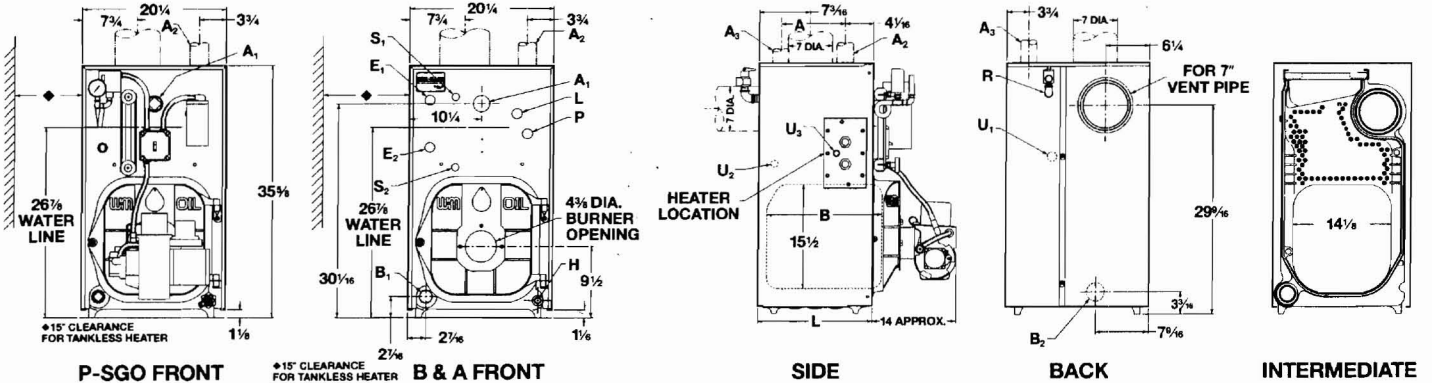

Boiler Model Number	Supply Tappings No. & Size		Return Tappings		Dimensions Inches			Approx. Shipping Wt. Lbs.*
	Steam	Water	Steam	Water	A	B	L	
SGO-3	1-2 1/2"	1-1 1/2"	2"	1 1/2"	-	13 1/2	16 1/8	600
SGO-4	1-2 1/2"	1-1 1/2"	2"	1 1/2"	-	16 1/8	20	705
SGO-5	1-2 1/2"	1-1 1/2"	2"	1 1/2"	-	19 1/8	23 3/8	820
SGO-6	2-2 1/2"	1-1 1/2"	2"	1 1/2"	19	23	26 1/4	920
SGO-7	2-2 1/2"	1-1 1/2"	2"	1 1/2"	22 1/8	26 1/8	29 3/8	990
SGO-8	2-2 1/2"	1-1 1/2"	2"	1 1/2"	25 1/4	29 1/4	32 1/2	1090
SGO-9	2-2 1/2"	1-1 1/2"	2"	1 1/2"	28 3/8	32 3/8	35 3/8	1195

CRATE MEASUREMENTS - Height: 39"; Width: 23"; Length: P-3 & 4 and B & A-3 thru 6: 37"; P-5 & 6: 43".

\*Weights based on P units (3 through 6) and B units with all components (7 through 9).

## STANDARD EQUIPMENT

- 10 Year Limited Warranty on Boiler Sections
- Factory Fire-Tested (P units only)
- Factory Water-Tested (all units)
- Factory Assembled Cast Iron Sections with the following parts installed
  - Heater Opening Cover Plate
  - Insulated Steel Jacket with Cap\*
  - Aluminized Steel Flue Collector Hood with Flue Cap on Top Outlet
  - Swing-Away Burner Mounting Door
  - Refractory Blanket and Target Wall in Combustion Area
- \*Jacket and collector hood not assembled on 7, 8 and 9 section blocks
- High Efficiency Flame Retention Oil Burner (Beckett AFG or Carlin EZ) - furnished with P and B units only
- Electrical Junction Box and Wiring Harness
- Service Switch and Junction Box Cover Plate
- Drain Valve
- Balanced Draft Damper

### SGO STEAM BOILERS

- High Limit Pressure Control
- Low Water Cutoff (Float or Probe Type) - furnished with P units only
- 15 P.S.I. ASME Safety Valve (boiler sections tested for 15 P.S.I. working pressure)
- Steam Pressure Gauge
- Siphon
- Gauge Glass, Cocks and Guards
- NOTE: On packaged steam boilers all equipment is installed and wired except safety valve and draft damper.

### SGO-W WATER BOILERS

- High Limit Control with Circulator Relay
- Combination Pressure-Temperature Gauge
- 30 P.S.I. ASME Relief Valve (boiler sections tested for 50 P.S.I. working pressure)

In the interest of continual improvement in products and performance, Weil-McLain reserves the right to change specifications without notice.



## CONTROL TAPPINGS

Location	Size Inches	Steam	Water
A <sub>1</sub>	1 1/2	Skim Tapping	Supply
A <sub>2</sub>	2 1/2	Supply	Piping to Expansion Tank or Automatic Air Vent
A <sub>3</sub>	2 1/2	Supply (SGO-6 through SGO-9)	Plugged
B <sub>1</sub>	1 1/2	Plugged	Return
B <sub>2</sub>	2	Return	Plugged
E <sub>1</sub>	1/2	Pressure Gauge & Limit Control (when probe LWCO is used)	Pressure-Temperature Gauge
E <sub>1</sub> & E <sub>2</sub>	1/2	Low Water Cutoff (Float Type)	-
H	3/4	Drain Valve	Drain Valve
L	3/4	Pressure Gauge & Limit Control (when float LWCO is used)	High Limit Control
P	3/4	Low Water Cutoff (Probe Type)	Plugged
R	3/4	Relief Valve	Relief Valve
S <sub>1</sub> & S <sub>2</sub>	1/2	Gauge Glass	Plugged
U <sub>1</sub>	1	Take off for Indirect-Fired Water Heater or Separate Zone	Plugged
U <sub>2</sub>	3/4	Tankless Heater Operating Control (SGO-6 through 9)	Plugged
U <sub>3</sub> (in heater plate)	3/4	Tankless Heater Operating Control (SGO-3 through 5)	Tankless Heater Operating Control

## ADDITIONAL EQUIPMENT

- Weil-McLain 5-Year Homeowner Protection Plan
- Weil-McLain Indirect-Fired Water Heaters
- Tankless Heaters and Controls
- Low Water Cutoffs (Float or Probe-Type)
- Two Stage Fuel Unit

Weil-McLain  
500 Blaine Street  
Michigan City, IN 46360-2388