

2 UPPER LEVEL FLOOR PLAN - SPANISH OFFICE
SCALE: 1/4" = 1'-0"

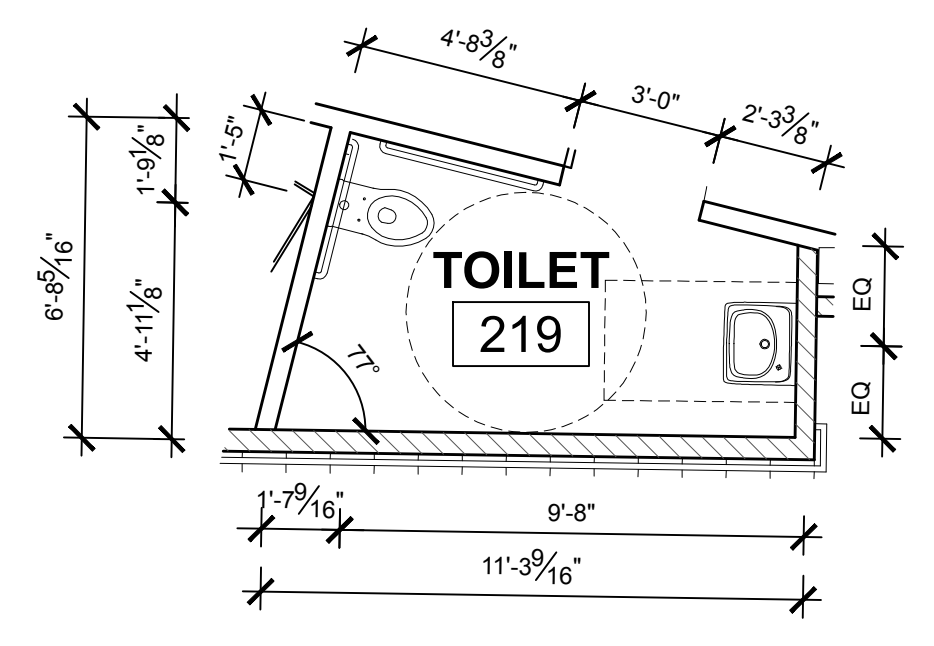

3 UPPER LEVEL FLOOR PLAN - TLT
SCALE: 1/4" = 1'-0"

1 UPPER LEVEL FLOOR PLAN
SCALE: 1/8" = 1'-0"

- GENERAL NOTES:**
1. INTERIOR WALL DIMENSIONS PROVIDED FROM CL OF WALL UNLESS OTHERWISE NOTED.
 2. DIMENSIONS FROM EXTERIOR WALLS PROVIDED FROM INSIDE FACE OF FRAMING, UNLESS OTHERWISE NOTED.
 3. ALL WINDOW DIMENSIONS DESCRIBE ROUGH OPENINGS UNLESS OTHERWISE NOTED.
 4. INTERIOR DOORS DIMENSIONED TO INSIDE FACE OF FRAME, UNLESS OTHERWISE NOTED.
 5. FLOOR DRAINS TO BE CENTERED IN ROOM UNLESS OTHERWISE NOTED.
 6. ALL CORRIDORS SERVING AS EGRESS ROUTES TO BE 6'-0" MIN CLEAR, TYP.
 7. A.S.O.G. - ABOVE SLAB ON GRADE AT EL. +128'-2"

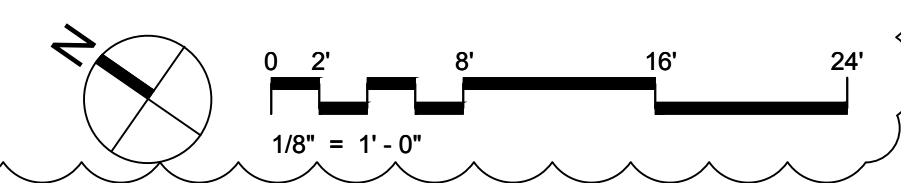

NEW SHEET

PROJECT NAME:
WAYNFLEET LOWER SCHOOL
ADDITION & RENOVATIONS

WAYNFLEET SCHOOL
360 SPRING STREET
PORTLAND, MAINE 04102

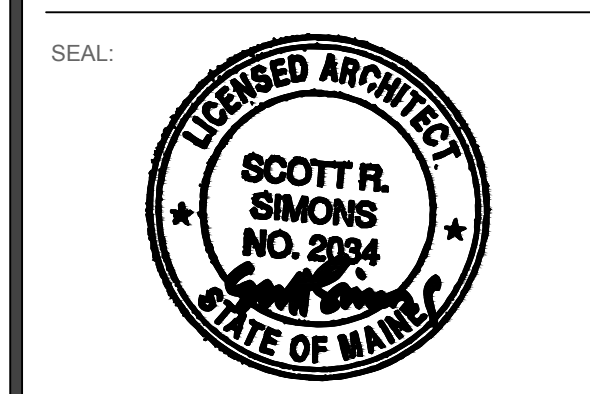

THIS DRAWING IS THE PROPERTY OF SCOTT SIMONS ARCHITECTS (SSA) AND IS NOT TO BE COPIED OR REPRODUCED IN PART OR WHOLE 2016 © SCOTT SIMONS ARCHITECTS, LLC

REVISION:

NO.	DESCRIPTION	DATE
1	ADDENDUM #1 - 30 JANUARY 2017	DATE
2	ADDENDUM #2 - 06 FEBRUARY 2017	DATE
3	ADDENDUM #3 - 15 FEBRUARY 2017	DATE
4	ADDENDUM #4 - 31 MARCH 2017 [POST BID]	DATE
5		DATE
6		DATE

DATE OF ISSUE: 12 JANUARY 2017
PROJECT NUMBER: 2013-0050
STATUS: 100% CONSTRUCTION DOCUMENTS ISSUED FOR BID

UPPER LEVEL DIMENSION PLAN

A113