



---

## **CFFWA Chilled/Hot Water Universal Mount Fan Coil**

2-Pipe Heat / Cool Fan Coil 12,000 - 60,000 BTUH

# CFFWA NOMENCLATURE BREAKDOWN

2-Pipe Heat/Cool Universal Mount Fan Coil

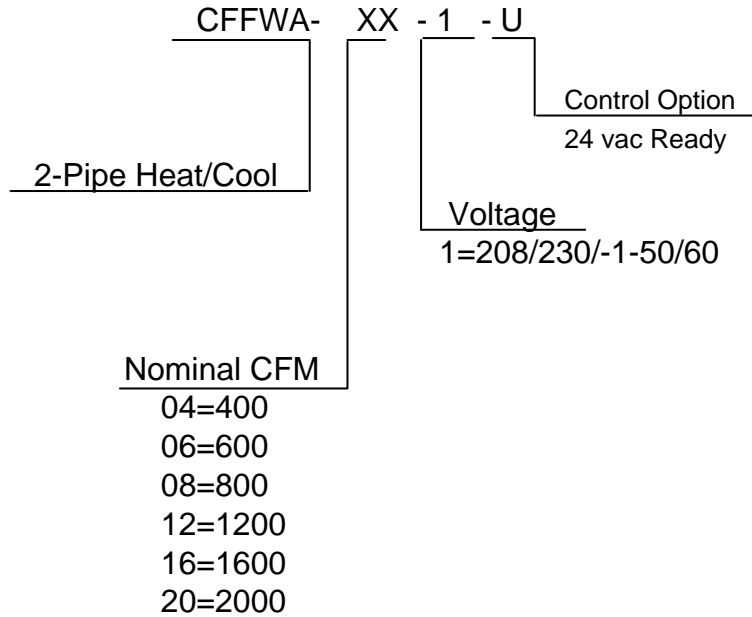

Available Model Numbers
CFFWA-04-1-U
CFFWA-06-1-U
CFFWA-08-1-U
CFFWA-12-1-U
CFFWA-16-1-U
CFFWA-20-1-U

# HVAC Guide Specifications

Chilled and Hot Water Universal Mount Fan Coil  
2-Pipe

Nominal Size:

**12,000 – 60,000 BTUH**

MultiAqua Model Number:

**CFFWA-04-1-U**  
**CFFWA-06-1-U**  
**CFFWA-08-1-U**  
**CFFWA-12-1-U**  
**CFFWA-16-1-U**  
**CFFWA-20-1-U**

## Part 1-General

### 1.01 System Description

MultiAqua Chilled Water Fan Coils are manufactured with galvanized steel and high impact molded polymers.

### 1.02 Quality Assurance

- A. Certified in accordance with U.L. Standard 95, latest version (U.S.A.)
- B. Manufactured in a facility registered to ISO 9002, Manufacturing Quality Standard.
- C. Fully load tested at the factory.
- D. Damage resistant packaging.

### 1.03 Delivery, Storage and Handling

- A. Packaged and readied for shipment from the factory.
- B. Controls shall be capable of withstanding 150°F storage temperatures in the control compartment.
- C. Stored and handled per manufacturer's recommendations.

## Part 2-Product

### 2.01 Equipment

- A. General:
  - 1. Unit shall be a factory assembled and tested chilled and hot water fan coil.
  - 2. Shall be assembled with high quality.
  - 3. Contained with the unit shall be all factory wiring, piping, associated controls and special accessories required prior to start up.
- B. Unit Cabinet:
  - 1. Composed of high impact polymers.
  - 2. Shall be internally insulated to insure quiet operation.
- C. Fan Motors:
  - 1. Shall be available in 208/230-1-50/60 vac.
  - 1. Fan motors shall be three speed, direct drive, and PSC type.
  - 2. Totally enclosed.
  - 3. Internal overload protected.
  - 4. Unit shall contain a swing motor to modulate the discharge air.
- D. Blower Wheels:
  - 1. Blower wheels are tangential and dynamically balanced.
- E. Water Coil:
  - 1. Manufactured with water coils containing 3/8" copper tubing mechanically bonded to aluminum fins.
  - 2. Coils shall be factory tested to 350 psig.
- F. Drain Pan:
  - 1. All drain pans shall be coated on both the interior and exterior with baked polyester powder to resist corrosion.
  - 2. The exterior of all drain pans shall be insulated with closed cell to prevent condensation.
  - 3. Pans shall contain a drain tubing that is accessible from the back, bottom and side of the unit.

G. Filters:

1. Unit shall contain 65% washable filters.

**Part 3-Controls and Safeties**

**3.01 Controls**

- A. Fan coils shall be completely factory wired and tested.
- B. Unit shall include a terminal block that is capable of incorporating a 24 vac thermostat.
- C. Controls shall be capable of incorporating an optional hard-wired thermostat.

**3.02 Safeties:**

- A. Fan coil shall contain a non reusable fuse on the secondary voltage side of the transformer.

**Part 4-Operating Characteristics:**

**4.01 Electrical Requirements**

- A. Electrical shall include a terminal block.
- B. Electrical power supply shall be rated to withstand 120°F operating ambient temperatures.

## CFFWA Product Specifications

<b>Physical Data</b>								
Model Number	Height (in)	Length (in)	Depth (in)	Weight (lbs)	Cooling Rows FPI	Water Inlet (in)	Water Outlet (in)	Drain (in)
CFFWA-04-1-U	25.27	40.31	9.01	79.37	2-13	1/2	1/2	1/2
CFFWA-06-1-U	25.27	40.31	9.01	83.77	3-13	1/2	1/2	1/2
CFFWA-08-1-U	25.27	40.31	9.01	88.18	4-13	1/2	1/2	1/2
CFFWA-12-1-U	25.27	52.13	9.01	116.84	3-13	3/4	3/4	1/2
CFFWA-16-1-U	25.27	75.78	9.01	158.73	3-14	3/4	3/4	1/2
CFFWA-20-1-U	25.27	75.78	9.01	163.14	4-14	1	1	1/2

<b>Electrical Data</b>						
Model Number	CFM	Volts/Phase/Hertz	Motor HP	Full Load Ampacity	Fuse or HACR Circuit Breaker Per Circuit	
					Minimum Amps	Maximum Amps
CFFWA-04-1-U	436	208/230-1-50/60	1/15	0.56	.70	2
CFFWA-06-1-U	520		1/15	0.56	.70	2
CFFWA-08-1-U	650		1/8	0.83	1.04	3
CFFWA-12-1-U	735		1/8 & 1/20	2.09	2.49	4
CFFWA-16-1-U	1360		1/8 & 1/8	3.18	3.59	5
CFFWA-20-1-U	1335		1/8 & 1/8	3.18	3.59	5

*These specifications are subject to change without notice.*

## CFFWA Chilled Water Performance Data

<b>CFFWA-04 COOLING CAPACITIES</b>					
CFM	EWT (°F)	GPM	ENTERING AIR TEMPERATURE (F)		
				80° D.B. / 67° W.B.	75° D.B. / 63° W.B.
436	42	1.5	TC	10.5	8.0
			SC	7.9	7.0
			WPD	3.6	3.6
		2.0	TC	11.8	9.0
			SC	8.4	7.4
			WPD	6.0	6.0
		2.5	TC	12.7	9.7
			SC	8.7	7.6
			WPD	9.0	9.0
		3.0	TC	13.3	10.2
			SC	9.0	7.8
			WPD	12.6	12.6

<b>CFFWA-04 COOLING CAPACITIES</b>					
CFM	EWT (°F)	GPM	ENTERING AIR TEMPERATURE (F)		
				80° D.B. / 67° W.B.	75° D.B. / 63° W.B.
436	45	1.5	TC	9.6	7.3
			SC	7.6	6.7
			WPD	3.6	3.6
		2.0	TC	10.8	8.3
			SC	8.1	7.1
			WPD	6.0	6.0
		2.5	TC	11.6	8.9
			SC	8.3	7.3
			WPD	9.0	9.0
		3.0	TC	12.2	9.3
			SC	8.6	7.5
			WPD	12.6	12.6

*These specifications are subject to change without notice.*

## CFFWA Chilled Water Performance Data

<b>CFFWA-06 COOLING CAPACITIES</b>					
CFM	EWT (°F)	GPM	ENTERING AIR TEMPERATURE (F)		
				80° D.B. / 67° W.B.	75° D.B. / 63° W.B.
520	42	3.0	TC	18.4	14.1
			SC	13.0	11.4
			WPD	14.7	14.7
		3.5	TC	19.2	14.7
			SC	13.3	11.6
			WPD	19.3	19.3
		4.0	TC	19.9	15.2
			SC	13.6	11.8
			WPD	24.3	24.3
		4.5	TC	20.3	15.5
			SC	13.7	11.9
			WPD	29.9	29.9

<b>CFFWA-06 COOLING CAPACITIES</b>					
CFM	EWT (°F)	GPM	ENTERING AIR TEMPERATURE (F)		
				80° D.B. / 67° W.B.	75° D.B. / 63° W.B.
520	45	3.0	TC	16.9	12.9
			SC	12.4	10.9
			WPD	14.7	14.7
		3.5	TC	17.6	13.5
			SC	12.7	11.1
			WPD	19.3	19.3
		4.0	TC	18.2	13.9
			SC	12.9	11.3
			WPD	24.3	24.3
		4.5	TC	18.6	14.2
			SC	13.1	11.4
			WPD	29.9	29.9

*These specifications are subject to change without notice.*

## CFFWA Chilled Water Performance Data

<b>CFFWA-08 COOLING CAPACITIES</b>					
CFM	EWT (°F)	GPM	ENTERING AIR TEMPERATURE (F)		
				80° D.B. / 67° W.B.	75° D.B. / 63° W.B.
650	42	4.0	TC	23.0	17.6
			SC	16.0	14.0
			WPD	8.3	8.3
		4.5	TC	23.8	18.2
			SC	16.3	14.2
			WPD	10.3	10.3
		5.0	TC	24.5	18.7
			SC	16.6	14.4
			WPD	12.6	12.6
		5.5	TC	25.0	19.1
			SC	16.8	14.6
			WPD	15.0	15.0

<b>CFFWA-08 COOLING CAPACITIES</b>					
CFM	EWT (°F)	GPM	ENTERING AIR TEMPERATURE (F)		
				80° D.B. / 67° W.B.	75° D.B. / 63° W.B.
650	45	4.0	TC	21.1	16.1
			SC	15.3	13.4
			WPD	8.3	8.3
		4.5	TC	21.8	16.7
			SC	15.6	13.6
			WPD	10.3	10.3
		5.0	TC	22.4	17.1
			SC	15.8	13.8
			WPD	12.6	12.6
		5.5	TC	23.0	17.5
			SC	16.0	13.9
			WPD	15.0	15.0

*These specifications are subject to change without notice.*



## CFFWA Chilled Water Performance Data

<b>CFFWA-12 COOLING CAPACITIES</b>					
CFM	EWT (°F)	GPM	ENTERING AIR TEMPERATURE (F)		
				80° D.B. / 67° W.B.	75° D.B. / 63° W.B.
735	42	6.5	TC	37.6	28.7
			SC	26.8	23.4
			WPD	12.3	12.3
		7.0	TC	38.5	29.4
			SC	27.1	23.7
			WPD	14.1	14.1
		7.5	TC	39.3	30.0
			SC	27.4	23.9
			WPD	16.1	16.1
		8.0	TC	40.0	30.5
			SC	27.7	24.1
			WPD	18.2	18.2

<b>CFFWA-12 COOLING CAPACITIES</b>					
CFM	EWT (°F)	GPM	ENTERING AIR TEMPERATURE (F)		
				80° D.B. / 67° W.B.	75° D.B. / 63° W.B.
735	45	6.5	TC	34.5	26.4
			SC	25.6	22.5
			WPD	12.3	12.3
		7.0	TC	35.3	27.0
			SC	25.9	22.7
			WPD	14.1	14.1
		7.5	TC	36.0	27.5
			SC	26.2	23.0
			WPD	16.1	16.1
		8.0	TC	36.7	28.0
			SC	26.4	23.2
			WPD	18.2	18.2

*These specifications are subject to change without notice.*

## CFFWA Chilled Water Performance Data

<b>CFFWA-16 COOLING CAPACITIES</b>					
CFM	EWT (°F)	GPM	ENTERING AIR TEMPERATURE (F)		
				80° D.B. / 67° W.B.	75° D.B. / 63° W.B.
1360	42	9.0	TC	49.8	38.0
			SC	34.8	30.4
			WPD	26.0	26.0
		9.5	TC	50.5	38.6
			SC	35.1	30.6
			WPD	28.8	28.8
		10.0	TC	51.1	39.0
			SC	35.3	30.8
			WPD	31.8	31.8
		10.5	TC	51.7	39.5
			SC	35.5	31.0
			WPD	34.9	34.9

<b>CFFWA-16 COOLING CAPACITIES</b>					
CFM	EWT (°F)	GPM	ENTERING AIR TEMPERATURE (F)		
				80° D.B. / 67° W.B.	75° D.B. / 63° W.B.
1360	45	9.0	TC	45.7	34.9
			SC	33.3	29.2
			WPD	26.0	26.0
		9.5	TC	46.3	35.4
			SC	33.5	29.4
			WPD	28.8	28.8
		10.0	TC	46.9	35.8
			SC	33.8	29.6
			WPD	31.8	31.8
		10.5	TC	47.4	36.2
			SC	33.9	29.7
			WPD	34.9	34.9

## CFFWA Chilled Water Performance Data

<b>CFFWA-20 COOLING CAPACITIES</b>					
CFM	EWT (°F)	GPM	ENTERING AIR TEMPERATURE (F)		
				80° D.B. / 67° W.B.	75° D.B. / 63° W.B.
1335	42	11.0	TC	52.2	39.8
			SC	34.6	30.1
			WPD	13.8	13.8
		11.5	TC	52.7	40.3
			SC	34.8	30.2
			WPD	15.0	15.0
		12.0	TC	53.3	40.7
			SC	35.0	30.4
			WPD	16.3	16.3
		12.5	TC	53.8	41.1
			SC	35.2	30.5
			WPD	17.6	17.6

<b>CFFWA-20 COOLING CAPACITIES</b>					
CFM	EWT (°F)	GPM	ENTERING AIR TEMPERATURE (F)		
				80° D.B. / 67° W.B.	75° D.B. / 63° W.B.
1335	45	11.0	TC	47.9	36.5
			SC	32.9	28.8
			WPD	13.8	13.8
		11.5	TC	48.4	37.0
			SC	33.1	28.9
			WPD	15.0	15.0
		12.0	TC	48.9	37.3
			SC	33.3	29.1
			WPD	16.3	16.3
		12.5	TC	49.4	37.7
			SC	33.5	29.2
			WPD	17.6	17.6

*These specifications are subject to change without notice.*

## CFFWA Hot Water Performance Data

CFFWA-04 HEATING CAPACITIES												
ENTERING AIR (°F)	CFM	GPM	WPD	ENTERING WATER TEMPERATURE (°F)								
				100°	110°	120°	130°	140°	150°	160°	170°	180°
50	436	1.5	3.6	13	15.6	18.1	20.7	23.3	25.9	28.5	31.1	33.7
		2	6	13.6	16.3	19	21.7	24.4	27.1	29.8	32.5	35.2
		2.5	9	13.9	16.7	19.5	22.3	25	27.8	30.6	33.4	36.2
		3	12.6	14.2	17	19.9	22.7	25.2	28.4	31.2	34	36.9

CFFWA-04 HEATING CAPACITIES												
ENTERING AIR (°F)	CFM	GPM	WPD	ENTERING WATER TEMPERATURE (°F)								
				100°	110°	120°	130°	140°	150°	160°	170°	180°
60	436	1.5	3.6	10.4	13	15.6	18.1	20.7	23.3	25.9	28.5	31.1
		2	6	10.8	13.6	16.3	19	21.7	24.4	27.1	29.8	32.5
		2.5	9	11.1	13.9	16.7	19.5	22.3	25	27.8	30.6	33.4
		3	12.6	11.5	14.4	17.2	20.1	23	25.9	28.7	31.6	34.5

CFFWA-04 HEATING CAPACITIES												
ENTERING AIR (°F)	CFM	GPM	WPD	ENTERING WATER TEMPERATURE (°F)								
				100°	110°	120°	130°	140°	150°	160°	170°	180°
70	436	1.5	3.6	7.8	10.4	13	15.6	18.1	20.7	23.3	25.9	28.5
		2	6	8.1	10.8	13.6	16.3	19	21.7	24.4	27.1	29.8
		2.5	9	8.3	11.1	13.9	16.7	19.5	22.3	25	27.8	30.6
		3	12.6	8.5	11.3	14.2	17	19.9	22.7	25.5	28.4	31.2

CFFWA-04 HEATING CAPACITIES												
ENTERING AIR (°F)	CFM	GPM	WPD	ENTERING WATER TEMPERATURE (°F)								
				100°	110°	120°	130°	140°	150°	160°	170°	180°
80	436	1.5	3.6	5.2	7.8	10.4	13	15.6	18.1	20.7	23.3	25.9
		2	6	5.4	8.1	10.8	13.6	16.3	19	21.7	24.4	27.1
		2.5	9	5.6	8.3	11.1	13.9	16.7	19.5	22.3	25	27.8
		3	12.6	5.7	8.5	11.3	14.2	17	19.9	22.7	25.5	28.4

*These specifications are subject to change without notice.*

## CFFWA Hot Water Performance Data

CFFWA-06 HEATING CAPACITIES												
ENTERING AIR (°F)	CFM	GPM	WPD	ENTERING WATER TEMPERATURE (°F)								
				100°	110°	120°	130°	140°	150°	160°	170°	180°
50	520	3	14.7	20.9	25	29.2	33.4	37.5	41.7	45.9	50.1	54.2
		3.5	19.3	21.2	25.5	29.7	33.9	38.2	42.4	46.7	50.9	55.2
		4	24.3	21.5	25.7	30	34.3	38.6	42.9	47.2	51.5	55.8
		4.5	29.9	21.6	25.9	30.2	34.5	38.9	43.2	47.5	51.8	56.1

CFFWA-06 HEATING CAPACITIES												
ENTERING AIR (°F)	CFM	GPM	WPD	ENTERING WATER TEMPERATURE (°F)								
				100°	110°	120°	130°	140°	150°	160°	170°	180°
60	520	3	14.7	16.7	20.9	25	29.2	33.4	37.5	41.7	45.9	50.1
		3.5	19.3	17	21.2	25.5	29.7	33.9	38.2	42.4	46.7	50.9
		4	24.3	17.2	21.5	25.7	30	34.3	38.6	42.9	47.2	51.5
		4.5	29.9	17.3	21.6	25.9	30.2	34.5	38.9	43.2	47.5	51.8

CFFWA-06 HEATING CAPACITIES												
ENTERING AIR (°F)	CFM	GPM	WPD	ENTERING WATER TEMPERATURE (°F)								
				100°	110°	120°	130°	140°	150°	160°	170°	180°
70	520	3	14.7	12.5	16.7	20.9	25	29.2	33.4	37.5	41.7	45.9
		3.5	19.3	12.7	17	21.2	25.5	29.7	33.9	38.2	42.4	46.7
		4	24.3	12.9	17.2	21.5	25.7	30	34.3	38.6	42.9	47.2
		4.5	29.9	13	17.3	21.6	25.9	30.2	34.5	38.9	43.2	47.5

CFFWA-06 HEATING CAPACITIES												
ENTERING AIR (°F)	CFM	GPM	WPD	ENTERING WATER TEMPERATURE (°F)								
				100°	110°	120°	130°	140°	150°	160°	170°	180°
80	520	3	14.7	8.3	12.5	16.7	20.9	25	29.2	33.4	37.5	41.7
		3.5	19.3	8.5	12.7	17	21.2	25.5	29.7	33.9	38.2	42.4
		4	24.3	8.6	12.9	17.2	21.5	25.7	30	34.3	38.6	42.9
		4.5	29.9	8.7	13	17.3	21.6	25.9	30.2	34.5	38.9	43.2

*These specifications are subject to change without notice.*

## CFFWA Hot Water Performance Data

CFFWA-08 HEATING CAPACITIES												
ENTERING AIR (°F)	CFM	GPM	WPD	ENTERING WATER TEMPERATURE (°F)								
				100°	110°	120°	130°	140°	150°	160°	170°	180°
50	650	4	8.3	25.2	30.3	35.3	40.4	45.4	50.4	55.5	60.5	65.6
		4.5	10.3	25.6	30.7	35.8	40.9	46	51.2	56.3	61.4	66.5
		5	12.6	25.9	31	36.2	41.4	46.6	51.7	56.9	62.1	67.3
		5.5	15	26.1	31.3	36.6	41.8	47	52.2	57.5	62.7	67.9

CFFWA-08 HEATING CAPACITIES												
ENTERING AIR (°F)	CFM	GPM	WPD	ENTERING WATER TEMPERATURE (°F)								
				100°	110°	120°	130°	140°	150°	160°	170°	180°
60	650	4	8.3	20.2	25.2	30.3	35.3	40.4	45.4	50.4	55.5	60.5
		4.5	10.3	20.5	25.6	30.7	35.8	40.9	46	51.2	56.3	61.4
		5	12.6	20.7	25.9	31	36.2	41.4	46.6	51.7	56.9	62.1
		5.5	15	20.9	26.1	31.3	36.6	41.8	47	52.2	57.5	62.7

CFFWA-08 HEATING CAPACITIES												
ENTERING AIR (°F)	CFM	GPM	WPD	ENTERING WATER TEMPERATURE (°F)								
				100°	110°	120°	130°	140°	150°	160°	170°	180°
70	650	4	8.3	15.1	20.2	25.2	30.3	35.3	40.4	45.4	50.4	55.5
		4.5	10.3	15.3	20.5	25.6	30.7	35.8	40.9	46	51.2	56.3
		5	12.6	15.5	20.7	25.9	31	36.2	41.4	46.6	51.7	56.9
		5.5	15	15.7	20.9	26.1	31.3	36.6	41.8	47	52.2	57.5

CFFWA-08 HEATING CAPACITIES												
ENTERING AIR (°F)	CFM	GPM	WPD	ENTERING WATER TEMPERATURE (°F)								
				100°	110°	120°	130°	140°	150°	160°	170°	180°
80	650	4	8.3	10.1	15.1	20.2	25.2	30.3	35.3	40.4	45.4	50.4
		4.5	10.3	10.2	15.3	20.5	25.6	30.7	35.8	40.9	46	51.2
		5	12.6	10.3	15.5	20.7	25.9	31	36.2	41.4	46.6	51.7
		5.5	15	10.4	15.7	20.9	26.1	31.3	36.6	41.8	47	52.2

*These specifications are subject to change without notice.*

## CFFWA Hot Water Performance Data

<b>CFFWA-12 HEATING CAPACITIES</b>												
ENTERING AIR (°F)	CFM	GPM	WPD	ENTERING WATER TEMPERATURE (°F)								
				100°	110°	120°	130°	140°	150°	160°	170°	180°
50	735	6.5	12.3	42.3	50.7	59.2	67.7	76.1	84.6	93	101.5	109.9
		7	14.1	42.7	51.2	59.7	68.3	76.8	85.4	93.9	102.4	111
		7.5	16.1	43	51.6	60.2	68.8	77.5	86.1	94.7	103.3	111.9
		8	18.2	43.3	52	60.7	69.4	78	86.7	95.4	104	112.7

<b>CFFWA-12 HEATING CAPACITIES</b>												
ENTERING AIR (°F)	CFM	GPM	WPD	ENTERING WATER TEMPERATURE (°F)								
				100°	110°	120°	130°	140°	150°	160°	170°	180°
60	735	6.5	12.3	33.8	42.3	50.7	59.2	67.7	76.1	84.6	93	101.5
		7	14.1	34.1	42.7	51.2	59.7	68.3	76.8	84.5	93.9	102.4
		7.5	16.1	34.4	43	51.6	60.2	68.8	77.5	86.1	94.7	103.3
		8	18.2	34.7	43.3	52	60.7	69.4	78	86.7	95.4	104

<b>CFFWA-12 HEATING CAPACITIES</b>												
ENTERING AIR (°F)	CFM	GPM	WPD	ENTERING WATER TEMPERATURE (°F)								
				100°	110°	120°	130°	140°	150°	160°	170°	180°
70	735	6.5	12.3	25.4	33.8	42.3	50.7	59.2	67.7	76.1	84.6	93
		7	14.1	25.6	34.1	42.7	51.2	59.7	68.3	76.8	85.4	93.9
		7.5	16.1	25.8	34.4	43	51.6	60.2	68.8	77.5	86.1	94.7
		8	18.2	26	34.7	43.3	52	60.7	69.4	78	86.7	95.4

<b>CFFWA-12 HEATING CAPACITIES</b>												
ENTERING AIR (°F)	CFM	GPM	WPD	ENTERING WATER TEMPERATURE (°F)								
				100°	110°	120°	130°	140°	150°	160°	170°	180°
80	735	6.5	12.3	16.9	25.4	33.8	42.3	50.7	59.2	67.7	76.1	84.6
		7	14.1	17.1	25.6	34.1	42.7	51.2	59.7	68.3	76.8	85.4
		7.5	16.1	17.2	25.8	34.4	43	51.6	60.2	68.8	77.5	86.1
		8	18.2	17.3	26	34.7	43.3	52	60.7	69.4	78	86.7

*These specifications are subject to change without notice.*

## CFFWA Hot Water Performance Data

CFFWA-16 HEATING CAPACITIES												
ENTERING AIR (°F)	CFM	GPM	WPD	ENTERING WATER TEMPERATURE (°F)								
				100°	110°	120°	130°	140°	150°	160°	170°	180°
50	1360	9	26	54.5	65.5	76.4	87.3	98.2	109.1	120	130.9	141.8
		9.5	28.8	54.9	65.8	76.8	87.8	98.8	109.7	120.7	131.7	142.6
		10	31.8	55.1	66.2	77.2	88.2	99.3	110.3	121.3	132.3	143.4
		10.5	34.9	55.4	66.5	77.5	88.6	99.7	110.8	121.8	132.9	144

CFFWA-16 HEATING CAPACITIES												
ENTERING AIR (°F)	CFM	GPM	WPD	ENTERING WATER TEMPERATURE (°F)								
				100°	110°	120°	130°	140°	150°	160°	170°	180°
60	1360	9	26	43.6	54.5	65.5	76.4	87.3	98.2	109.1	120	130.9
		9.5	28.8	43.9	54.9	65.8	76.8	87.8	98.8	109.7	120.7	131.7
		10	31.8	44.1	55.1	66.2	77.2	88.2	99.3	110.3	121.3	132.3
		10.5	34.9	44.3	55.4	66.5	77.5	88.6	99.7	110.8	121.8	132.9

CFFWA-16 HEATING CAPACITIES												
ENTERING AIR (°F)	CFM	GPM	WPD	ENTERING WATER TEMPERATURE (°F)								
				100°	110°	120°	130°	140°	150°	160°	170°	180°
70	1360	9	16	32.7	43.6	54.5	65.5	76.4	87.3	98.2	109.1	120
		9.5	28.8	32.9	43.9	54.9	65.8	76.8	87.8	98.8	109.7	120.7
		10	31.8	33.1	44.1	55.1	66.2	77.2	88.2	99.3	110.3	121.3
		10.5	34.9	33.2	44.3	55.4	66.5	77.5	88.6	99.7	110.8	121.8

CFFWA-16 HEATING CAPACITIES												
ENTERING AIR (°F)	CFM	GPM	WPD	ENTERING WATER TEMPERATURE (°F)								
				100°	110°	120°	130°	140°	150°	160°	170°	180°
80	1360	9	26	21.8	32.7	43.6	54.5	65.5	76.4	87.3	98.2	109.1
		9.5	28.8	21.9	33.9	43.9	54.9	65.8	76.8	87.8	98.8	109.7
		10	31.8	22.1	33.1	44.1	55.1	66.2	77.2	88.2	99.3	110.3
		10.5	34.9	22.2	33.2	44.3	55.4	66.5	77.5	88.6	99.7	110.8

*These specifications are subject to change without notice.*



## CFFWA Hot Water Performance Data

CFFWA-20 HEATING CAPACITIES												
ENTERING AIR (°F)	CFM	GPM	WPD	ENTERING WATER TEMPERATURE (°F)								
				100°	110°	120°	130°	140°	150°	160°	170°	180°
50	1335	11	13.8	51.9	62.3	72.7	83	93.4	103.8	114.2	124.6	134.9
		11.5	15	52.1	62.6	73	83.4	93.8	104.3	114.7	125.1	135.5
		12	16.3	52.3	62.8	73.3	83.8	94.2	104.7	115.2	125.6	136.1
		12.5	17.6	52.5	63	73.6	84.1	94.6	105.1	115.6	126.1	136.6

CFFWA-20 HEATING CAPACITIES												
ENTERING AIR (°F)	CFM	GPM	WPD	ENTERING WATER TEMPERATURE (°F)								
				100°	110°	120°	130°	140°	150°	160°	170°	180°
60	1335	11	13.8	41.5	51.9	62.3	72.7	83	93.4	103.8	114.2	124.6
		11.5	15	41.7	52.1	62.6	73	83.4	93.8	104.3	114.7	125.1
		12	16.3	41.9	52.3	62.8	73.3	83.8	94.2	104.7	115.2	125.6
		12.5	17.6	42	52.5	63	73.6	84.1	94.6	105.1	115.6	126.1

CFFWA-20 HEATING CAPACITIES												
ENTERING AIR (°F)	CFM	GPM	WPD	ENTERING WATER TEMPERATURE (°F)								
				100°	110°	120°	130°	140°	150°	160°	170°	180°
70	1335	11	13.8	31.1	41.5	51.9	62.3	72.7	83	93.4	103.8	114.2
		11.5	15	31.3	41.7	52.1	62.6	73	83.4	93.8	104.3	114.7
		12	16.3	31.4	41.9	52.3	62.8	73.3	83.8	94.2	104.2	115.2
		12.5	17.6	31.5	42	52.5	63	73.6	84.1	94.6	105.1	115.6

CFFWA-20 HEATING CAPACITIES												
ENTERING AIR (°F)	CFM	GPM	WPD	ENTERING WATER TEMPERATURE (°F)								
				100°	110°	120°	130°	140°	150°	160°	170°	180°
80	1335	11	13.8	20.8	31.1	41.5	51.9	62.3	72.7	83	93.4	103.8
		11.5	15	20.9	31.3	41.7	52.1	62.6	73	83.4	93.8	104.3
		12	16.3	20.9	31.4	41.9	52.3	62.8	73.3	83.8	94.2	104.7
		12.5	17.6	21	31.5	42	52.5	63	73.6	84.1	94.6	105.1



## CFFWA CFM and Glycol Adjustments

CAPACITY CORRECTION FACTORS												
MODEL #	CFFWA-04		CFFWA-06		CFFWA-08		CFFWA-12		CFFWA-16		CFFWA-20	
CFM	TC	SC	TC	SC	TC	SC	TC	SC	TC	SC	TC	SC
325	0.88	0.84										
350	0.90	0.86										
375	0.92	0.88										
400	0.95	0.90	0.91	0.87								
425	0.98	0.92	0.93	0.89								
450			0.95	0.91								
500			0.98	0.93	0.87	0.84						
525					0.89	0.86						
550					0.92	0.88						
575					0.94	0.90	0.88	0.82				
600					0.96	0.92	0.90	0.84				
625					0.98	0.94	0.92	0.86				
650							0.94	0.89				
675							0.96	0.91				
700							0.98	0.93				
1025												
1050											0.77	0.73
1075									0.76	0.72	0.79	0.75
1100									0.78	0.74	0.81	0.77
1125									0.80	0.76	0.83	0.79
1150									0.82	0.78	0.85	0.81
1175									0.84	0.80	0.87	0.83
1200									0.86	0.82	0.89	0.85
1225									0.88	0.84	0.91	0.87
1250									0.91	0.87	0.93	0.89
1275									0.93	0.89	0.95	0.91
1300									0.95	0.91	0.97	0.93
1325									0.97	0.93	0.99	0.95
1350									0.99	0.95	1.00	1.00

Propylene Glycol & GPM Adjustment Factors			
Ambient Temp	Propylene Glycol %	Capacity Reduction	GPM Adjustment = 100% Capacity
26° F	10%	x 0.99	x 1.01
20° F	20%	x 0.98	x 1.03
8° F	30%	x 0.98	x 1.07
-5° F	40%	x 0.97	x 1.11
-28° F	50%	x 0.96	x 1.16

Example:  
 30% Propylene Glycol Solution.  
 System capacity x 0.98  
 GPM x 1.07

*These specifications are subject to change without notice*

# INSTALLATION and OPERATION MANUAL



CFFWA





# INSTALLATION & OPERATING MANUAL

CFFWA Universal Mount Fan Coils  
12,000-60,000 BTUH

----- CAUTION -----

Care must be taken when handling sheet metal. Sheet metal parts have sharp edges and could cause injury.

## GENERAL

Read the entire contents of this manual before beginning installation. Multiaqua assumes no responsibility for equipment installed contradictory to any code requirement or installation instructions.

The components of this fan coil have been inspected at the factory and readied for shipment. Upon receiving the shipment a visual inspection of the packaging must be performed.

If any damage to the packaging is discovered, an inspection of the components must be performed and noted on the delivery documents. If component damage is found a damage claim must be filed by the receiving party against the delivery party immediately.

This product is designed and manufactured to permit installation in accordance with national codes. It is the installer's responsibility to install the product in accordance with national codes and/or prevailing local codes and regulations.

Care must be taken to ensure the structural integrity of the supporting members, clearances and provisions for servicing, power supply, coil connections and/or condensate removal. Before the installation ensure the structural strength of the supporting members is sufficient. See figure 1 for hanging weights of the fan coils.

This unit is designed to be installed in a

horizontal or vertical configuration. Fan coil can be mounted on a wall or ceiling. See figure 2 for fan coil and mounting bracket dimensions.

FAN COIL MODEL NUMBER	APPROXIMATED WEIGHTS (lbs)
CFFWA-04-1-U	79.37
CFFWA-06-1-U	83.77
CFFWA-08-1-U	88.18
CFFWA-12-1-U	116.84
CFFWA-16-1-U	158.73
CFFWA-20-1-U	163.14

Figure 1



# INSTALLATION & OPERATING MANUAL

CFFWA Universal Mount Fan Coil  
12,000-60,000 BTUH

CFFWA Mounting Bracket Dimensions (in)		
Model Number	A	B
CFFWA-04-1-U	36.49	13.00
CFFWA-06-1-U	36.49	13.00
CFFWA-08-1-U	36.49	13.00
CFFWA-12-1-U	48.30	13.00
CFFWA-16-1-U	71.97	13.00
CFFWA-20-1-U	71.97	13.00

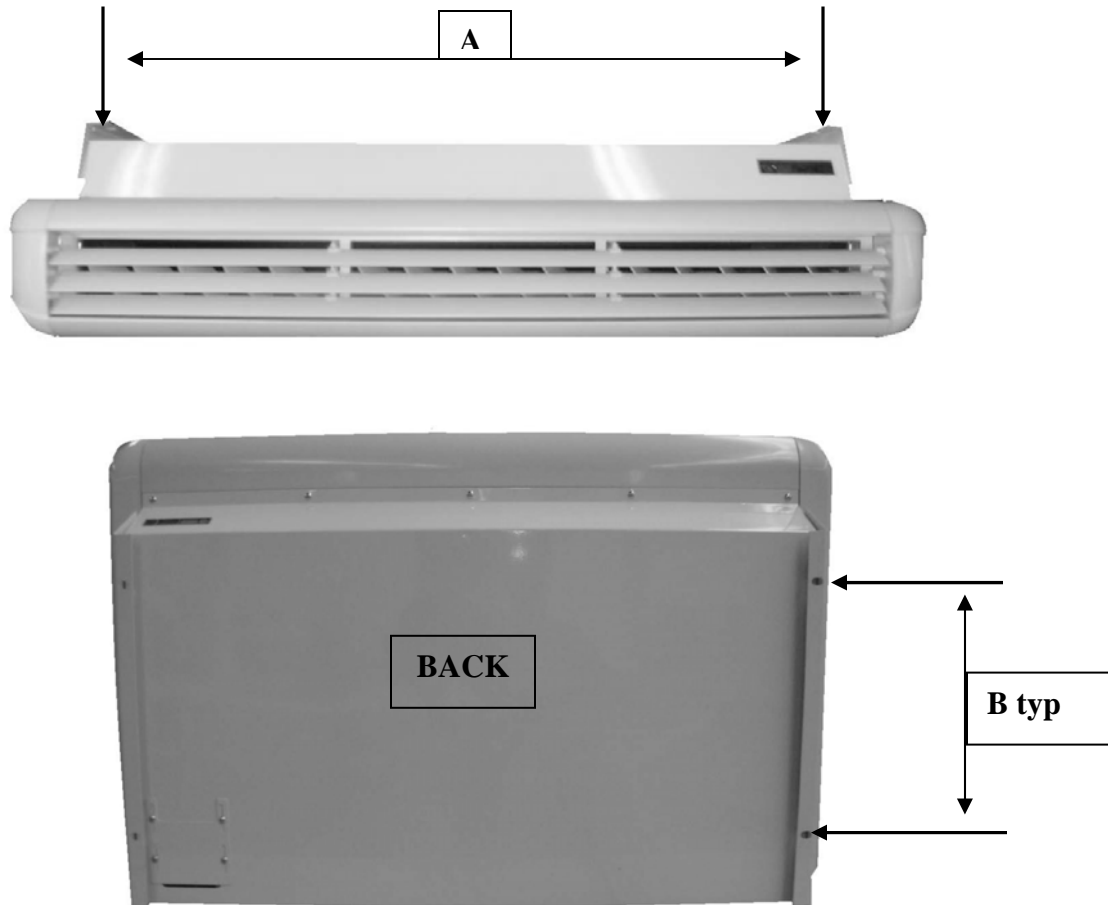

Figure 2



# INSTALLATION & OPERATING MANUAL

CFFWA Universal Mount Fan Coils  
12,000 – 60,000 BTUH

**----- CAUTION -----**

Care must be taken when handling sheet metal. Sheet metal parts have sharp edges and could cause injury.

## INSTRUCTIONS FOR INSTALLING THE MOUNTING BRACKETS AND UNIT

1. The unit should be installed for horizontal and vertical discharge applications only.
2. Select position for unit and define direction of water pipe, drain and electrical wiring. Access to the above can be obtained from the right hand side bottom, back and side. See page 229 for access dimensions.

Figure 3, 4 and 5

3. Remove mounting brackets from both sides of unit.

Figure 6

4. Prepare mounting bolts for mounting unit under ceiling or on a wall at the distance provided in figure 2.
5. Select a location that permits even air flow throughout the room.
6. Select a location that has enough service space when the unit is mounted under the ceiling or on the wall

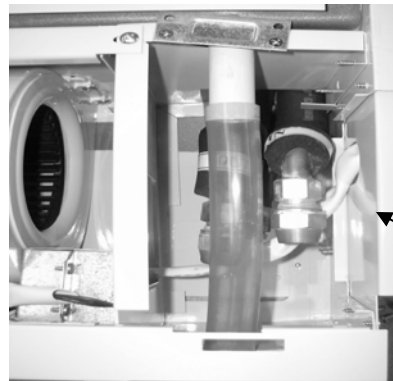

Figure 3



Figure 4



Figure 5



# INSTALLATION & OPERATING MANUAL

CFFWA Universal Mount Fan Coils  
12,000 – 60,000 BTUH

## Piping Locations

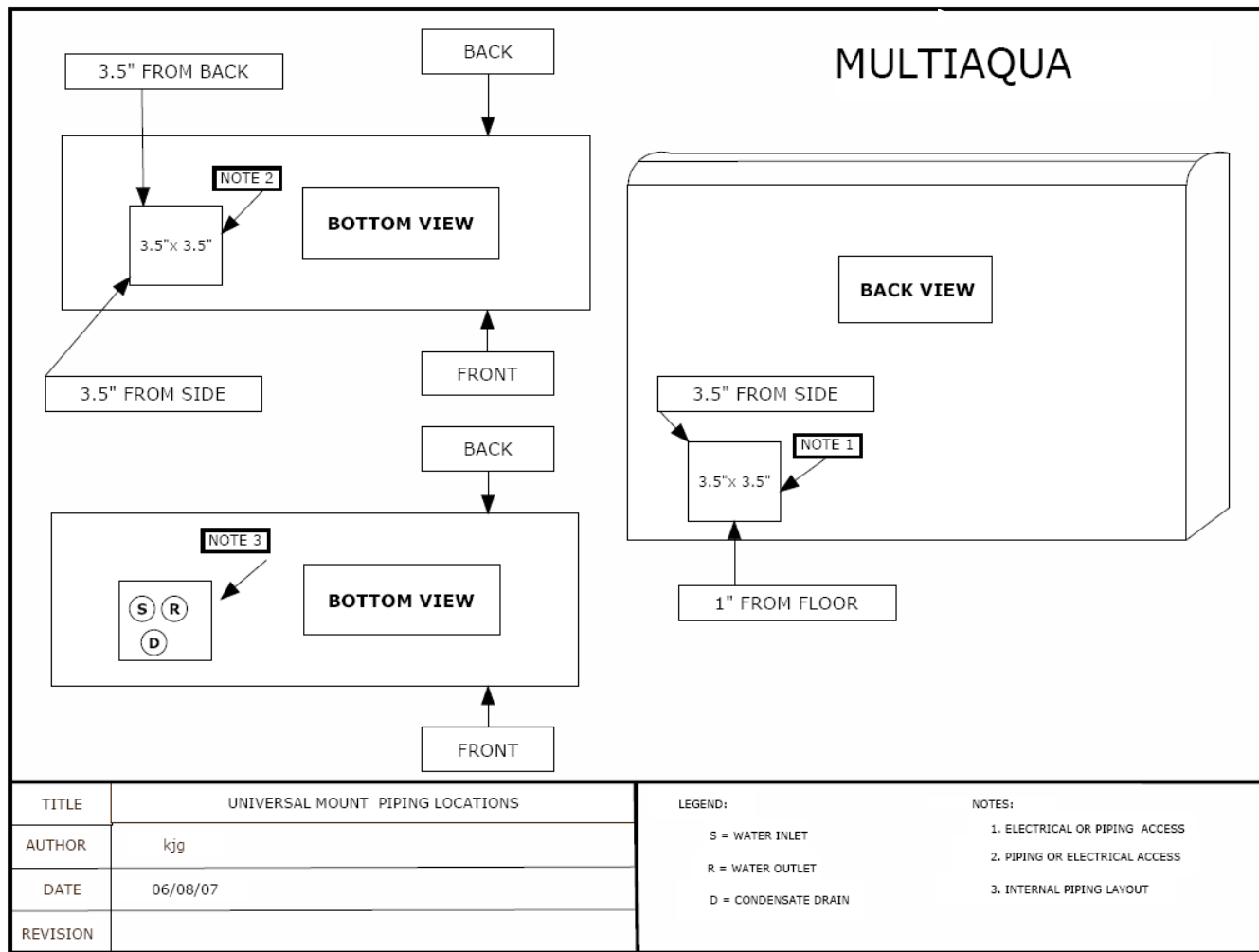





# INSTALLATION & OPERATING MANUAL

CFFWA Universal Mount Fan Coils  
12,000 – 60,000 BTUH

**----- CAUTION -----**

Care must be taken when handling sheet metal. Sheet metal parts have sharp edges and could cause injury.

## INSTRUCTIONS FOR INSTALLING THE MOUNTING BRACKETS AND UNIT

7. Carefully place fan coil into place and align mounting holes in fan coil to the holes in the mounting bracket. Typical both sides.

Figure 6

8. Connections to the indoor unit are flared connections for both the inlet and outlet to the fan coil.

Figure 7

9. Ensure tubing and fittings are in line with another before tightening nut to allow concentric seating of tube onto flare nut as to prevent leakage.

10. Insulate both the inlet and outlet liquid solution lines to prevent condensation leakage.

11. Connect the field drain line to the clear drain tubing provided on the drain pan of the fan coil. Ensure the drain line has a 1/4" of fall per foot. Insulate the condensate drain line to prevent sweating.

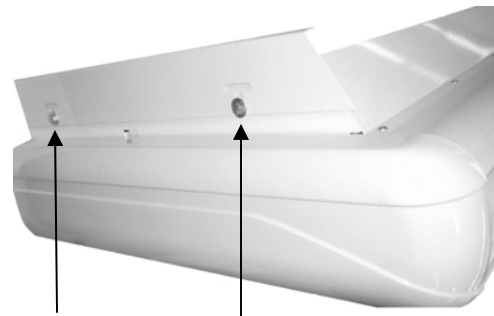

Figure 6

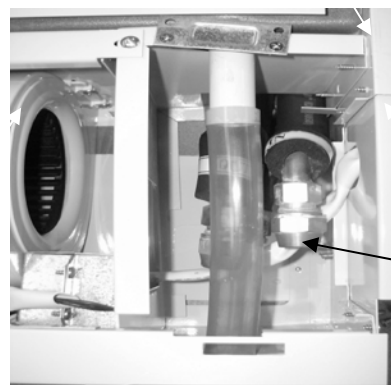

Figure 7

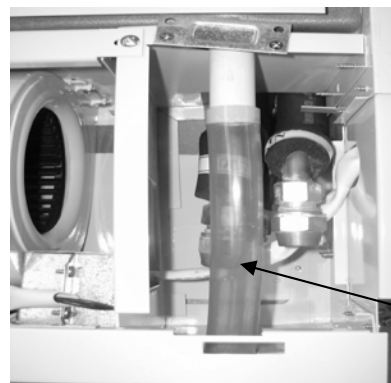
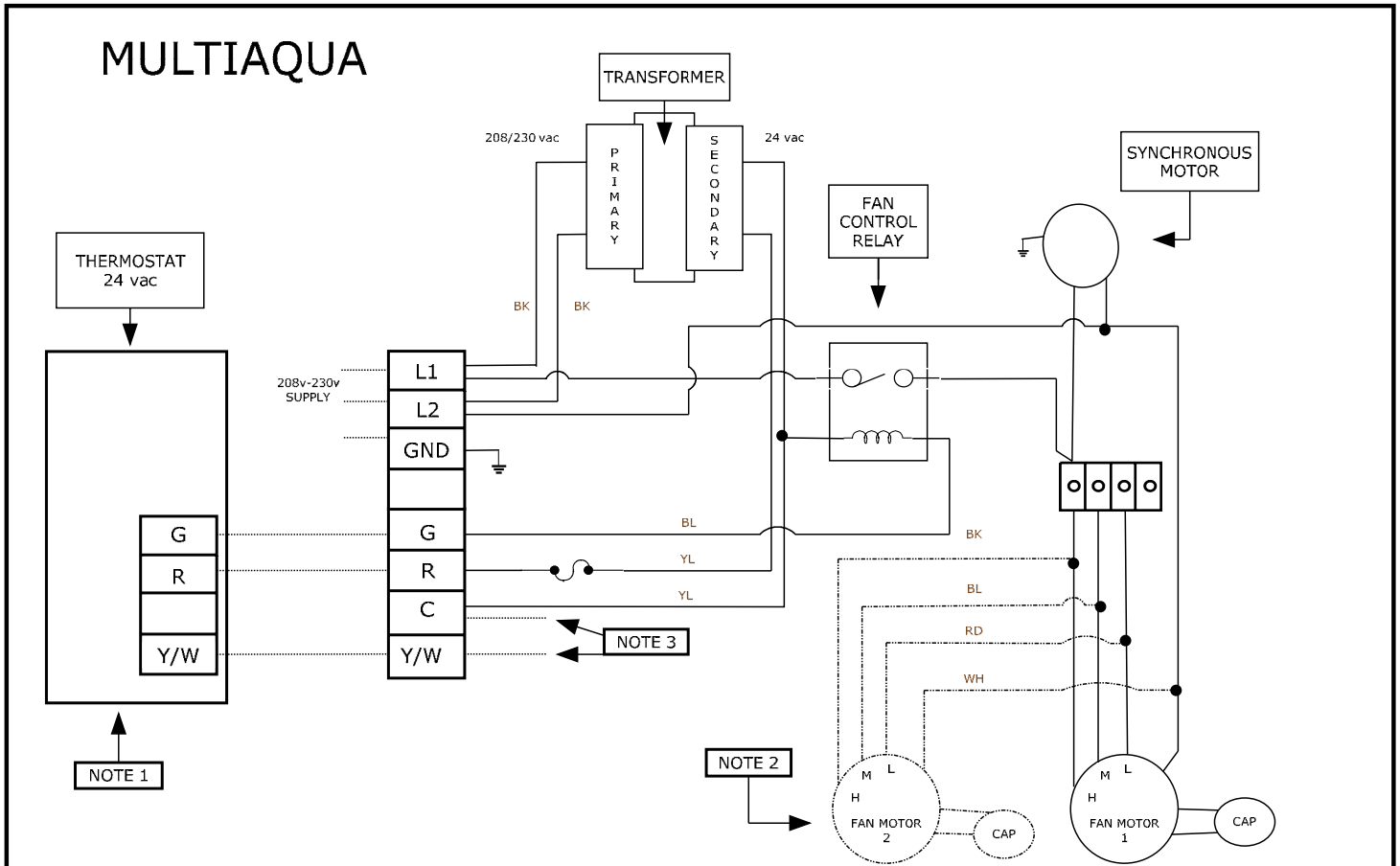

Figure 8

# CFFWA-xx-1-U Wiring Diagram

208/230/-1-50/60



TITLE	<b>CFFWA-xx-1-U WIRING DIAGRAM</b>	LEGEND:	NOTES:
AUTHOR	kjg	—	FACTORY WIRING
DATE	09/17/07	---	2 MOTOR MODEL ONLY
REVISION	0907300045	.....	FIELD WIRING
		⏏	GROUND
		⏏	FUSE
			1. Thermostat supplied by others
			2. Second motor installed on sizes 12, 16 and 20 only.
			3. Y/W and C to control valve (24vac)

# CFFWA CERTIFIED DRAWING

CFFWA Certified Drawing  
 Drawing # 0907 400073

Model CFFWA			
MODEL	A	L	
04	1024(40.32)	927(36.50)	
06	1024(40.32)	927(36.50)	
08	1024(40.32)	927(36.50)	
10	1324(52.13)	1227(48.31)	
12	1324(52.13)	1227(48.31)	
16	1925(75.79)	1828(71.97)	
20	1925(75.79)	1828(71.97)	

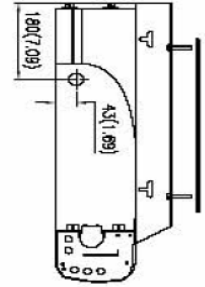

SIDE VIEW

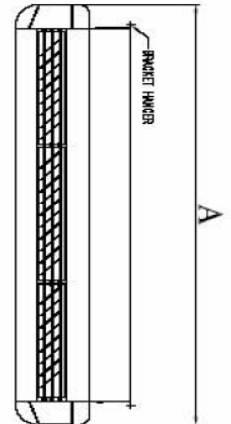

FRONT VIEW

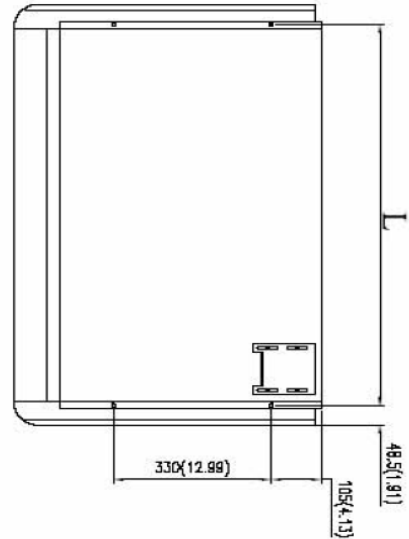

TOP VIEW

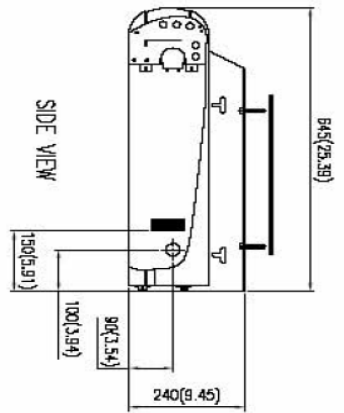

SIDE VIEW

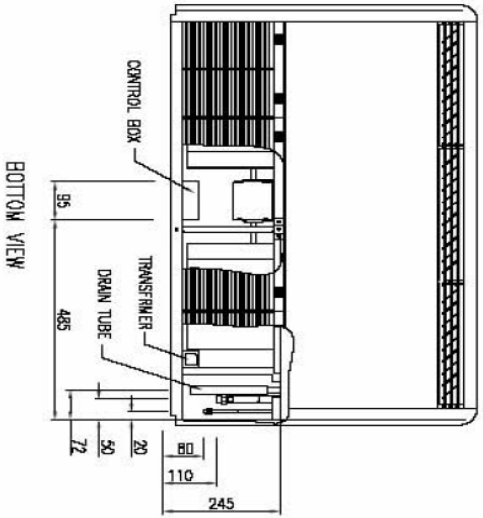

BOTTOM VIEW

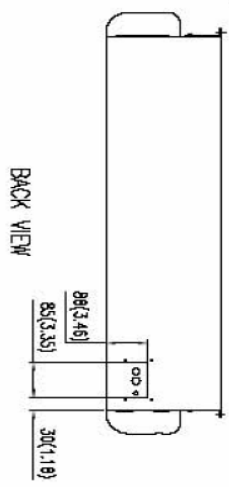

BACK VIEW

