

SLOPED ROOF: (R38) 30  
YEAR '3 TAB' ASPHALT  
ROOF SHINGLES, TYP ALL  
ROOFS U.N.O.

COPPER GUTTER  
AND DOWN SPOUT  
(AS NOTED)

1x6/1x3 FASCIA AND 1x6  
V-GROOVE SOFFIT

FULL THICKNESS SOUND  
ATTENUATION INSULATION  
(AS NOTED)

SHIPLAP SIDING W/  
SQUARE EDGE REVEAL

WALLS: DRY DENSE  
PACK CELLULOSE = R21

12  
8

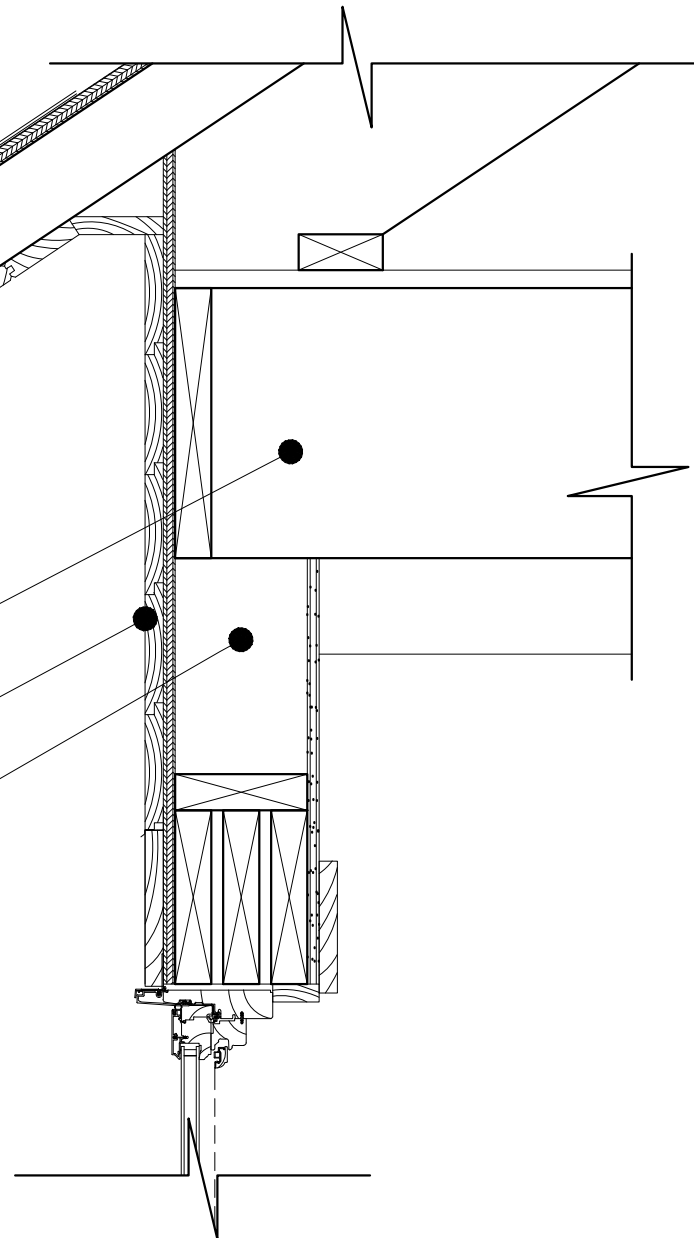

MAIN ROOF FASCIA DETAIL  
SCALE: 1 1/2"=1'-0"

SLOPED ROOF: (R38) 30  
YEAR '3 TAB' ASPHALT  
ROOF SHINGLES, TYP ALL  
ROOFS U.N.O.

COPPER DRIP EDGE  
(AS NOTED)

1x6/1x3 FASCIA AND 1x6  
V-GROOVE SOFFIT

WALLS: DRY DENSE  
PACK CELLULOSE = R21

12  
4

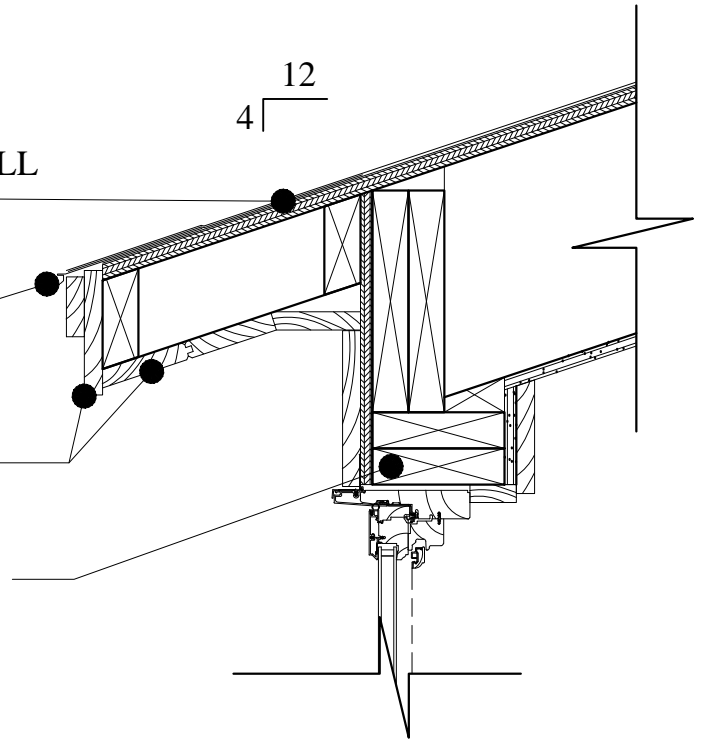

DORMER ROOF DETAIL  
SCALE: 1 1/2"=1'-0"

PROPOSED



MARK  
MUELLER  
ARCHITECTS

HP-4.0

NOVEMBER 5, 2014

HISTORIC PRESERVATION BOARD

11 ORCHARD STREET