

NEWYARD LLC
120'-0" X 160'-6"
PORTLAND, ME

Legacy Building Solutions
19500 County Rd 142
South Haven, MN 55830
p. 320-259-7126

THIS DRAWING AND THE INFORMATION CONTAINED HEREIN, REMAINS THE PROPERTY OF LEGACY BUILDING SOLUTIONS. IT IS PROVIDED TO YOU FOR YOUR INFORMATION ONLY. IT IS NOT TO BE REPRODUCED, COPIED, OR TRANSMITTED IN ANY FORM OR BY ANY MEANS, ELECTRONIC OR MECHANICAL, INCLUDING PHOTOCOPYING, RECORDING, OR BY ANY INFORMATION STORAGE AND RETRIEVAL SYSTEM, WITHOUT THE WRITTEN PERMISSION OF LEGACY BUILDING SOLUTIONS.

PATENT PENDING

DETAILS

NO.	DATE	DESCRIPTION
1		ISSUED
2		
3		
4		

Project:	120'
Site:	160'-6"
Date:	11/13/15
Drawn By:	DAVID WOODRUFF

Sheet Number:

S5.0

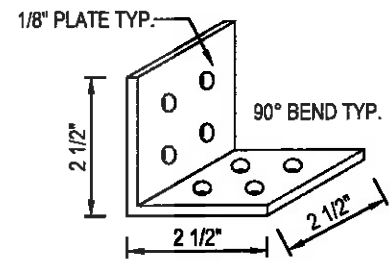

CLIP: b1

5/16" Ø HOLES TYP.

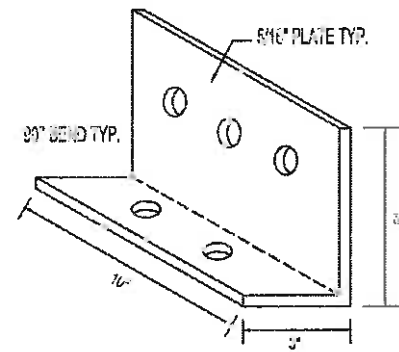

CLIP: b2

13/16" Ø HOLES TYP.

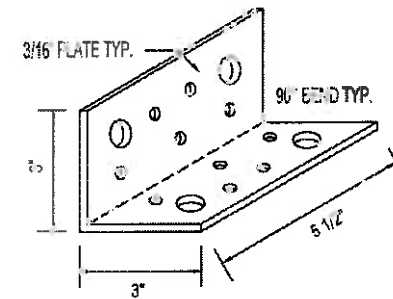

CLIP: b4

3/16" AND 13/16" Ø HOLES

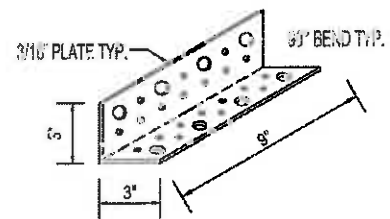

CLIP: b5

3/16" AND 13/16" HOLES

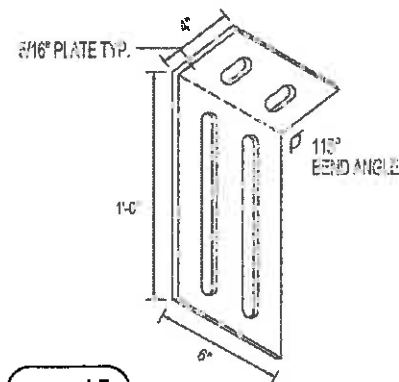

CLIP: b7

13/16" SLOTS

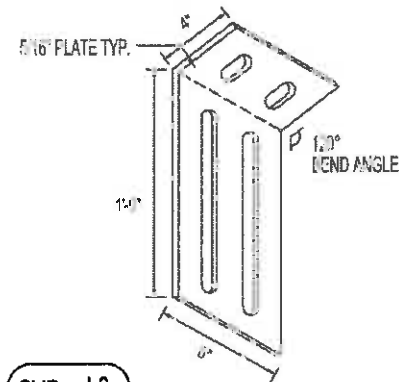

CLIP: b8

13/16" SLOTS

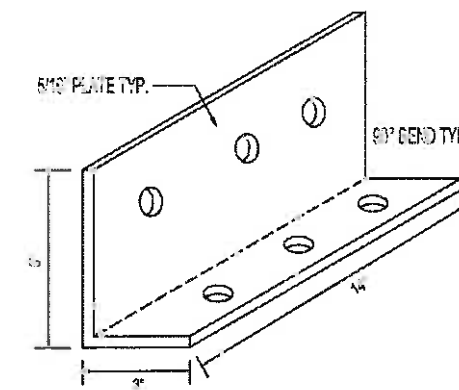

CLIP: b10

5/16" HOLES TYP.

