

**1** SIDEWALL DOOR FRAME DETAIL  
SCALE: 3/4" = 1'-0"

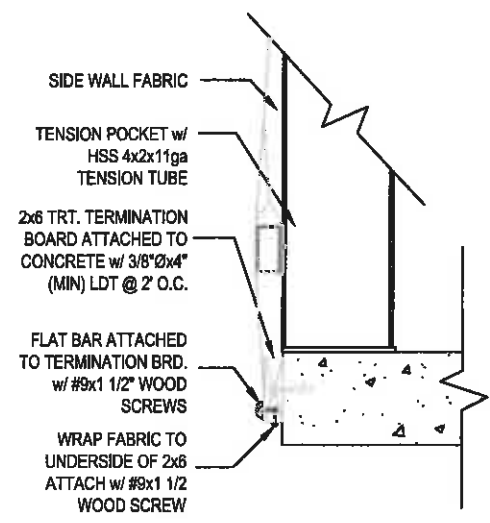

**2** SIDE WALL TERMINATION  
SCALE: 3/4" = 1'-0"

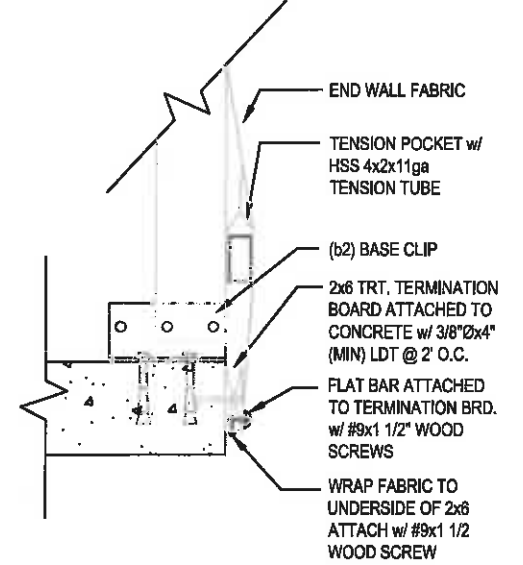

**3** END WALL TERMINATION  
SCALE: 3/4" = 1'-0"

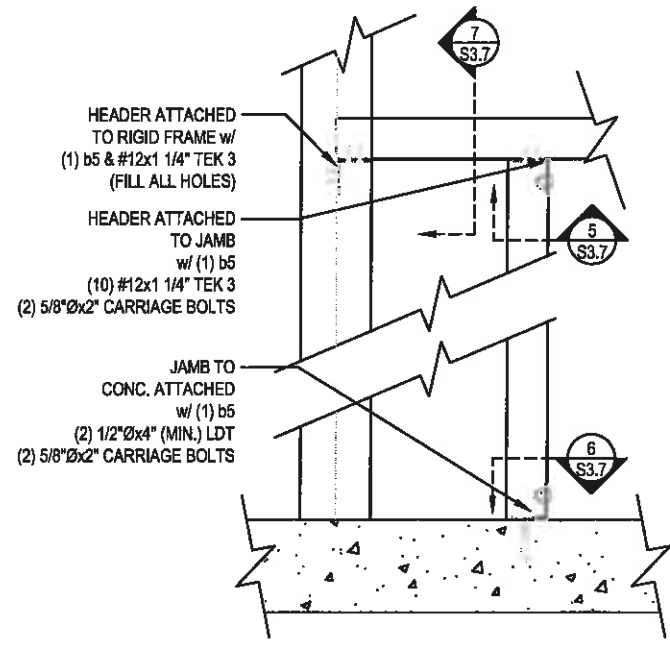

**4** 12C12 DOOR FRAME DETAIL  
SCALE: 3/4" = 1'-0"

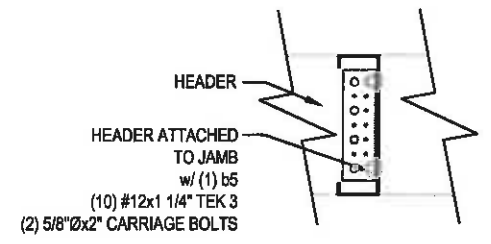

**5** 12C12 HEADER TO JAMB  
SCALE: 3/4" = 1'-0"

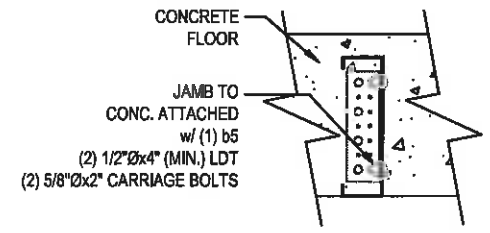

**6** 12C12 JAMB TO CONCRETE  
SCALE: 3/4" = 1'-0"

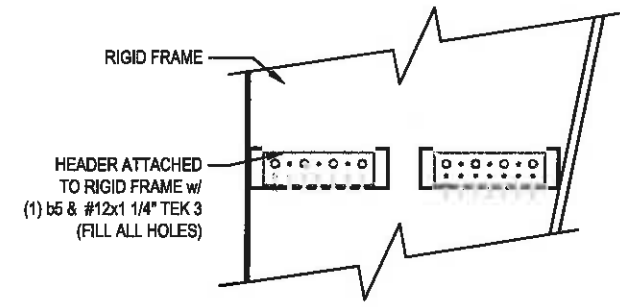

**7** 12C12 TO RIGID FRAME  
SCALE: 3/4" = 1'-0"

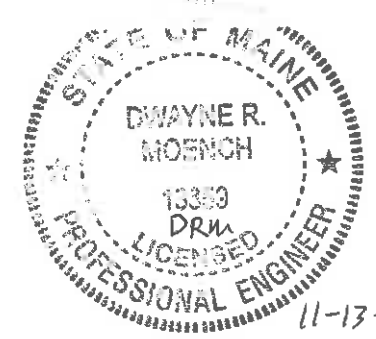

11-13-13



**NEW YARD LLC**  
120'-0" X 160'-8"  
PORTLAND, ME

Legacy Building Solutions  
19500 County Rd 142  
South Haven, MN 55830  
p. 320-259-7126

THIS DOCUMENT IS THE PROPERTY OF LEGACY BUILDING SOLUTIONS. IT IS TO BE USED ONLY FOR THE PROJECT AND SITE SPECIFICALLY IDENTIFIED HEREIN. IT IS NOT TO BE REPRODUCED, COPIED, OR TRANSMITTED IN ANY FORM OR BY ANY MEANS, ELECTRONIC OR MECHANICAL, INCLUDING PHOTOCOPYING, RECORDING, OR BY ANY INFORMATION STORAGE AND RETRIEVAL SYSTEM, WITHOUT THE WRITTEN PERMISSION OF LEGACY BUILDING SOLUTIONS.

PATENT PENDING

SIDE WALL FRAMING DETAILS

NO.	DESCRIPTION	DATE
1	ISSUED FOR PERMIT	11-13-13
2		
3		
4		

DATE:	11-13-13
BY:	D.M.
CHKD:	D.M.
APP'D:	D.M.

Sheet Number:

S3.7