

15RLS2 Submittal

AOU15RLS2, ASU15RLS2

Inverter Driven Heat Pump

Job Name: Bob Fiske / Leslie Pohl

Location: 263 York Street, Portland

Engineer: n/a

Submitted to: City of Portland

Submitted by: Goggin Energy

Reference: n/a

Approval: _____

Date: _____

Construction: _____

Unit #: _____

Drawing #: _____

Outdoor Unit Power 208-230VAC-1Ph-60Hz
 Available Voltage Range 187-253VAC
 Fuse Size, Max. 20A
 MCA 13.5A

Compressor Inverter Driven Variable Speed DC Rotary
 No. used 1
 Output 1000W
 Lubricant Oil POE (RB68)

Fan type Propeller
 Motor Output 115W
 Airflow Rate Cooling/Heating (High) 1206 / 1082CFM

Refrigerant R410A
 Outdoor Unit 2lbs 12.0oz
 Control Electronic Expansion Valve
 O.D. Discharge (in) 1/4" (Flare)
 O.D. Suction (in) 1/2" (Flare)

Dimensions H x W x D
 Uncrated (in) 24-1/2 x 31-3/32 x 11-11/32
 (mm) (620 x 790 x 290)
 Crated (in) 28-1/16 x 37-7/32 x 15-9/16
 (mm) (713 x 945 x 395)

Weight Outdoor
 Net 86lbs (39kg)
 Gross Shipping 95lbs (43kg)

Cooling
 Rated Capacity 14,500BTU/h
 Min-Max Capacity 3,100~18,400BTU/h
 Rated Power Input 4.25kw
 Max. Power Input 5.40kw
 SEER 21.5
 Outdoor Sound Rating 51dB

Heating
 Rated Capacity 18,000BTU/h
 Min-Max Capacity 3,100~23,900BTU/h
 Rated Power Input 5.28kw
 Max. Power Input 7.00kw
 HSPF 12
 Outdoor Sound Rating 51dB

Piping Lengths
 Max. Piping Length (Total) 66ft
 Max. Pipe Height Difference 49ft
 Connection method (Flared)

Operating Range
 Cooling 14°F~115°F DB
 Heating -5°F~75°F DB

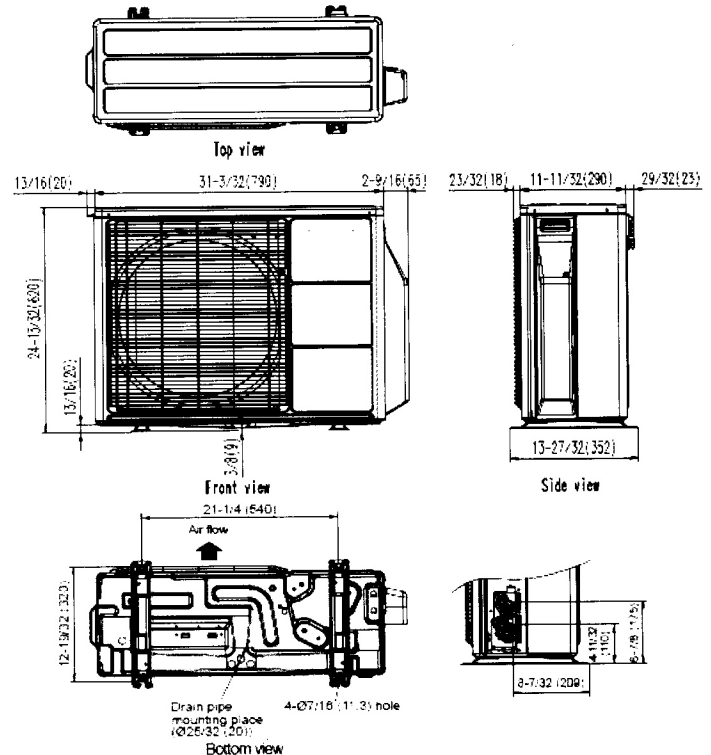
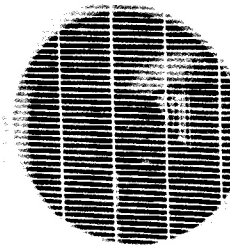

Fujitsu General America, Inc.
 Fairfield, NJ 07004
 Toll Free: 1-888-888-3424
 Fax: (973) 836-0447
 www.fujitsugeneral.com

Fujitsu products are subject to continuous improvements. Fujitsu reserves the right to modify product design, specifications and information in this data sheet without notice and without incurring any obligations.

Note: Specifications are based on the following conditions.

Power source of specifications : 230V

Cooling: Indoor temperature of 80°F(26.67°C)DB / 67°F(19.44°C)WB, and outdoor temperature of 95°F(35°C)DB/75°F(23.89°C)WB.

Heating: Indoor temperature of 70°F(21.11°C)DB / 60°F(15.56°C)WB, and outdoor temperature of 47°F(8.33°C)DB/43°F(6.11°C)WB.

Pipe length : 24ft. 7in.(7.5m), Height difference : 0 ft.(0m) [Outdoor unit - Indoor unit]



FUJITSU

Ir door Unit Power	208-230/VAC-1Ph-60Hz	
Available Voltage Range	187-253VAC	
Fan type	Cross flow	
Motor Output	29W	
NCA	0.4A	
Sound Pressure Level		
Cooling	Lo-Hi	25-45dB
Heating	Lo-Hi	25-45dB
Airflow rate		
Cooling	Lo-Hi	229-529dB
Heating	Lo-Hi	253-559dB
Dimensions	H x W x D	
Uncrated	(in)	11-3/32 x 34-1/4 x 7-9/32
	(mm)	(282 x 870 x 185)
Crated	(in)	9-23/32 x 36-7/32 x 14-11/16
	(mm)	(247 x 920 x 373)
Weight	Indoor	
Net	21lbs (9.5kg)	
Gross Shipping	27lbs (12kg)	

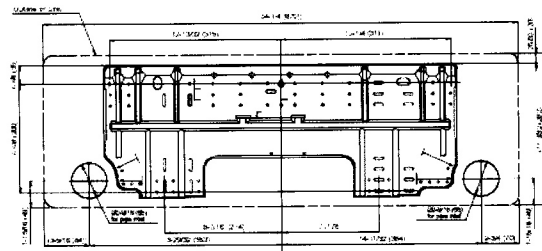
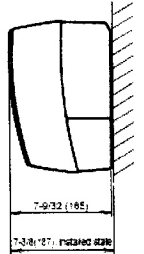
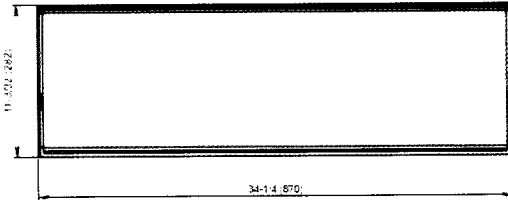

Fujitsu General America, Inc.
 Fairfield, NJ 07004
 Toll Free: 1-888-888-3424
 Fax: (973) 836-0447
 www.fujitsugeneral.com

Fujitsu products are subject to continuous improvements. Fujitsu reserves the right to modify product design, specifications and information in this data sheet without notice and without incurring any obligations.

