

1 TYPICAL DETAIL @ GARAGE
A3 1 1/2"=1'-0"

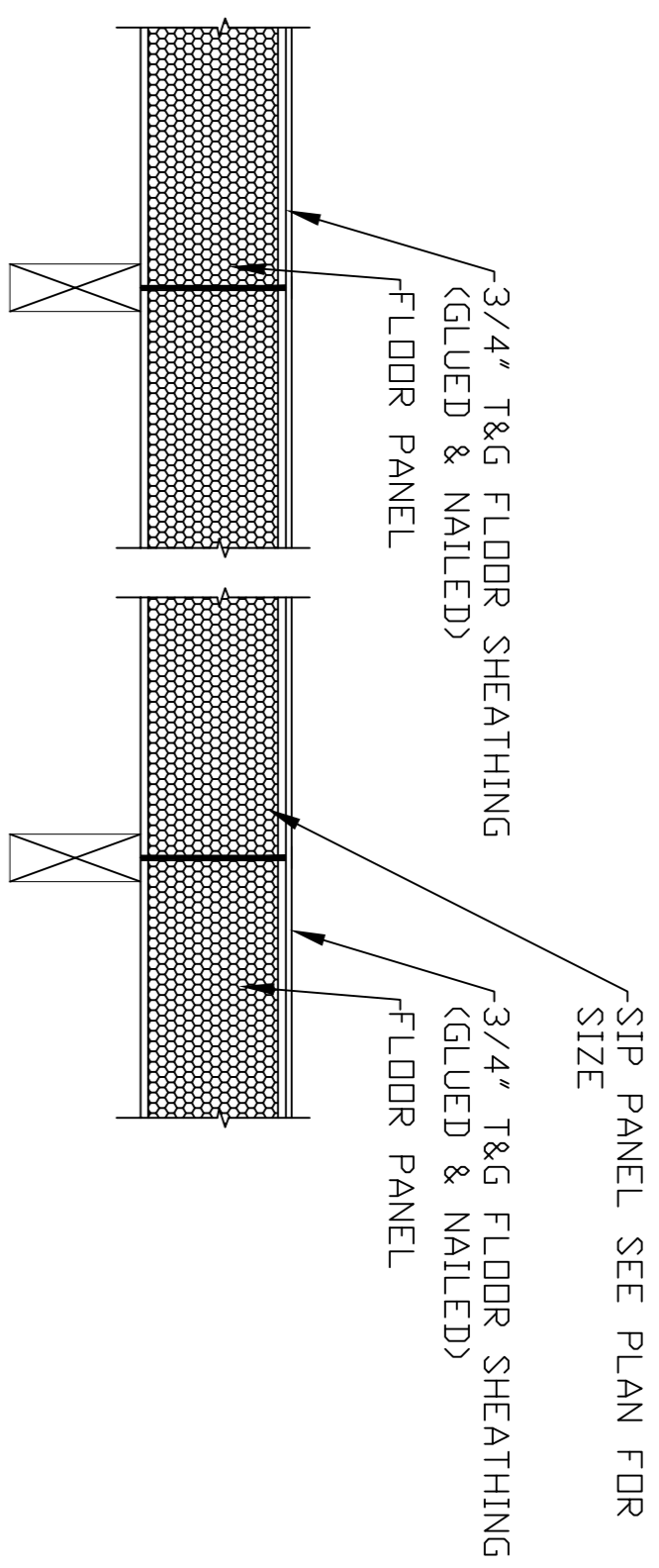

2 TYPICAL DETAIL
A4 3/4"=1'-0"

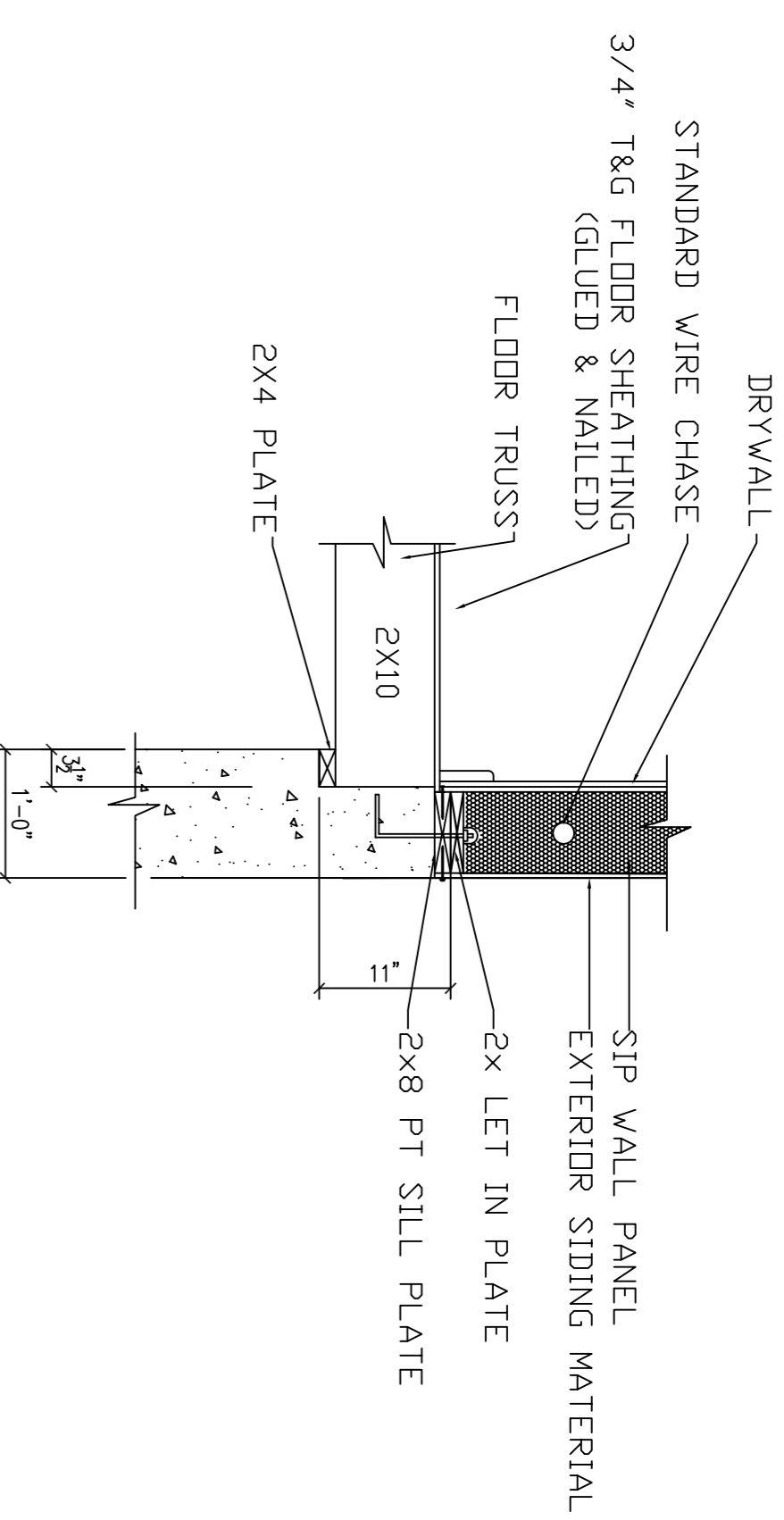

3 TYPICAL DETAIL
A4 3/4"=1'-0"

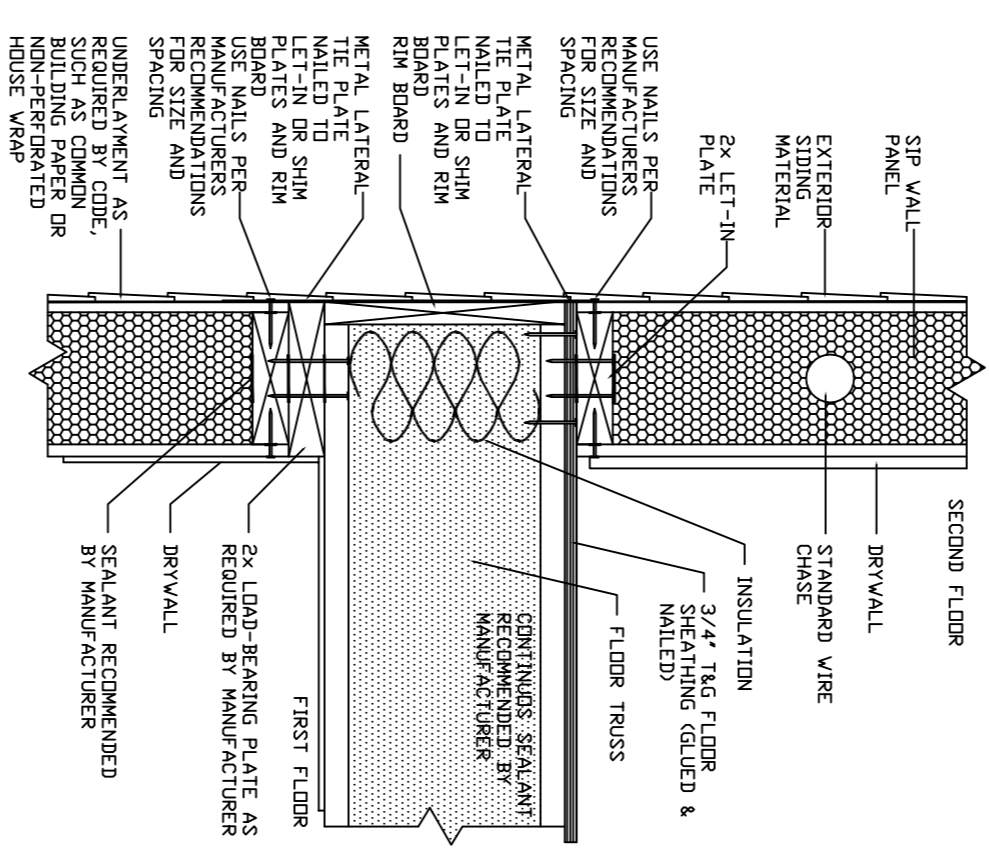

7 TYPICAL DETAIL
A3 1 1/2"=1'-0"

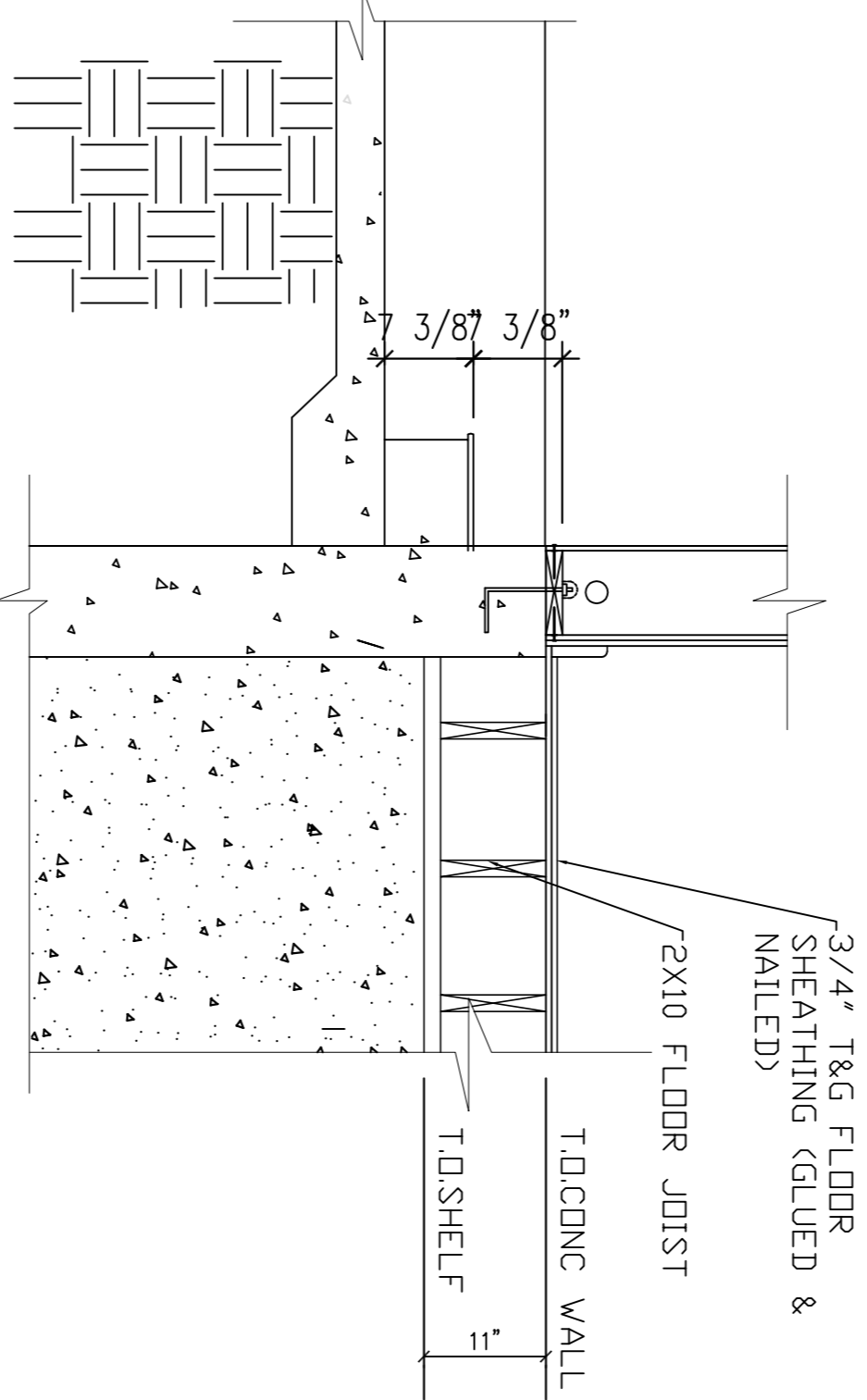

6 TYPICAL DETAIL
A3 3/4"=1'-0"

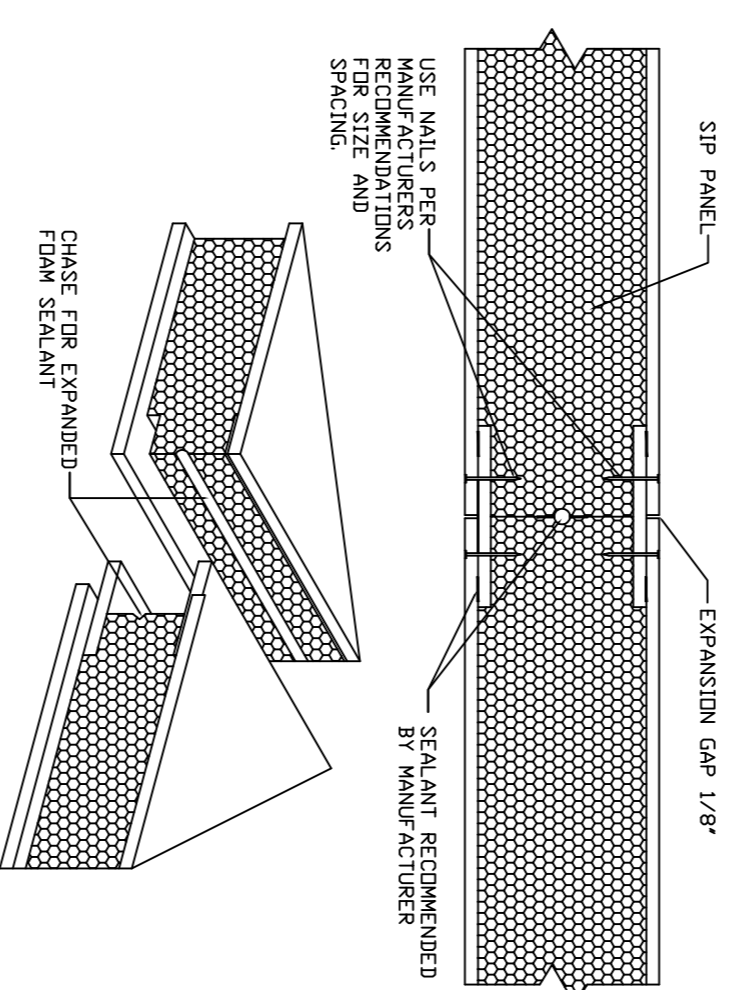

TYPICAL DETAIL
N.T.S.

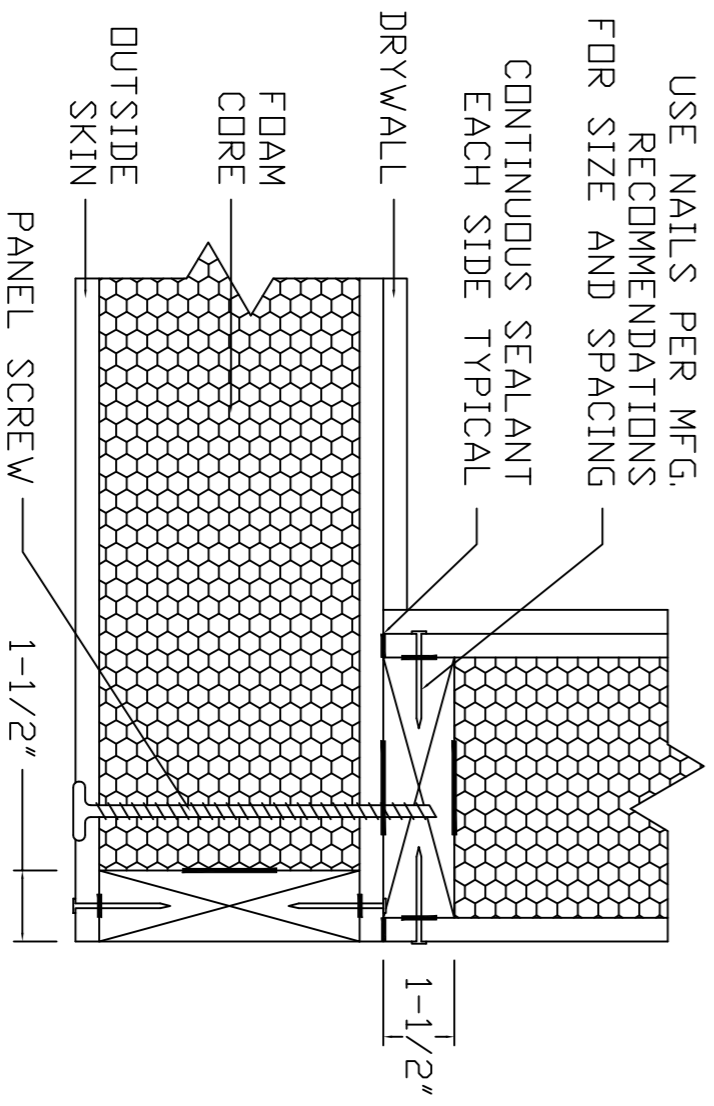

TYPICAL CORNER ATTACHMENT DETAIL
N.T.S.

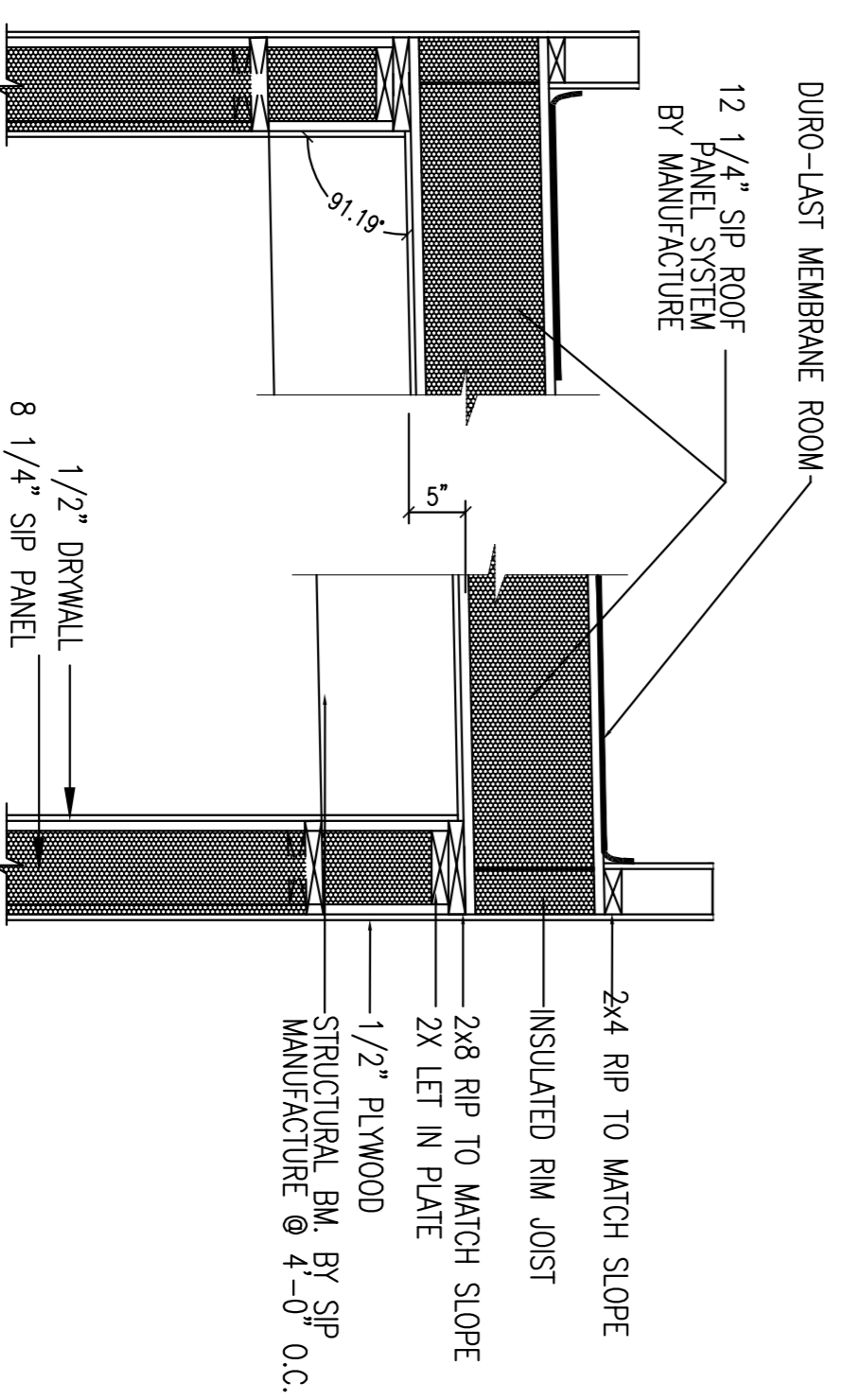

7 TYPICAL ROOF DETAIL
A4 3/4"=1'-0"

NOTE:
THIS DRAWING IS PROVIDED FOR INFORMATIONAL PURPOSES ONLY. IF USED FOR CONSTRUCTION, THE CONTRACTOR ASSUMES ALL RESPONSIBILITY FOR LOCAL CODE COMPLIANCE. ALL DIMENSIONS AND MATERIALS ARE BASED ON INFORMATION PROVIDED BY THE CLIENT AND LOCAL CODES. NONE OF THE DIMENSIONS OR MATERIALS OR SERVICES ARE REGISTERED ARCHITECTS, ENGINEERS OR LAND SURVEYORS. THE CONTRACTOR SHALL VERIFY ALL DIMENSIONS AND MATERIALS BEFORE ACTUAL CONSTRUCTION. BEING AN ARCHITECT, I AM NOT A REGISTERED ARCHITECT, ENGINEER OR LAND SURVEYOR. BEING AN ARCHITECT, I AM NOT A REGISTERED ARCHITECT, ENGINEER OR LAND SURVEYOR. BEING AN ARCHITECT, I AM NOT A REGISTERED ARCHITECT, ENGINEER OR LAND SURVEYOR.

NOTE:
G.C. TO MATCH SIP MANUFACTURE SPECIFICATION DURING INSTALLATION

McCain Residence
45 Summer St.
Portland, Maine 04102

PROPERTY OF
ACADWORX
ARCHITECTURAL DRAFTING SERVICES
844 ROOSEVELT TRAIL, WINDHAM, MAINE 04092
P. 207-678-8511 C. 207-415-5065

FILE:	SHEET:
	A-6
TITLE:	TYPICAL DETAIL
DRAWN:	SSA
DESIGNED:	SSA
SCALE:	AS NOTED
DATE:	04-10-13
TOWN:	Portland
CODE:	
REVS:	1.
2.	