

2 BUILDING SECTION
1/4" = 1'-0"

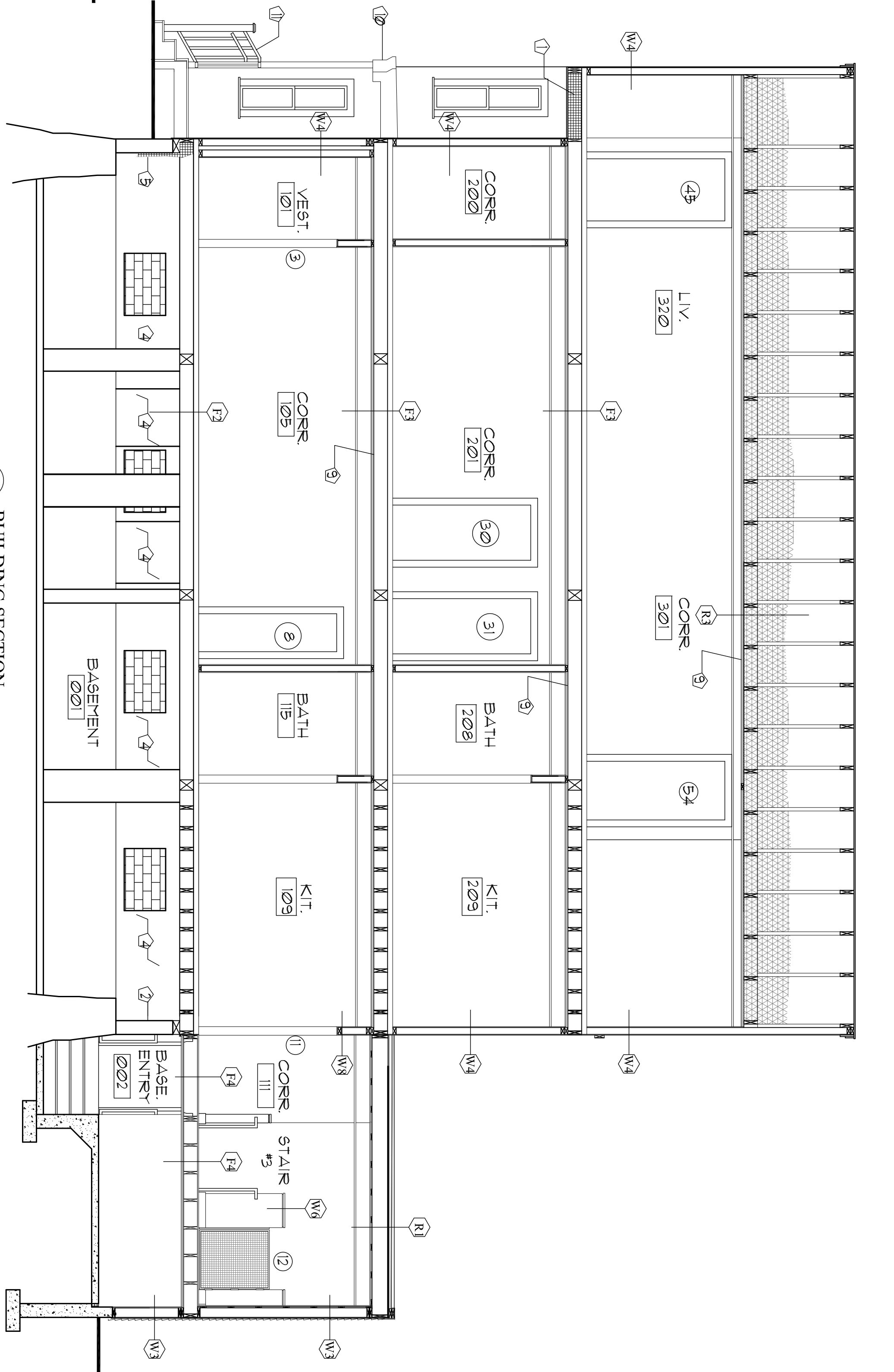

1 BUILDING SECTION
1/4" = 1'-0"

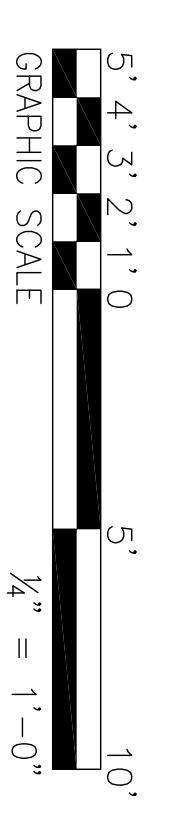

- KEYED NOTES - DETAIL A
- 1 VINYL COVERED METAL HANDRAIL, TOP OF HANDRAIL, AT 2'-10"
 - 2 VINYL COVERED METAL GUARD RAIL SYSTEM, TOP OF GUARDRAIL AT 3'-6"
 - 3 VINYL COVERED METAL POST
 - 4 EXISTING PORCH ROOF STEPS, DECKING STRUCTURE

A PORCH RAILINGS
3/4" = 1'-0"

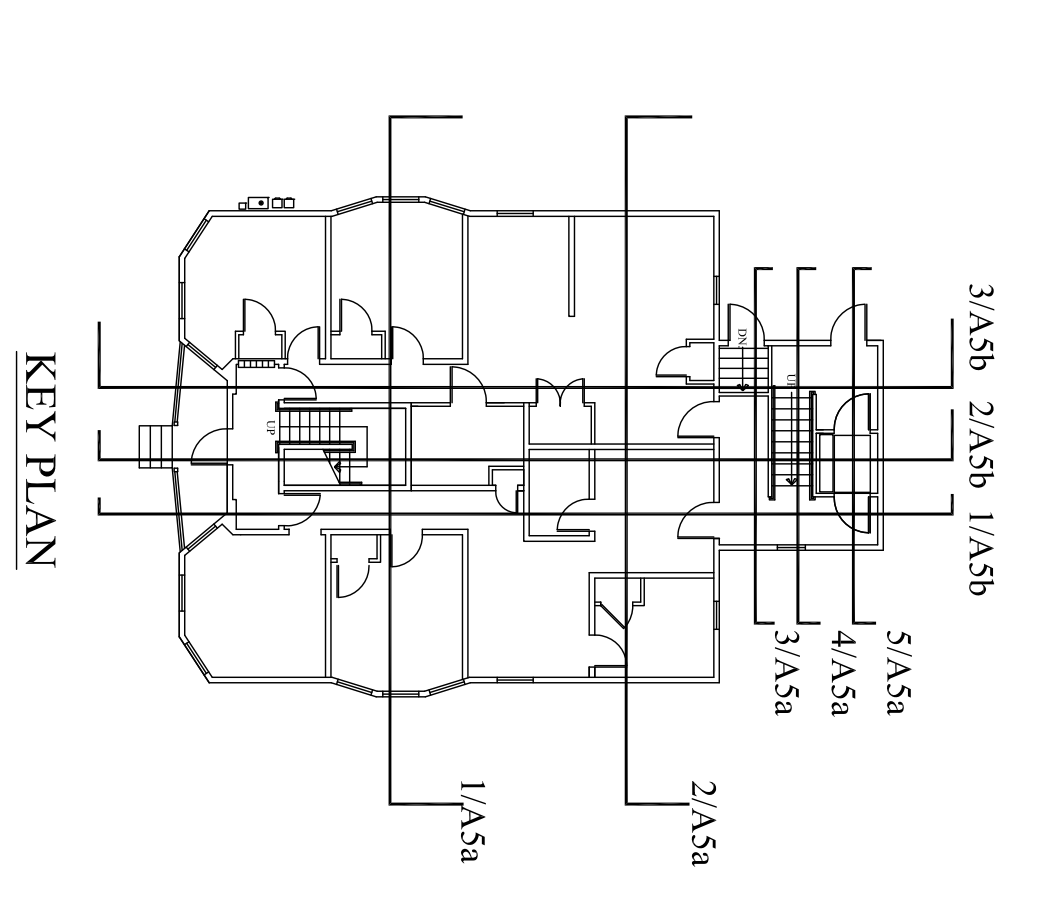
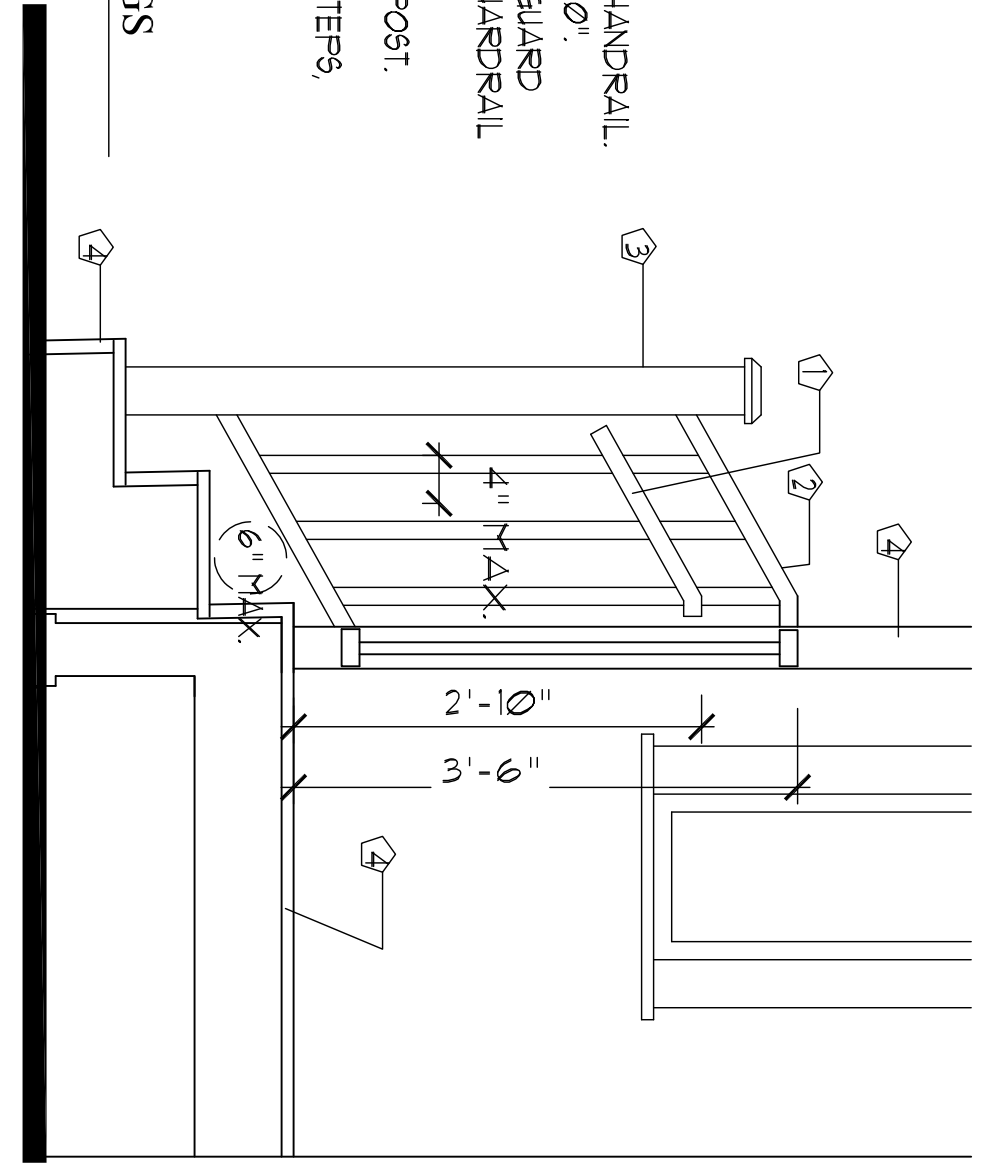

- LEGEND
- DOOR KEY 1
- KEYED NOTES
- 1 REFER TO LIFT SUBMITTAL FOR HEIGHT OF WALL - COORDINATE WITH ARCHITECT
 - 2 SPRAY FOAM INSULATION OMITTED WHERE NOT USED.
 - 3 SPRAY FOAM INSULATION OMITTED WHERE NOT USED.
 - 4 BASEMENT WALL SPRAY FOAM INSULATION OMITTED FOR CLARITY.
 - 5 SPRAY FOAM INSULATION & FIRE BARRIER
 - 6 NOT USED.

- 7 REFRIG. & REDECK TO MATCH EXISTING AT LOCATIONS OF DEMOLISHED CHIMNEY, UNSCREENING.
- 8 EXISTING GB. CEILINGS - PATCH, AIR SEAL, TAPE & FINISH TO MAINTAIN UNINTERRUPTED GB. FINISH.
- 9 EXISTING PORCH ROOF RAILINGS STEPS, COLUMNS, DECKING & STRUCTURE TO REMAIN.
- 10 INSTALL GUARDRAILS & HANDRAILS AT EXISTING PORCH STEPS. SEE DETAIL A.

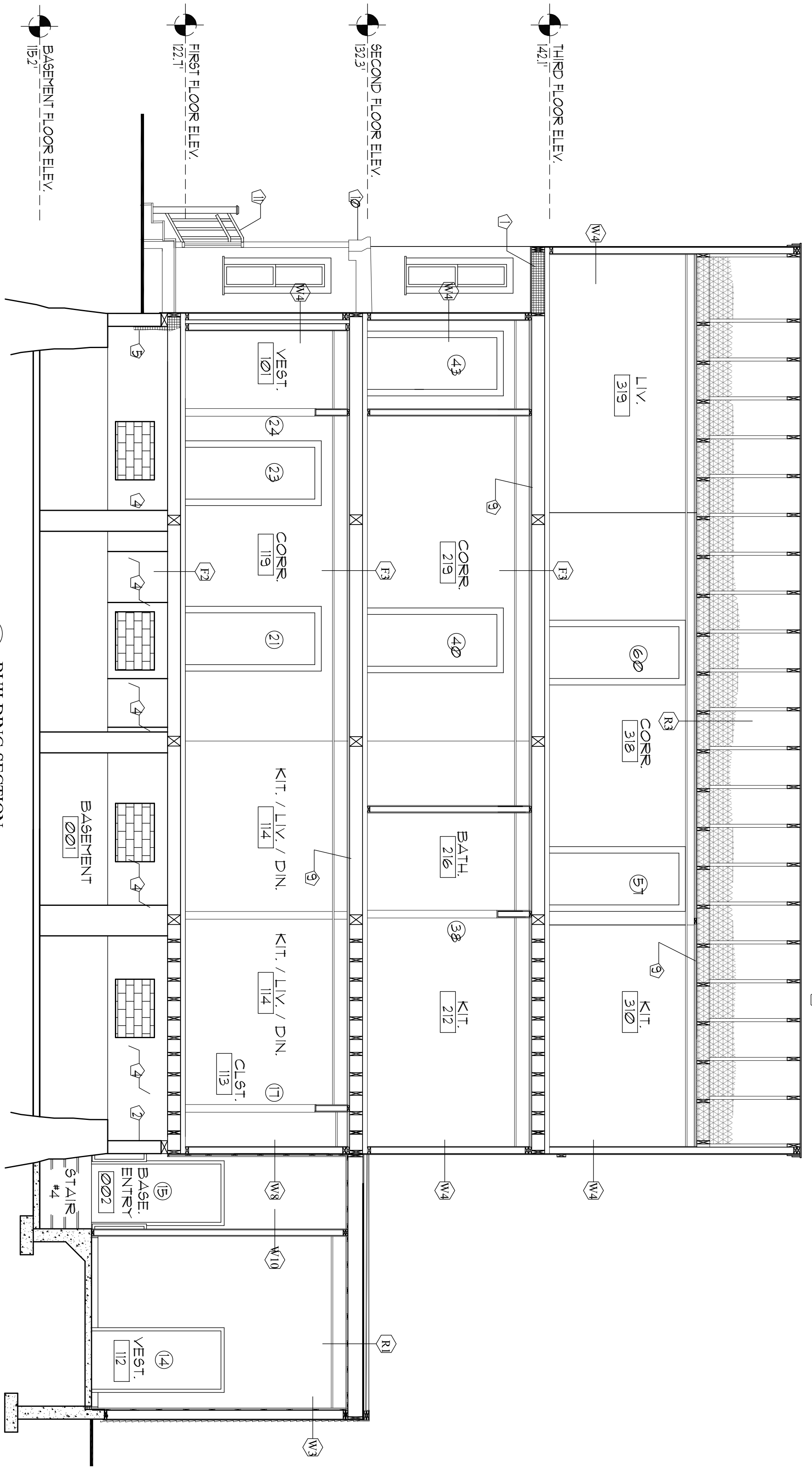

3 BUILDING SECTION
1/4" = 1'-0"