

CONDENSING COMMERCIAL GAS WATER HEATERS



SMART SYSTEM™

OPERATING CONTROL FEATURING
A BUILT-IN CASCADING SEQUENCER

8 MODELS FROM 150,000 TO
800,000 BTU/HR

FIRING RATE MODULATION TO 5:1

LESS THAN 20 ppm NO_x

DIRECT-VENT FLEXIBILITY TO 100 FEET



96%
THERMAL EFFICIENCY



Lochinvar.com

ARMOR[®]

CONDENSING WATER HEATER

A BETTER WAY TO ACHIEVE 96% THERMAL EFFICIENCY

ARMOR is a fully condensing commercial gas water heater. Available in eight models with inputs ranging from 150,000 to 800,000 Btu/hr, the ARMOR achieves thermal efficiencies up to 96%.

SEPARATE TANK FOR FLEXIBILITY, LOWER REPLACEMENT COSTS

With standard tank-type water heaters, your choices are limited when it comes to matching input with storage capacity to meet “peak demand” delivery requirements. With ARMOR, you can match one or more water heaters with inputs ranging from 150,000 to 800,000 with one or more storage tanks in a wide variety of sizes. Lochinvar Lock-Temp[®] tanks are available to meet the need, from our 80-gallon vertical to the 5000-gallon vertical or horizontal model. Another advantage of the ARMOR “dual component” system is lower replacement costs. Standard tank-type designs require replacement of the entire water heater. With ARMOR, you’ll save time and money by only replacing individual components as needed, such as the pump or storage tank.



AW (286-801)

FULLY MODULATING WITH 5:1 TURNDOWN

ARMOR features advanced Negative Regulation (Neg/Reg) sealed combustion technology, permitting fan speed to constantly adjust the volume of fuel and air entering the burner. This ensures that ARMOR can safely and reliably operate with supply gas pressure as low as 4 inches water column.

ARMOR is equipped with fully modulating combustion with 5:1 turndown. This means ARMOR can fire as low as 20% of maximum input when water heating demand is lowest, and increase the firing rate up to 100% as demand increases. The result is better overall efficiency and less cycling, compared to all other tank-type units which are “on-off,” which means they can only fire at 100% of maximum input.

STAINLESS STEEL CONDENSING HEAT EXCHANGER

The ARMOR's stainless steel heat exchanger is built to ASME Section IV requirements. Its design provides superior resistance to corrosion caused by condensation from low entering water temperatures. Traditional commercial water heaters will fail early with low entering water temperatures; however, with the ARMOR the lower the supply water temperature the more efficiently it performs throughout the life of the heater.



DIRECT-VENTING UP TO 100 FEET



Sidewall Vent Termination

ARMOR offers 7 venting options and tremendous flexibility for placement of units within the building, because it permits direct-vent air intake and exhaust runs up to 100 equivalent feet using either PVC, CPVC, Polypropylene or AL29-4C stainless steel vent pipe. Intake and exhaust runs can terminate horizontally through a sidewall or vertically through the roof.

**Optional Concentric Vent Kit Sold Separately (for 151-601 Models)*

FACTORY SUPPLIED AND SHIPPED STANDARD WITH EVERY MODEL



SMART SYSTEM

THE ULTIMATE WATER HEATER OPERATING CONTROL WITH GRAPHIC LCD DISPLAY

COMPATIBILITY WITH COPPER-FIN II™ NON-CONDENSING WATER HEATER TO CREATE A FRONT END LOADING SYSTEM

WATER HEATERS WITH DIFFERENT INPUTS CAN BE CASCADED TOGETHER TO MAXIMIZE TURNDOWN CAPABILITY

NIGHT SETBACK CAPABILITIES

- > SETBACK OF STORAGE TANK TEMP
- > SETBACK OF BUILDING RECIRCULATING TEMPERATURE*

WATER HEATER PUMP CONTROL:

- > PUMP DELAY WITH FREEZE PROTECTION
- > BUILDING RECIRCULATION PUMP CONTROL*
- > PUMP EXERCISE

HIGH-VOLTAGE TERMINAL STRIP:

- > 110 VAC INPUT TO WATER HEATER
- > DRY CONTACTS FOR WATER HEATER PUMP CONTROL
- > DRY CONTACTS FOR BUILDING RECIRC. PUMP CONTROL*

LOW-VOLTAGE TERMINAL STRIP

- WITH 28 POINTS OF CONNECTION
- > 0-10V WATER HEATER RATE OUTPUT
- > 0-10V HEAT DEMAND INPUT
- > MODBUS CONTACTS

USB CONNECTION POINT FOR OPTIONAL SMART SYSTEM PC SOFTWARE WITH ADVANCED SETUP AND DIAGNOSTICS

MODBUS COMPATIBILITY (OPTIONAL)

* EXCLUSIVE TO LOCHINVAR SMART SYSTEM



LONG-LASTING "LIFE CYCLE" EFFICIENCY

In a standard tank-type water heater, lime scale builds up over time on important heat transfer surfaces, insulating the water from the heat source. This decreases thermal efficiency and increases operating cost. Just 1/4" of lime scale can increase operating costs as much as 25%! This buildup in the bottom of the tank and around the flue tubes can cause tank-type heaters to fail in as little as 2-3 years.

ARMOR's "dual component" concept eliminates the impact of lime scale, maintaining a high-rated thermal efficiency and low operating cost throughout its long life cycle.

The chart below illustrates how ARMOR is a better way, delivering true "life cycle efficiency" compared to standard tank-type units.



Traditional tank-type water heater flue tubes with nearly 6" of lime scale buildup

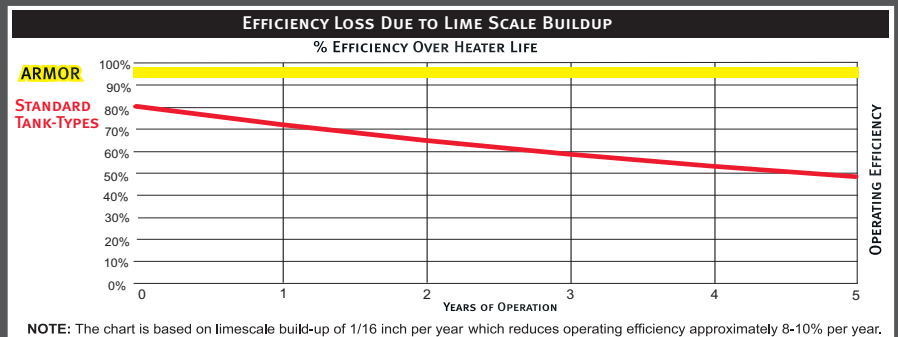

FLEXIBLE VENTING OPTIONS - Up to 100 feet of air intake and 100 feet of exhaust vent with PVC, CPVC, Polypropylene or SS.

Direct Vent Sidewall



Direct Vent Vertical



Room Air Sidewall

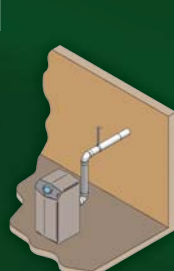

Room Air Vertical



Vertical w/Sidewall Air



Concentric Direct Vent Sidewall*



Concentric Direct Vent Vertical*

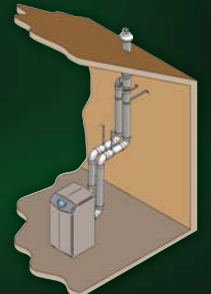

ARMOR™ WATER HEATER DIMENSIONS AND SPECIFICATIONS

MODELS 151 & 200

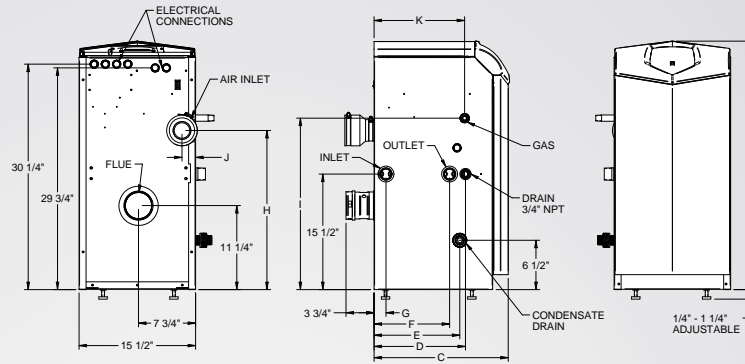

MODELS 286-801

Model Number Guide

AW	N	151	PM
Model	Natural Gas	Btu/hr Input	Pump Mount

Armor Water Heater,
Natural Gas,
150,000 Btu/hr Input,
Pump Mount

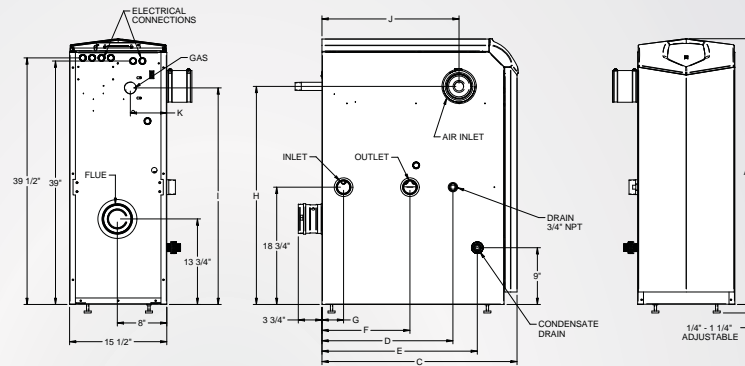

Model Number	Btu/hr Input	GPH @ 100° Rise	A	C	D	E	F	G	H	I	J	K	Gas Conn.	Water Conn.	Air Inlet	Vent Size	Shipping Wt. (lbs.)
AWN151PM	150,000	175	33 1/4"	18"	12 1/4"	11 1/2"	10"	1 1/2"	21 1/4"	23"	1 3/4"	12"	1/2"	1 1/4"	3"	3"	165
AWN200PM	199,999	233	33 1/4"	22 1/4"	16 1/2"	15 3/4"	14 1/4"	5 1/4"	21 1/4"	23"	1 3/4"	16 1/4"	1/2"	1 1/4"	3"	3"	181
AWN286PM	285,000	332	42 1/2"	19 3/4"	12 3/4"	13 1/2"	6"	2"	34"	31"	11 3/4"	4 1/4"	3/4"	2"	4"	4"	236
AWN400PM	399,999	466	42 1/2"	27"	21"	20 3/4"	14"	3 1/2"	34"	34"	18 3/4"	2"	1"	2"	4"	4"	306
AWN501PM	500,000	582	42 1/2"	31 1/2"	21"	25"	14"	3 1/2"	35"	35"	22"	5 3/4"	1"	2"	4"	4"	339
AWN601PM	600,000	699	42 1/2"	36 1/4"	25"	21"	14"	3 1/2"	36"	32 3/4"	19 1/2"	5 1/2"	1"	2"	4"	4"	380
AWN701PM	700,000	815	42 1/2"	40 1/4"	29"	23"	17"	3 1/2"	36"	32 3/4"	23 1/2"	3 1/4"	1"	2"	4"	6"	461
AWN801PM	800,000	931	42 1/2"	45 1/4"	33 1/4"	23"	17"	3 1/2"	36"	32 3/4"	27 3/4"	3 1/4"	1"	2"	4"	6"	527

STANDARD FEATURES

- > 96% Thermal Efficiency (AHRI Certified)
- > Modulating Burner with 5:1 Turndown
 - > Direct-Spark Ignition
 - > Low NOx Operation
 - > Sealed Combustion
 - > Low Gas Pressure Operation
- > Vertical & Horizontal Direct-Vent
 - > PVC, CPVC, Polypropylene or SS up to 100 Feet
 - > PVC/CPVC Sidewall Vent Termination
- > Stainless Steel Heat Exchanger
 - > All Welded Construction, Gasketless Design
 - > 160 psi Working Pressure
 - > ASME Construction (AW 286-801)
- > Natural to L.P. Conversion Kit
- > All Bronze Circulating Pump
- > On/Off Switch
- > Flow Switch
- > ASME Temperature & Pressure Relief Valve (286-801)
- > Temperature & Pressure Gauge (AW 501-801)
- > Downstream Test Valves (AW 501-801)
- > Adjustable Leveling Legs
- > Tank Sensor
- > Adjustable High Limit w/ Manual Reset
- > Automatic Reset High Limit
- > Condensate Trap
- > Zero Clearances to Combustible Material
- > 5 Year Limited Warranty (See Warranty for Details)
- > 1 Year Parts Warranty (See Warranty for Details)

SMART SYSTEM FEATURES

- > SMART SYSTEM Digital Operating Control
 - > Multi Color Graphic LCD Display
- > Built in Cascading Sequencer for up to 8 Water Heaters
 - > Multiple Size Water Heater Cascade
 - > Lead Lag
 - > Efficiency Optimization
 - > Front-End Loading Capability with CopperFin II
- > Building Management System Integration
 - > Modbus Communication (Optional)
 - > 0-10 VDC Input to Control Modulation or Set point
 - > 0-10 VDC Modulation Rate Output
 - > 0-10 VDC Input to Enable/Disable call for heat
- > Access to BMS Settings Through Graphic LCD Display
- > Low Water Flow Safety Control & Indication
- > Inlet & Outlet Temperature Sensors & Readout
- > Flue Temperature Sensor
- > Water Heater Pump Control
- > Pump Delay with Freeze Protection
- > Pump Exercise
- > Night Setback
- > Building Recirculation Loop Pump Control*
 - > Night Setback of Building Recirculation Loop*
- > Time Clock
- > Maintenance Reminder
 - > Ability to program installer name and number into the product as service contact

*Exclusive to Lochinvar

High Voltage Terminal Strip

- > 120 VAC / 60 Hertz / 1 Phase Power Supply
- > Pump Control Contacts
- > Water Heater Pump Control Contacts
- > Building Recirculation Pump Control Contacts

Low Voltage Terminal Strip

- > 24 VAC Auxiliary Device Relay
- > Auxiliary Proving Switch Contacts
- > Flow Switch Contacts
- > Alarm on Any Failure Contacts
- > Runtime Contacts
- > Tank Sensor Contacts
- > Cascade Contacts
- > 0-10 VDC BMS External Control Contact
- > 0-10 VDC Boiler Rate Output Contacts

FIRING CONTROL SYSTEMS

- > M9 Standard Construction
- > M7 California Code (AW 286-801)

OPTIONAL EQUIPMENT

- > Alarm Bell
- > Condensate Neutralization Kit
- > High & Low Gas Pressure Switches (AW 501-801)
- > Concentric Vent Kit (3" & 4" PVC/CPVC only)
- > BMS Gateway to LON or BacNet
- > ModBus Communications
- > SMART SYSTEM PC Software
- > Room Air Vent Kits
- > Stack Frame



Lochinvar, LLC
300 Maddox Simpson Parkway
Lebanon, Tennessee 37090
P: 615-889-8900 / F: 615-547-1000
www.Lochinvar.com

