

HOOD INFORMATION - Job#2906831														
HOOD NO.	TAG	MODEL	LENGTH	MAX. COOKING TEMP.	TOTAL EXH. CFM	EXHAUST SYSTEM	EXHAUST SYSTEM	EXHAUST SYSTEM	EXHAUST SYSTEM	EXHAUST SYSTEM	EXHAUST SYSTEM	EXHAUST SYSTEM	EXHAUST SYSTEM	EXHAUST SYSTEM
1		S44	14'-00"	400	3000	2408	400	53	ALONE	ALONE				

HOOD INFORMATION - Job#2906831														
HOOD NO.	TAG	TYPE	HTY	LENGTH	EFFICIENCY # 9	HTY	TYPE	WIRE GAUGE	LOCATION	SIZE	TYPE	SIZE	MODEL #	QUANTITY
1		Caprate Solo Filter	30"	20"	16"	92%	See Filter Spec.	4	Screw In Compact	NO				

HOOD OPTIONS													
HOOD NO.	TAG	OPTION											
1		FIELD WRAPPER 1800" High Front, Left, Right											
		BACKSPLASH 1800" High x 1800" Long 430 SS Vertical											
		INDIATOR FOR BACK OF HOOD											
		RIGHT VERTICAL END PANEL 27" Top Width, 27" Bottom Width, 80" High Insulated 430 SS											
		LEFT VERTICAL END PANEL 27" Top Width, 27" Bottom Width, 80" High Insulated 430 SS											

PREPARED SUPPLY PLENUM(S)													
PLENUM NO.	TAG	POS.	LENGTH	WIDTH	HEIGHT	TYPE	WIDTH	LENGTH	AREA	S.P.			
1		Front	168"	16"	6"	M.A.	12"	20"	802	0.027"			

SPECIFICATION CAPTRATE GREASE-STOP SOLID FILTER
 THE CAPTRATE GREASE-STOP SOLID FILTER IS A SINGLE-STAGE FILTER FEATURING A UNIQUE 5-BAFFLE DESIGN IN CONJUNCTION WITH A SLOTTED REAR BAFFLE DESIGN TO DELIVER EXCEPTIONAL FILTRATION EFFICIENCY.
 FILTER IS STAINLESS STEEL CONSTRUCTION, AND SIZED TO FIT INTO STANDARD 2-INCH DEEP HOOD CHANNELS.
 UNITS SHALL INCLUDE STAINLESS STEEL HANDLES AND A FASTENING DEVICE TO SECURE THE TWO COMPONENTS WHEN CHANNELS.
 GREASE EXTRACTION EFFICIENCY PERFORMANCE SHALL REMOVE AT LEAST 75% OF GREASE PARTICLES FIVE INCHES IN SIZE, AND 90% GREASE PARTICLES SEVEN INCHES IN SIZE AND LARGER, WITH A CORRESPONDING PRESSURE DROP NOT TO EXCEED 10 INCHES OF WATER GAUGE.
 THE CAPTRATE GREASE-STOP SOLID WAS TESTED TO ASTM STANDARD ASTM F2519-05.

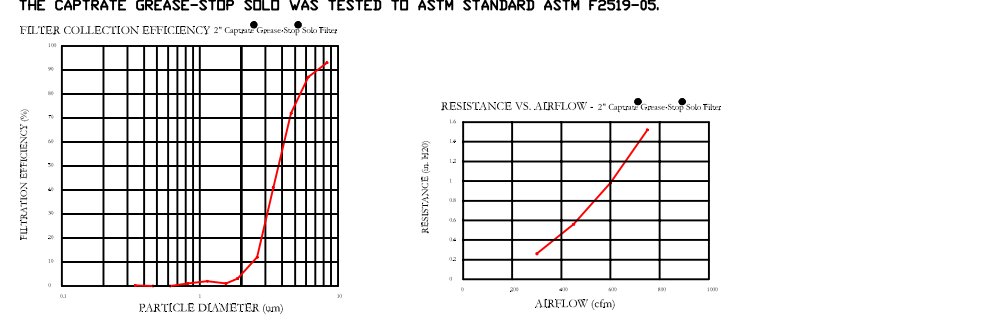

CAPTRATE FILTERS ARE BUILT IN COMPLIANCE WITH:
 NSF STANDARD NO. 2
 UL STANDARD 8946
 INT. MECH. CODE CMCA
 UL-5099

CUSTOMER APPROVAL TO MANUFACTURE:

Approved as Noted

Approved with NO Exception Taken

Revised and Resubmit

Signature _____ Date _____

Signature _____ Date _____

JOB: Little Giant r4
 LOCATION: PORTLAND, ME, 04102
 DATE: 2/10/2017 JOB #: 2906831
 DWG #: 1 DRAWN BY: BFC-21
 REV: SCALE: 3/8" = 1'-0"

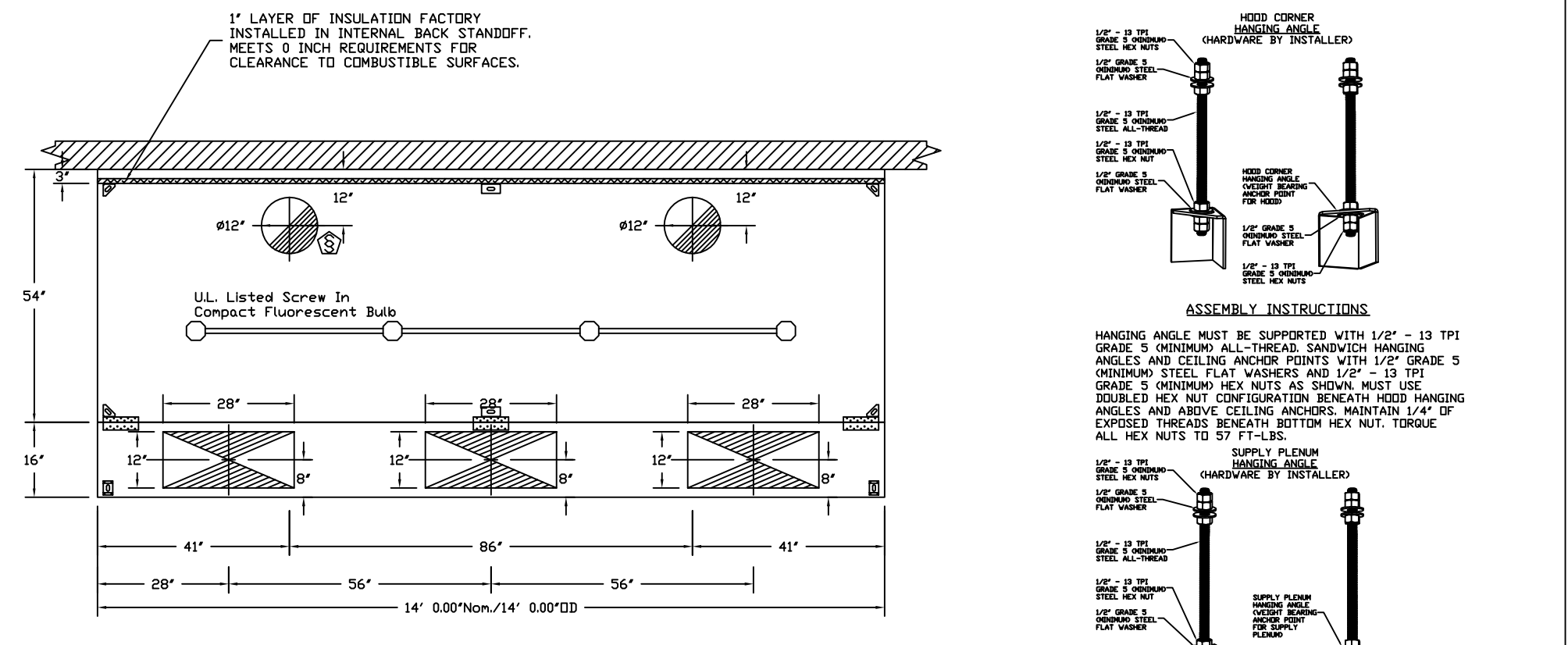

PLAN VIEW - Hood #1
 14' 0.00' LONG 542ND-2-PSP-F
 NOTE: Additional hanging angles provided for hoods 12' and longer.

CUSTOMER APPROVAL TO MANUFACTURE:

Approved as Noted

Approved with NO Exception Taken

Revised and Resubmit

Signature _____ Date _____

Signature _____ Date _____

JOB: Little Giant r4
 LOCATION: PORTLAND, ME, 04102
 DATE: 2/10/2017 JOB #: 2906831
 DWG #: 2 DRAWN BY: BFC-21
 REV: SCALE: 3/8" = 1'-0"

DuctWork #1 Parts - Job#2906831													
Part #	QTY	SP	Length	Velocity	HTY	Description							
FD	1	EXHAUST	1500	1500	210	Single Wall Duct 15" Dia. Color - 18" Diameter Duct - 15" Pitch.							
ASSEMBLY #101	1	ASSEMBLY	1500	1500	210	Single Wall Duct 15" Dia. Assembly.							
FD	1	EXHAUST	1500	1500	210	Single Wall Duct 15" Dia. Color - 18" Diameter Duct - 15" Pitch.							
ASSEMBLY #102	1	ASSEMBLY	1500	1500	210	Single Wall Duct 15" Dia. Assembly.							
FD	1	EXHAUST	1500	1500	210	Single Wall Duct 15" Dia. Color - 18" Diameter Duct - 15" Pitch.							
ASSEMBLY #103	1	ASSEMBLY	1500	1500	210	Single Wall Duct 15" Dia. Assembly.							
FD	1	EXHAUST	1500	1500	210	Single Wall Duct 15" Dia. Color - 18" Diameter Duct - 15" Pitch.							
ASSEMBLY #104	1	ASSEMBLY	1500	1500	210	Single Wall Duct 15" Dia. Assembly.							
FD	1	EXHAUST	1500	1500	210	Single Wall Duct 15" Dia. Color - 18" Diameter Duct - 15" Pitch.							
ASSEMBLY #105	1	ASSEMBLY	1500	1500	210	Single Wall Duct 15" Dia. Assembly.							
FD	1	EXHAUST	1500	1500	210	Single Wall Duct 15" Dia. Color - 18" Diameter Duct - 15" Pitch.							
ASSEMBLY #106	1	ASSEMBLY	1500	1500	210	Single Wall Duct 15" Dia. Assembly.							
FD	1	EXHAUST	1500	1500	210	Single Wall Duct 15" Dia. Color - 18" Diameter Duct - 15" Pitch.							
ASSEMBLY #107	1	ASSEMBLY	1500	1500	210	Single Wall Duct 15" Dia. Assembly.							
FD	1	EXHAUST	1500	1500	210	Single Wall Duct 15" Dia. Color - 18" Diameter Duct - 15" Pitch.							
ASSEMBLY #108	1	ASSEMBLY	1500	1500	210	Single Wall Duct 15" Dia. Assembly.							
FD	1	EXHAUST	1500	1500	210	Single Wall Duct 15" Dia. Color - 18" Diameter Duct - 15" Pitch.							
ASSEMBLY #109	1	ASSEMBLY	1500	1500	210	Single Wall Duct 15" Dia. Assembly.							
FD	1	EXHAUST	1500	1500	210	Single Wall Duct 15" Dia. Color - 18" Diameter Duct - 15" Pitch.							
ASSEMBLY #110	1	ASSEMBLY	1500	1500	210	Single Wall Duct 15" Dia. Assembly.							
FD	1	EXHAUST	1500	1500	210	Single Wall Duct 15" Dia. Color - 18" Diameter Duct - 15" Pitch.							
ASSEMBLY #111	1	ASSEMBLY	1500	1500	210	Single Wall Duct 15" Dia. Assembly.							
FD	1	EXHAUST	1500	1500	210	Single Wall Duct 15" Dia. Color - 18" Diameter Duct - 15" Pitch.							
ASSEMBLY #112	1	ASSEMBLY	1500	1500	210	Single Wall Duct 15" Dia. Assembly.							
FD	1	EXHAUST	1500	1500	210	Single Wall Duct 15" Dia. Color - 18" Diameter Duct - 15" Pitch.							
ASSEMBLY #113	1	ASSEMBLY	1500	1500	210	Single Wall Duct 15" Dia. Assembly.							
FD	1	EXHAUST	1500	1500	210	Single Wall Duct 15" Dia. Color - 18" Diameter Duct - 15" Pitch.							
ASSEMBLY #114	1	ASSEMBLY	1500	1500	210	Single Wall Duct 15" Dia. Assembly.							
FD	1	EXHAUST	1500	1500	210	Single Wall Duct 15" Dia. Color - 18" Diameter Duct - 15" Pitch.							
ASSEMBLY #115	1	ASSEMBLY	1500	1500	210	Single Wall Duct 15" Dia. Assembly.							
FD	1	EXHAUST	1500	1500	210	Single Wall Duct 15" Dia. Color - 18" Diameter Duct - 15" Pitch.							
ASSEMBLY #116	1	ASSEMBLY	1500	1500	210	Single Wall Duct 15" Dia. Assembly.							
FD	1	EXHAUST	1500	1500	210	Single Wall Duct 15" Dia. Color - 18" Diameter Duct - 15" Pitch.							
ASSEMBLY #117	1	ASSEMBLY	1500	1500	210	Single Wall Duct 15" Dia. Assembly.							
FD	1	EXHAUST	1500	1500	210	Single Wall Duct 15" Dia. Color - 18" Diameter Duct - 15" Pitch.							
ASSEMBLY #118	1	ASSEMBLY	1500	1500	210	Single Wall Duct 15" Dia. Assembly.							
FD	1	EXHAUST	1500	1500	210	Single Wall Duct 15" Dia. Color - 18" Diameter Duct - 15" Pitch.							
ASSEMBLY #119	1	ASSEMBLY	1500	1500	210	Single Wall Duct 15" Dia. Assembly.							
FD	1	EXHAUST	1500	1500	210	Single Wall Duct 15" Dia. Color - 18" Diameter Duct - 15" Pitch.							
ASSEMBLY #120	1	ASSEMBLY	1500	1500	210	Single Wall Duct 15" Dia. Assembly.							
FD	1	EXHAUST	1500	1500	210	Single Wall Duct 15" Dia. Color - 18" Diameter Duct - 15" Pitch.							
ASSEMBLY #121	1	ASSEMBLY	1500	1500	210	Single Wall Duct 15" Dia. Assembly.							
FD	1	EXHAUST	1500	1500	210	Single Wall Duct 15" Dia. Color - 18" Diameter Duct - 15" Pitch.							
ASSEMBLY #122	1	ASSEMBLY	1500	1500	210	Single Wall Duct 15" Dia. Assembly.							
FD	1	EXHAUST	1500	1500	210	Single Wall Duct 15" Dia. Color - 18" Diameter Duct - 15" Pitch.							
ASSEMBLY #123	1	ASSEMBLY	1500	1500	210	Single Wall Duct 15" Dia. Assembly.							
FD	1	EXHAUST	1500	1500	210	Single Wall Duct 15" Dia. Color - 18" Diameter Duct - 15" Pitch.							
ASSEMBLY #124	1	ASSEMBLY	1500	1500	210	Single Wall Duct 15" Dia. Assembly.							
FD	1	EXHAUST	1500	1500	210	Single Wall Duct 15" Dia. Color - 18" Diameter Duct - 15" Pitch.							
ASSEMBLY #125	1	ASSEMBLY	1500	1500	210	Single Wall Duct 15" Dia. Assembly.							
FD	1	EXHAUST	1500	1500	210	Single Wall Duct 15" Dia. Color - 18" Diameter Duct - 15" Pitch.							
ASSEMBLY #126	1	ASSEMBLY	1500	1500	210	Single Wall Duct 15" Dia. Assembly.							
FD	1	EXHAUST	1500	1500	210	Single Wall Duct 15" Dia. Color - 18" Diameter Duct - 15" Pitch.							
ASSEMBLY #127	1	ASSEMBLY	1500	1500	210	Single Wall Duct 15" Dia. Assembly.							
FD	1	EXHAUST	1500	1500	210	Single Wall Duct 15" Dia. Color - 18" Diameter Duct - 15" Pitch.							
ASSEMBLY #128	1	ASSEMBLY	1500	1500	210	Single Wall Duct 15" Dia. Assembly.							
FD	1	EXHAUST	1500	1500	210	Single Wall Duct 15" Dia. Color - 18" Diameter Duct - 15" Pitch.							
ASSEMBLY #129	1	ASSEMBLY	1500	1500	210	Single Wall Duct 15" Dia. Assembly.							
FD	1	EXHAUST	1500	1500	210	Single Wall Duct 15" Dia. Color - 18" Diameter Duct - 15" Pitch.							
ASSEMBLY #130	1	ASSEMBLY	1500	1500	210	Single Wall Duct 15" Dia. Assembly.							
FD	1	EXHAUST	1500	1500	210	Single Wall Duct 15" Dia. Color - 18" Diameter Duct - 15" Pitch.							
ASSEMBLY #131	1	ASSEMBLY	1500	1500	210	Single Wall Duct 15" Dia. Assembly.							
FD	1	EXHAUST	1500	1500	210	Single Wall Duct 15" Dia. Color - 18" Diameter Duct - 15" Pitch.							
ASSEMBLY #132	1	ASSEMBLY	1500	1500	210	Single Wall Duct 15" Dia. Assembly.							
FD	1	EXHAUST	1500	1500	210	Single Wall Duct 15" Dia. Color - 18" Diameter Duct - 15" Pitch.							
ASSEMBLY #133	1	ASSEMBLY	1500	1500	210	Single Wall Duct 15" Dia. Assembly.							
FD	1	EXHAUST	1500	1500	210	Single Wall Duct 15" Dia. Color - 18" Diameter Duct - 15" Pitch.							
ASSEMBLY #134	1	ASSEMBLY	1500	1500	210	Single Wall Duct 15" Dia. Assembly.							
FD	1	EXHAUST	1500	1500	210	Single Wall Duct 15" Dia. Color - 18" Diameter Duct - 15" Pitch.							
ASSEMBLY #135	1	ASSEMBLY	1500	1500	210	Single Wall Duct 15" Dia. Assembly.							
FD	1	EXHAUST	1500	1500	210	Single Wall Duct 15" Dia. Color - 18" Diameter Duct - 15" Pitch.							
ASSEMBLY #136	1	ASSEMBLY	1500	1500	210	Single Wall Duct 15" Dia. Assembly.							
FD	1	EXHAUST	1500	1500	210	Single Wall Duct 15" Dia. Color - 18" Diameter Duct - 15" Pitch.							
ASSEMBLY #137	1	ASSEMBLY	1500	1500	210	Single Wall Duct 15" Dia. Assembly.							
FD	1	EXHAUST	1500	1500	210	Single Wall Duct 15" Dia. Color - 18" Diameter Duct - 15" Pitch.							
ASSEMBLY #138	1	ASSEMBLY	1500	1500	210	Single Wall Duct 15" Dia. Assembly.							
FD	1	EXHAUST	1500	1500	210	Single Wall Duct 15" Dia. Color - 18" Diameter Duct - 15" Pitch.							
ASSEMBLY #139	1	ASSEMBLY	1500	1500	210	Single Wall Duct 15" Dia. Assembly.							
FD	1	EXHAUST	1500	1500	210	Single Wall Duct 15" Dia. Color - 18" Diameter Duct - 15" Pitch.							
ASSEMBLY #140	1	ASSEMBLY	1500	1500	210	Single Wall Duct 15" Dia. Assembly.							
FD	1	EXHAUST	1500	1500	210	Single Wall Duct 15" Dia. Color - 18" Diameter Duct - 15" Pitch.							
ASSEMBLY #141	1	ASSEMBLY	1500	1500	210	Single Wall Duct 15" Dia. Assembly.							
FD	1	EXHAUST	1500	1500	210	Single Wall Duct 15" Dia. Color - 18" Diameter Duct - 15" Pitch.							
ASSEMBLY #142	1	ASSEMBLY	1500	1500	210	Single Wall Duct 15" Dia. Assembly.							
FD	1	EXHAUST	1500	1500	210	Single Wall Duct 15" Dia. Color - 18" Diameter Duct - 15" Pitch.							
ASSEMBLY #143	1	ASSEMBLY	1500	1500	210	Single Wall Duct 15" Dia. Assembly.							
FD	1	EXHAUST	1500	1500	210	Single Wall Duct 15" Dia. Color - 18" Diameter Duct - 15" Pitch.							
ASSEMBLY #144	1	ASSEMBLY	1500	1500	210	Single Wall Duct 15" Dia. Assembly.							
FD	1	EXHAUST	1500	1500	210	Single Wall Duct 15" Dia. Color - 18" Diameter Duct - 15" Pitch.							
ASSEMBLY #145	1	ASSEMBLY	1500	1500	210	Single Wall Duct 15" Dia. Assembly.							
FD	1	EXHAUST	1500	1500	210	Single Wall Duct 15" Dia. Color - 18" Diameter Duct - 15" Pitch.							
ASSEMBLY #146	1	ASSEMBLY	1500	1500	210	Single Wall Duct 15" Dia. Assembly.							
FD	1	EXHAUST	1500	1500	210	Single Wall Duct 15" Dia. Color - 18" Diameter Duct - 15" Pitch.							
ASSEMBLY #147	1	ASSEMBLY	1500	1500	210	Single Wall Duct 15" Dia. Assembly.							
FD	1	EXHAUST	1500	1500	210	Single Wall Duct 15" Dia. Color - 18" Diameter Duct - 15" Pitch.							
ASSEMBLY #148	1	ASSEMBLY	1500	1500	210	Single Wall Duct 15" Dia. Assembly.							
FD	1	EXHAUST	1500	1500	210	Single Wall Duct 15" Dia. Color - 18" Diameter Duct - 15" Pitch.							
ASSEMBLY #149	1	ASSEMBLY	1500	1500	210	Single Wall Duct 15" Dia. Assembly.							
FD	1	EXHAUST	1500	1500	210	Single Wall Duct 15" Dia. Color - 18" Diameter Duct - 15" Pitch.							
ASSEMBLY #150	1	ASSEMBLY	1500	1500	210	Single Wall Duct 15" Dia. Assembly.							

CUSTOMER APPROVAL TO MANUFACTURE:

Approved as Noted

Approved with NO Exception Taken

Revised and Resubmit

Signature _____ Date _____

Signature _____ Date _____

JOB: Little Giant r4
 LOCATION: PORTLAND, ME, 04102
 DATE: 2/10/2017 JOB #: 2906831
 DWG #: 3 DRAWN BY: BFC-21
 REV: SCALE: 3/8" = 1'-0"

HOOD SYSTEM INFORMATION

HOOD PLAN VIEW

DUCTWORK MATERIALS

EXHAUST FAN INFORMATION - Job#2906831													
FAN NO.	TAG	FAN UNIT MODEL #	CFM	ESP.	RPM	HP	BAFF.	#	VOLT.	FLA	WEIGHT (LBS)	CODES	
1		SUB99FA	3000	1500	1864	3.000	1E4W	3	208	9.5	152	192	

MIA FAN INFORMATION - Job#2906831																
FAN NO.	TAG	FAN UNIT MODEL #	BLOWER	HOUSING	MIN. CFM	DESIGN CFM	ESP.	RPM	HP	BAFF.	#	VOLT.	FLA	WEIGHT (LBS)	CODES	BURNER EFFICIENCY
2		AI-8250-G0	G10	AI-8250	1000	1200	1200	1200	6.000	12600	3	208	5.5	700	22	92

GAS FIRING MAKE-UP AIR UNITS													
FAN UNIT NO.	TAG	INPUT BTU/h	INPUT BTU/h	TEMP. RISE	REQUIRED INPUT PRESSURE	GAS TYPE							
2													