

**DISPLAY THIS CARD ON PRINCIPAL FRONTAGE OF WORK  
CITY OF PORTLAND**

Please Read  
Application And  
Notes, If Any,  
Attached

**BUILDING INSPECTION**

**PERMIT**

Permit Number **188977E**

**JUN 30 2008**

**CITY OF PORTLAND**

This is to certify that MAIER LYDIA F & MERRICK T HENNINGWAY/Pollard Builders /

has permission to Repair/replace rear steps

AT 98 CLARK ST

provided that the person or persons who accept this permit shall comply with all of the provisions of the Statutes of the State and of the Ordinances of the City of Portland regulating the construction, maintenance and use of buildings and structures, and of the application on file in this department.

Apply to Public Works for street line and grade if nature of work requires such information.

Notification of inspection must be given and when permission procured before this building or part thereof is altered or closed-in. 24 HOUR NOTICE IS REQUIRED.

A certificate of occupancy must be procured by owner before this building or part thereof is occupied.

**OTHER REQUIRED APPROVALS**

Fire Dept. \_\_\_\_\_

Health Dept. \_\_\_\_\_

Appeal Board \_\_\_\_\_

Other \_\_\_\_\_

Department Name

*Thomas M. Mally 6/30/08*  
Director - Building & Inspection Services

**PENALTY FOR REMOVING THIS CARD**

**City of Portland, Maine - Building or Use Permit Application**

389 Congress Street, 04101 Tel: (207) 874-8703, Fax: (207) 874-8716

Permit No: 08-0771	Issue Date:	CBL: 057 C033001
-----------------------	-------------	---------------------

Location of Construction: 98 CLARK ST	Owner Name: MAIER LYDIA F & MERRITT T	Owner Address: 98 CLARK ST	Phone:
Business Name:	Contractor Name: Pollard Builders / Ben Pollard	Contractor Address: 30 Eastern Promenade Portland	Phone: 2077765711
Lessee/Buyer's Name	Phone:	Permit Type: Alterations - Duplex	Zone: R7

Past Use: 2 Unit building	Proposed Use: 2 units building - Repair/ replace rear steps	Permit Fee: \$40.00	Cost of Work: \$2,000.00	CEO District: 2
		FIRE DEPT: <input type="checkbox"/> Approved <input type="checkbox"/> Denied	INSPECTION: Use Group: R3 Type: SB IRC 2003	

Proposed Project Description: Repair/ replace rear steps	Signature:	Signature: <i>jm 6/30/08</i>
PEDESTRIAN ACTIVITIES DISTRICT (P.A.D.)		
Action: <input type="checkbox"/> Approved <input type="checkbox"/> Approved w/Conditions <input type="checkbox"/> Denied		
Signature:		Date:

Permit Taken By: Idobson	Date Applied For: 06/27/2008	<b>Zoning Approval</b>		
-----------------------------	---------------------------------	------------------------	--	--

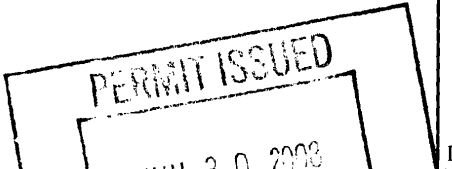
<p>1. This permit application does not preclude the Applicant(s) from meeting applicable State and Federal Rules.</p> <p>2. Building permits do not include plumbing, septic or electrical work.</p> <p>3. Building permits are void if work is not started within six (6) months of the date of issuance. False information may invalidate a building permit and stop all work..</p>	<p><b>Special Zone or Reviews</b></p> <input type="checkbox"/> Shoreland <input type="checkbox"/> Wetland <input type="checkbox"/> Flood Zone <input type="checkbox"/> Subdivision <input type="checkbox"/> Site Plan Maj <input type="checkbox"/> Minor <input type="checkbox"/> MM <input type="checkbox"/> Date: <i>6/30/08</i>	<p><b>Zoning Appeal</b></p> <input type="checkbox"/> Variance <input type="checkbox"/> Miscellaneous <input type="checkbox"/> Conditional Use <input type="checkbox"/> Interpretation <input type="checkbox"/> Approved <input type="checkbox"/> Denied Date:	<p><b>Historic Preservation</b></p> <input type="checkbox"/> Not in District or Landmark <input type="checkbox"/> Does Not Require Review <input type="checkbox"/> Requires Review <input checked="" type="checkbox"/> Approved <input type="checkbox"/> Approved w/Conditions <input type="checkbox"/> Denied Date: <i>6/30/08</i> Date: <i>for Deb A. jm</i>
			

**CERTIFICATION**

I hereby certify that I am the owner of record of the named property, or that the proposed work is authorized by the owner of record and that I have been authorized by the owner to make this application as his authorized agent and I agree to conform to all applicable laws of this jurisdiction. In addition, if a permit for work described in the application is issued, I certify that the code official's authorized representative shall have the authority to enter all areas covered by such permit at any reasonable hour to enforce the provision of the code(s) applicable to such permit.

\_\_\_\_\_  
SIGNATURE OF APPLICANT ADDRESS DATE PHONE

\_\_\_\_\_  
RESPONSIBLE PERSON IN CHARGE OF WORK, TITLE DATE PHONE

**City of Portland, Maine - Building or Use Permit**

389 Congress Street, 04101 Tel: (207) 874-8703, Fax: (207) 874-8716

<b>Permit No:</b> 08-0771	<b>Date Applied For:</b> 06/27/2008	<b>CBL:</b> 057 C033001
------------------------------	--	----------------------------

<b>Location of Construction:</b> 98 CLARK ST	<b>Owner Name:</b> MAIER LYDIA F & MERRITT T	<b>Owner Address:</b> 98 CLARK ST	<b>Phone:</b>
<b>Business Name:</b>	<b>Contractor Name:</b> Pollard Builders / Ben Pollard	<b>Contractor Address:</b> 30 Eastern Promenade Portland	<b>Phone</b> (207) 776-5711
<b>Lessee/Buyer's Name</b>	<b>Phone:</b>	<b>Permit Type:</b> Alterations - Duplex	

<b>Proposed Use:</b> 2 units building - Repair/ replace rear steps	<b>Proposed Project Description:</b> Repair/ replace rear steps
---	--

<b>Dept:</b> Zoning	<b>Status:</b> Approved with Conditions	<b>Reviewer:</b> Tom Markley	<b>Approval Date:</b> 06/30/2008
<b>Note:</b>			<b>Ok to Issue:</b> <input checked="" type="checkbox"/>
1) Stairs must be put back within the existing footprint.			
2) This permit is being approved on the basis of plans submitted. Any deviations shall require a separate approval before starting that work.			
<b>Dept:</b> Building	<b>Status:</b> Approved with Conditions	<b>Reviewer:</b> Tom Markley	<b>Approval Date:</b> 06/30/2008
<b>Note:</b>			<b>Ok to Issue:</b> <input checked="" type="checkbox"/>
1) Application approval based upon information provided by applicant. Any deviation from approved plans requires separate review and approval prior to work.			

## BUILDING PERMIT INSPECTION PROCEDURES

Please call 874-8703 or 874-8693 (ONLY )

to schedule your inspections as agreed upon

Permits expire in 6 months, if the project is not started or ceases for 6 months.

The Owner or their designee is required to notify the inspections office for the following inspections and provide adequate notice. Notice must be called in 48-72 hours in advance in order to schedule an inspection:

**By initializing at each inspection time, you are agreeing that you understand the inspection procedure and additional fees from a "Stop Work Order" and "Stop Work Order Release" will be incurred if the procedure is not followed as stated below.**

**A Pre-construction Meeting will take place upon receipt of your building permit.**

  X   Footing/Building Location Inspection: Prior to pouring concrete or setting precast piers

  X   Final inspection required at completion of work.

Certificate of Occupancy is not required for certain projects. Your inspector can advise you if your project requires a Certificate of Occupancy. All projects DO require a final inspection.

**If any of the inspections do not occur, the project cannot go on to the next phase, REGARDLESS OF THE NOTICE OR CIRCUMSTANCES.**

**CERIFICATE OF OCCUPANICES MUST BE ISSUED AND PAID FOR, BEFORE THE SPACE MAY BE OCCUPIED.**

\_\_\_\_\_  
Signature of Applicant/Designee

*Thomas H. Maulley*  
\_\_\_\_\_  
Signature of Inspections Official

\_\_\_\_\_  
Date

*6/30/08*  
\_\_\_\_\_  
Date

# STAIR DETAILS FOR INSTITUTIONAL USES

### Typical institutional risers and treads

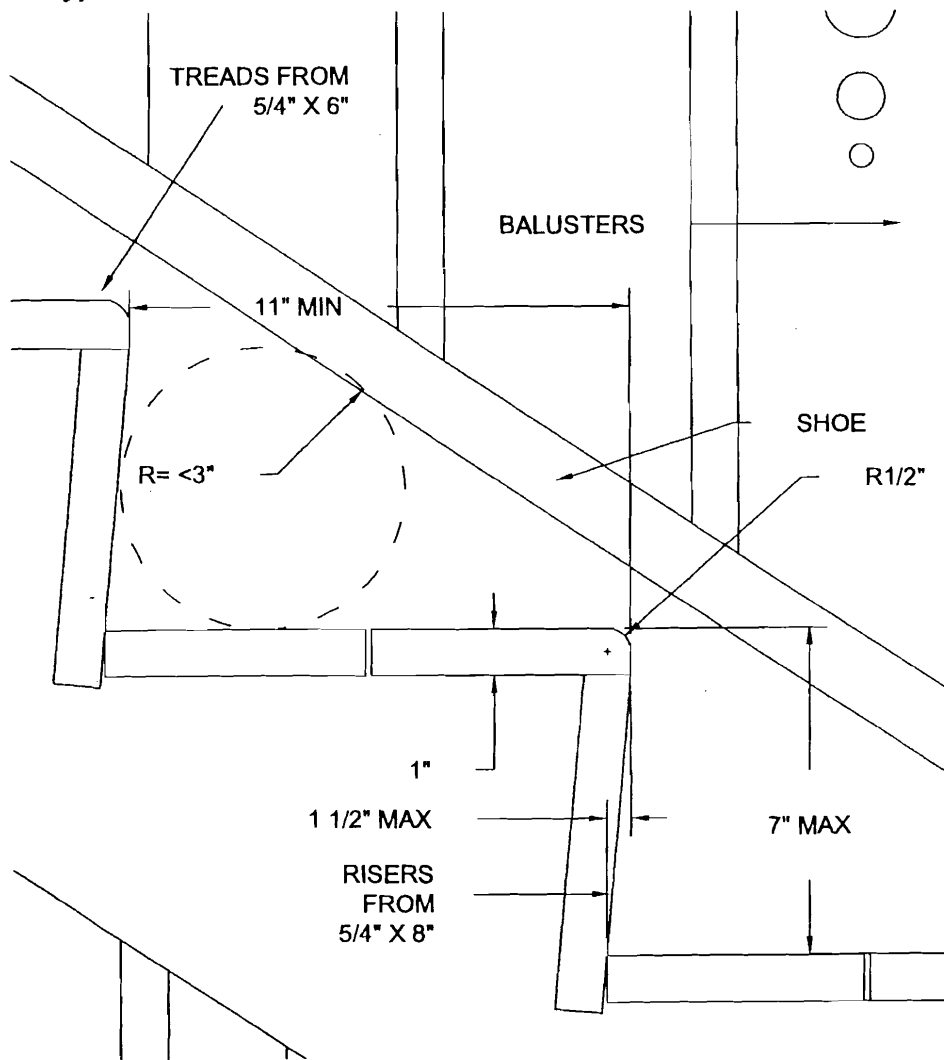

### Addition of handrail to existing stair

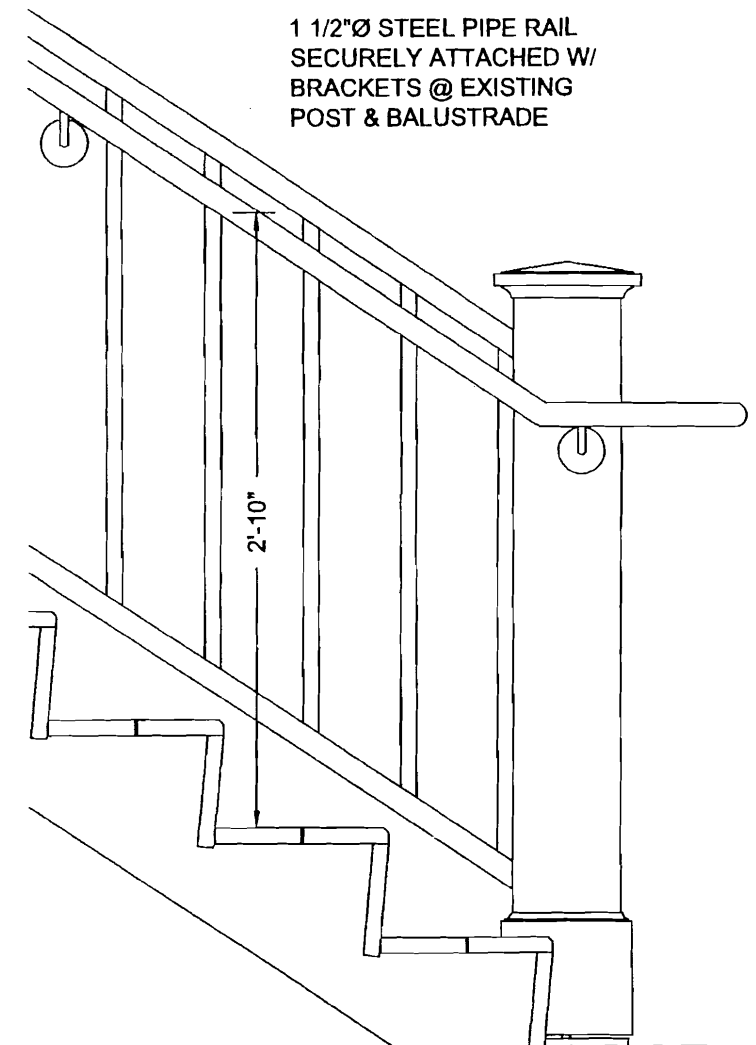

STAIR DETAILS FOR RESIDENTIAL USE

Typical residential risers and treads

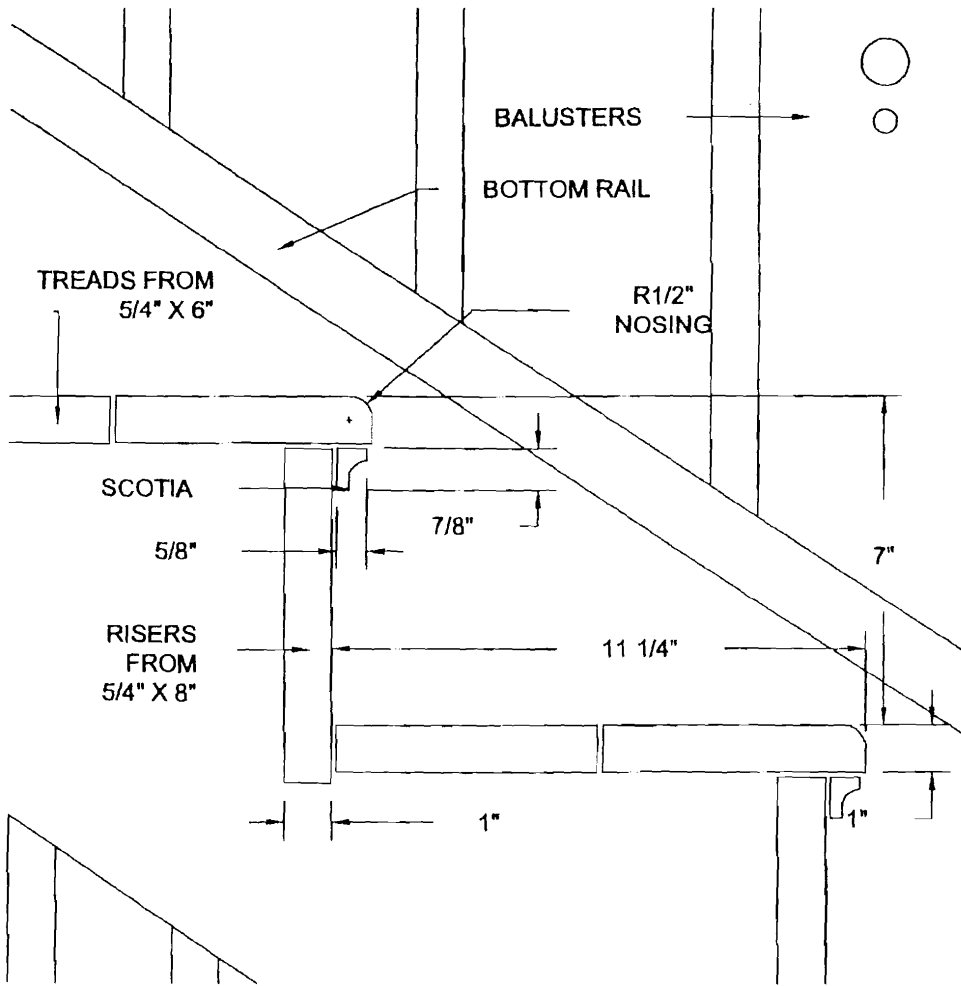

Typical newel post construction

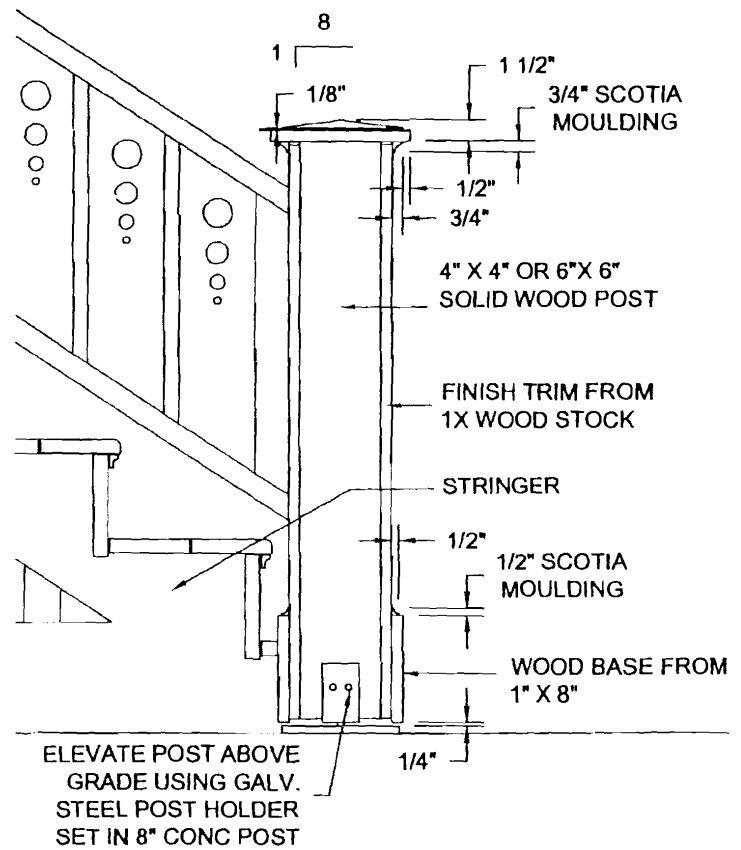

Alternate: Newel post may be bolted to a stringer.







# General Building Permit Application

If you or the property owner owes real estate or personal property taxes or user charges on any property within the City, payment arrangements must be made before permits of any kind are accepted.

Location/Address of Construction: <u>98 Clark St.</u>		
Total Square Footage of Proposed Structure/Area		Square Footage of Lot
Tax Assessor's Chart, Block & Lot Chart#      Block#      Lot# <u>57</u> <u>C</u> <u>33</u>	Applicant * <u>must</u> be owner, Lessee or Buyer* Name <u>Lydia F. Maier</u> Address <u>98 Clark St.</u> City, State & Zip <u>Portland ME 04102</u>	Telephone: <u>233-0584</u>
Lessee/DBA (If Applicable)	Owner (if different from Applicant) Name <u>same</u> Address City, State & Zip	Cost Of Work: \$ _____ C of O Fee: \$ _____ Total Fee: \$ <u>40</u>
Current legal use (i.e. single family) <u>2-unit as zoned</u> If vacant, what was the previous use? _____ Proposed Specific use: _____ Is property part of a subdivision? <u>No</u> If yes, please name _____ Project description: <u>Repair/Rear steps</u>		
Contractor's name: <u>Ben Pollard</u> Address: <u>30 Eastern Prom</u> City, State & Zip <u>Portland ME 04101</u> Telephone: <u>773-0764</u> Who should we contact when the permit is ready: <u>Lydia Maier</u> Telephone: <u>233-0584</u> Mailing address: <u>same</u>		

**Please submit all of the information outlined on the applicable Checklist. Failure to do so will result in the automatic denial of your permit.**

In order to be sure the City fully understands the full scope of the project, the Planning and Development Department may request additional information prior to the issuance of a permit. For further information or to download copies of this form and other applications visit the Inspections Division on-line at [www.portlandmaine.gov](http://www.portlandmaine.gov), or stop by the Inspections Division office, room 315 City Hall or call 874-8703.

I hereby certify that I am the Owner of record of the named property, or that the owner of record authorizes the proposed work and that I have been authorized by the owner to make this application as his/her authorized agent. I agree to conform to all applicable laws of this jurisdiction. In addition, if a permit for work described in this application is issued, I certify that the Code Official's authorized representative shall have the authority to enter all areas covered by this permit at any reasonable hour to enforce the provisions of the codes applicable to this permit.

Signature: Lydia F. Maier Date: June 27, 08

This is not a permit; you may not commence ANY work until the permit is issued.



**BUILDING PERMIT INSPECTION PROCEDURES**

Please call 874-8703 or 874-8693 (ONLY)

to schedule your inspections as agreed upon

Permits expire in 6 months, if the project is not started or ceases for 6 months.

The Owner or their designee is required to notify the inspections office for the following inspections and provide adequate notice. Notice must be called in 48-72 hours in advance in order to schedule an inspection:

**By initializing at each inspection time, you are agreeing that you understand the inspection procedure and additional fees from a "Stop Work Order" and "Stop Work Order Release" will be incurred if the procedure is not followed as stated below.**

**A Pre-construction Meeting will take place upon receipt of your building permit.**

  X   **Footing/Building Location Inspection: Prior to pouring concrete or setting precast piers**

  X   **Final inspection required at completion of work.**

Certificate of Occupancy is not required for certain projects. Your inspector can advise you if your project requires a Certificate of Occupancy. All projects DO require a final inspection.

**If any of the inspections do not occur, the project cannot go on to the next phase, REGARDLESS OF THE NOTICE OR CIRCUMSTANCES.**

**CERIFICATE OF OCCUPANICES MUST BE ISSUED AND PAID FOR, BEFORE THE SPACE MAY BE OCCUPIED.**

  Teresa J. Maurer    
Signature of Applicant/Designee

  6/30/08    
Date

  Mark H. McAuley    
Signature of Inspections Official

  6/30/08    
Date

2.	DICENTRA EXIMIA KING OF HEARTS	-
3.	ARUNCUS DIODICUS 'KNEIFFII'	6
4.	ASTILBE ARENDSII 'FANAL'	10
5.	HOSTA 'BIG DADDY'	4
6.	CARPINUS BETULUS 'FASTIGATA' EUROPEAN HORNBEAM	1
7.	OSMUNDA CINNAMOMEA 'CINNAMON FERN'	1
8.	CIMICIFUGA RACEMOSA	1
9.	RHODODENDRON 'ROSY MIRACLES'	1
10.	PACHYSANDRA TERMINALIS	10

HOUSE

