

2 BUILDING SECTION
1/2" = 1'-0"

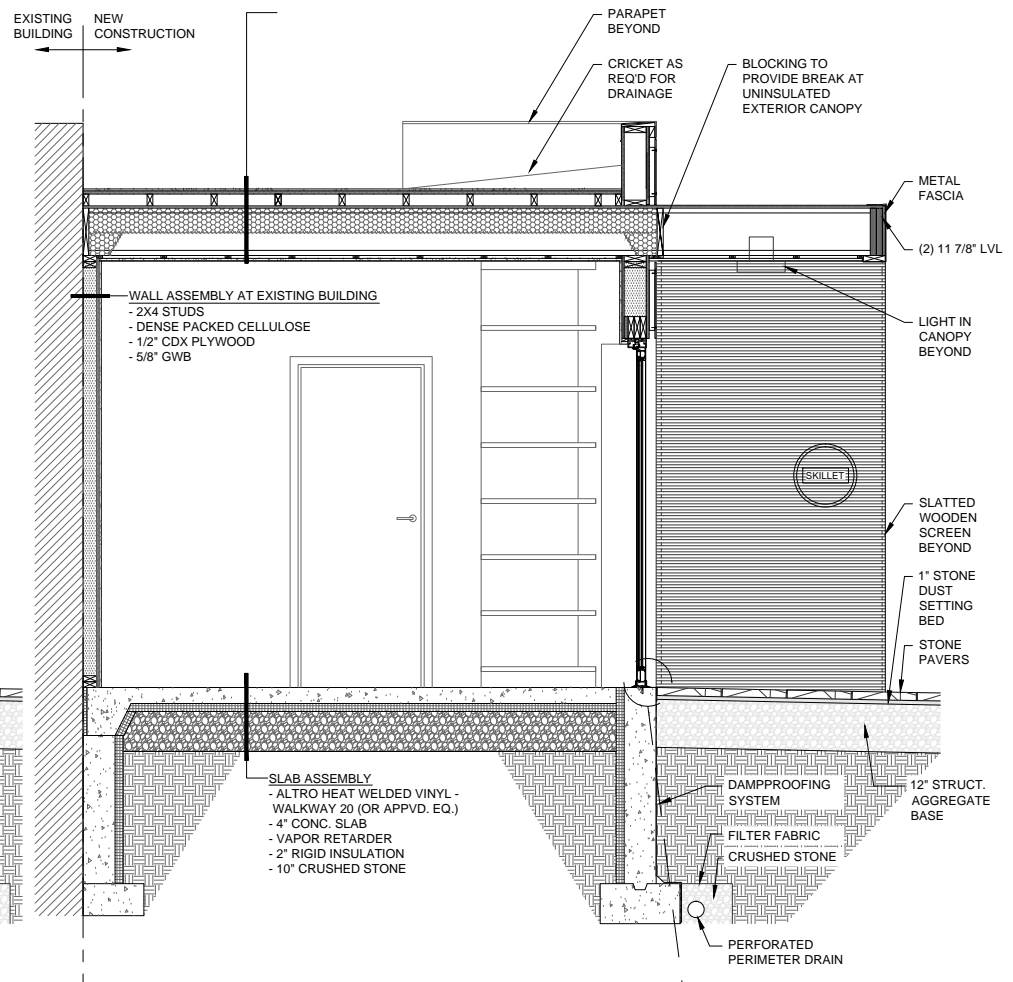

1 BUILDING SECTION
1/2" = 1'-0"

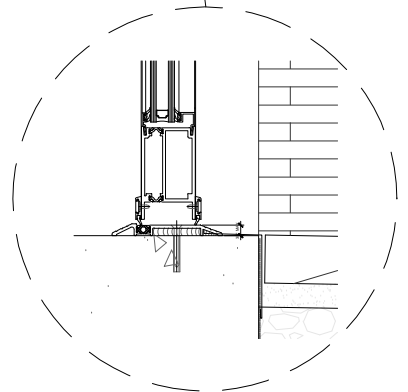

ferrer rogers DESIGN | leslie benson DESIGNS
19 Commercial Street Portland Maine 04101

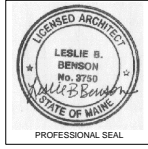

SKILLET TAKEOUT & CATERING
722 CONGRESS STREET
Portland Maine 04102

CONSULTANT

STATUS: PERMIT SET
NOT FOR CONSTRUCTION
ISSUE DATE: 7.11.14
ISSUE DATE: 7.28.14
ISSUE DATE: 7.31.14
ISSUE DATE: 8.27.14
ISSUE DATE: 9.17.14

PROJECT NO: 2014-100

A3.0
BUILDING SECTIONS