

City of Portland, Maine - Building or Use Permit Application

389 Congress Street, 04101 Tel: (207) 874-8703, Fax: (207) 874-8716

Permit No: 04-1317	Issue Date: <i>09/03/04</i>	CBL: 055 C002001
-----------------------	--------------------------------	---------------------

Location of Construction: 75 Carleton St	Owner Name: Bessa Paul & <i>203-550-6167</i>	Owner Address: 75 Carleton St	Phone:
Business Name:	Contractor Name: Owner	Contractor Address: Portland	Phone:
Lessee/Buyer's Name:	Phone:	Permit Type: Single Family	Zone: <i>R6</i>

Past Use: Single Family Home	Proposed Use: Single Family Home / Build 5'6" x Deck <i>14'-3"</i>	Permit Fee:	Cost of Work: \$0.00	CEO District: 2
---------------------------------	---	-------------	-------------------------	--------------------

Proposed Project Description: Build 5'6" x Deck <i>14'-3"</i>	FIRE DEPT: <i>N/A</i> <input type="checkbox"/> Approved <input checked="" type="checkbox"/> Denied Signature:	INSPECTION: Use Group: <i>R-3</i> Type: <i>5B</i> <i>BOCA 1999</i> Signature:
---	---	--

PEDESTRIAN ACTIVITIES DISTRICT (P.A.D.)		
Action: <input type="checkbox"/> Approved	<input type="checkbox"/> Approved w/Conditions	<input checked="" type="checkbox"/> Denied
Signature:	Date:	

Permit Taken By: Idobson	Date Applied For: 09/03/2004	Zoning Approval	
-----------------------------	---------------------------------	------------------------	--

<ol style="list-style-type: none"> This permit application does not preclude the Applicant(s) from meeting applicable State and Federal Rules. Building permits do not include plumbing, septic or electrical work. Building permits are void if work is not started within six (6) months of the date of issuance. False information may invalidate a building permit and stop all work.. 	Special Zone or Reviews <input type="checkbox"/> Shoreland <input type="checkbox"/> Wetland <input type="checkbox"/> Flood Zone <input type="checkbox"/> Subdivision <input type="checkbox"/> Site Plan Maj <input type="checkbox"/> Minor <input type="checkbox"/> MM <input type="checkbox"/> Date: <i>9/14/04</i>	Zoning Appeal <input type="checkbox"/> Variance <input type="checkbox"/> Miscellaneous <input type="checkbox"/> Conditional Use <input type="checkbox"/> Interpretation <input type="checkbox"/> Approved <input type="checkbox"/> Denied Date:	Historic Preservation <input type="checkbox"/> Not in District or Landmark <input type="checkbox"/> Does Not Require Review <input type="checkbox"/> Requires Review <input type="checkbox"/> Approved <input checked="" type="checkbox"/> Approved w/Conditions <i>see form</i> <input type="checkbox"/> Denied Date: <i>9/16/04</i> <i>Dr. Andrews</i>
---	--	---	--

CERTIFICATION

I hereby certify that I am the owner of record of the named property, or that the proposed work is authorized by the owner of record and that I have been authorized by the owner to make this application as his authorized agent and I agree to conform to all applicable laws of this jurisdiction. In addition, if a permit for work described in the application is issued, I certify that the code official's authorized representative shall have the authority to enter all areas covered by such permit at any reasonable hour to enforce the provision of the code(s) applicable to such permit.

SIGNATURE OF APPLICANT	ADDRESS	DATE	PHONE
------------------------	---------	------	-------

RESPONSIBLE PERSON IN CHARGE OF WORK, TITLE	DATE	PHONE
---	------	-------

DISPLAY THIS CARD ON PRINCIPAL FRONTAGE OF WORK
CITY OF PORTLAND

Please Read
 Application And
 Notes, if Any,
 Attached

DEPARTMENT OF BUILDING INSPECTION
PERMIT

Permit Number: 041317

This is to certify that Bessa Paul & /Owner

has permission to Build 5'6" x 14'-3" Deck

AT 75 Carleton St

055 C002001

provided that the person or persons, firm or corporation accepting this permit shall comply with all of the provisions of the Statutes of the State and of the Ordinances of the City of Portland regulating the construction, maintenance and use of buildings and structures, and of the application on file in this department.

Apply to Public Works for street line and grade if nature of work requires such information.

Notification of inspection must be given and when permission is procured before this building or part thereof is occupied or closed-in.
 24 HOUR NOTICE IS REQUIRED.

A certificate of occupancy must be procured by owner before this building or part thereof is occupied.

OTHER REQUIRED APPROVALS

Fire Dept. _____

Health Dept. _____

Appeal Board _____

Other _____

Department Name

Director - Building & Inspection Services

PENALTY FOR REMOVING THIS CARD

9/14/04

SEP 20 2004

COPY OF PERMIT AND

City of Portland, Maine - Building or Use Permit

389 Congress Street, 04101 Tel: (207) 874-8703, Fax: (207) 874-8716

Permit No: 04-1317	Date Applied For: 09/03/2004	CBL: 055 C002001
-----------------------	---------------------------------	---------------------

Location of Construction: 75 Carleton St	Owner Name: Bessa Paul &	Owner Address: 75 Carleton St	Phone:
Business Name:	Contractor Name: Owner	Contractor Address: Portland	Phone
Lessee/Buyer's Name	Phone:	Permit Type: Single Family	

Proposed Use: Single Family Home / Build 5'6" x 14' Deck	Proposed Project Description: Build 5'6" x 14' Deck
---	--

Dept: Historical **Status:** Approved with Conditions **Reviewer:** **Approval Date:** 09/10/2004

Note: **Ok to Issue:**

- 1) * The leading edge of the deck is to be set back at least 6 inches from the side wall of the main house.
 * Railing to be red cedar; no pressure treated lumber for finished surfaces. Railing to be painted or opaque stained to match body of house.
 * Railing balusters to be square, 2"x2", spaced 4" on center.
 * The rail itself is to be continuous; the posts shall not project above the rail.
 * All posts to be 4" square red cedar posts
 * The proposed roof element to be eliminated from the plans; if a retractable awning is desired, specification to be submitted to staff

Dept: Zoning **Status:** Approved with Conditions **Reviewer:** Tammy Munson **Approval Date:** 09/17/2004

Note: 9/14/04 given to Tammy who approved the original permit - this is a single family **Ok to Issue:**

- 1) An inspection must occur prior to commencement of construction in order to verify dimensions of all existing structures due to lot coverage.

Dept: Building **Status:** Approved **Reviewer:** Tammy Munson **Approval Date:** 09/17/2004

Note: **Ok to Issue:**

Comments:

9/3/04-ldobson: No fee for this permit. Paid full amount on original permit #040958

CITY OF PORTLAND, MAINE

HISTORIC PRESERVATION COMMITTEE

Cordelia Pitman, Chair
John Turk, Vice Chair
Camillo Breggia
Edward Hobler
Robert Parker
Steve Sewall
Susan Wroth

September 9, 2004

Paul Bessa
75 Carleton Street
Portland, ME 04102

Re: 75 Carleton Street – Deck Construction

Dear Mr. Bessa:

On September 1, 2004, the City of Portland's Historic Preservation Committee voted 6-0 (Wroth absent) to approve your application for a Certificate of Appropriateness for the construction of a second-story deck at 75 Carleton Street.

Committee approval was made subject to the following conditions:

- The leading edge of the deck is to be set back at least 6" from the side wall of the main house.
- Railing to be red cedar – no pressure treated lumber for finished surfaces. Railing to be painted or opaque stained to match body of house.
- Railing balusters to be square, 2"x2", spaced 4" on center.
- The rail itself is to be continuous; the posts shall not project above the rail.
- All posts to be 4" square red cedar posts
- The proposed roof element to be eliminated from the plans; if a retractable awning is desired, specification to be submitted to staff

All improvements shall be carried out as shown on the submitted plans and specifications submitted for the 9/1/04 public hearing, except as to comply with the conditions above. Changes to the approved plans and specifications and any additional work that may be undertaken must be reviewed and approved by this office prior to construction, alteration, or demolition. If, during the course of completing the approved work, conditions are encountered which prevent completing the approved work, or which require additional or alternative work, you must apply for and receive a Certificate of Appropriateness or Non-Applicability PRIOR to undertaking additional or alternative work.

This Certificate is granted upon condition that the work authorized herein is commenced within twelve (12) months after the date of issuance. If the work authorized by this Certificate is not commenced within twelve (12) months after the date of issuance or if such work is suspended in significant part for a period of

one year after the time the work is commenced, such Certificate shall expire and be of no further effect; provided that, for cause, one or more extensions of time for periods not exceeding ninety (90) days each may be allowed in writing by the Department.

Sincerely,

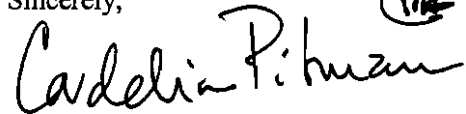

Cordelia Pitman, Chair
Historic Preservation Committee

cc: Approval Letter File
Building Inspections

04137

All Purpose Building Permit Application

If you or the property owner owes real estate or personal property taxes or user charges on any property with the City, payment arrangements must be made before permits of any kind are accepted.

Location/Address of Construction: <u>75 Carleton</u>		
Total Square Footage of Proposed Structure	Square Footage of Lot	
Tax Assessor's Chart, Block & Lot Chart# <u>55</u> Block# <u>C</u> Lot# <u>2</u>	Owner: <u>Paul Bessy</u>	Telephone: <u>775-0419</u>
Lessee/Buyer's Name (if Applicable)	Applicant name, address & telephone: <u>Paul Bessy</u> <u>75 Carleton Street</u> <u>Portland ME 04102</u>	Cost Of Work: \$ Fee: \$ <u>NA</u>
Current use: <u>Garden</u>		<u>Previous Permit</u>
If the location is currently vacant, what was prior use: _____		
Approximately how long has it been vacant: _____		
Proposed use: <u>Deck</u>		<u>SEP-3-04</u>
Project description: <u>5'-6" x 16'</u>		
Contractor's name, address & telephone: _____		
Who should we contact when the permit is ready: _____		
Mailing address: _____		
We will contact you by phone when the permit is ready. You must come in and pick up the permit and review the requirements before starting any work, with a Plan Reviewer. A stop work order will be issued and a \$100.00 fee if any work starts before the permit is picked up. PHONE: _____		

IF THE REQUIRED INFORMATION IS NOT INCLUDED IN THE SUBMISSIONS THE PERMIT WILL BE AUTOMATICALLY DENIED AT THE DISCRETION OF THE BUILDING/PLANNING DEPARTMENT, WE MAY REQUIRE ADDITIONAL INFORMATION IN ORDER TO APPROVE THIS PERMIT.

I hereby certify that I am the Owner of record of the named property, or that the owner of record authorizes the proposed work and that I have been authorized by the owner to make this application as his/her authorized agent. I agree to conform to all applicable laws of this jurisdiction. In addition, if a permit for work described in this application is issued, I certify that the Code Official's authorized representative shall have the authority to enter all areas covered by this permit at any reasonable hour to enforce the provisions of the codes applicable to this permit.

Signature of applicant: <u>Paul Bessy</u>	Date: <u>Sept 3 / 04</u>
---	--------------------------

This is NOT a permit, you may not commence ANY work until the permit is issued. If you are in a Historic District you may be subject to additional permitting and fees with the Planning Department on the 4th floor of City Hall

ELECTRICAL PERMIT

City of Portland, Me.



9/17 2:00

To the Chief Electrical Inspector, Portland Maine:
 The undersigned hereby applies for a permit to make electrical installations
 in accordance with the laws of Maine, the City of Portland Electrical Ordinance,
 National Electrical Code and the following specifications:

Date 9.13.04
 Permit # 2004-4994
 CBL# SSC2

LOCATION: 75 Carlton St METER MAKE & # _____
 CMP ACCOUNT # _____ OWNER Paul Bessa
 TENANT _____ PHONE # 75 0419

						TOTAL	EACH FEE	
OUTLETS	20	Receptacles	12	Switches	4	Smoke Detector	.20	2.20
FIXTURES	12	Incandescent		Fluorescent		Strips	.20	2.40
SERVICES		Overhead		Underground		TTL AMPS <800	15.00	
		Overhead		Underground		>800	25.00	
Temporary Service		Overhead		Underground		TTL AMPS	25.00	
							25.00	
METERS		(number of)					1.00	
MOTORS		(number of)					2.00	
RESID/COM		Electric units					1.00	
HEATING		oil/gas units		Interior		Exterior	5.00	
APPLIANCES	1	Ranges		Cook Tops		Wall Ovens	2.00	2.00
		Insta-Hot		Water heaters		Fans	2.00	
		Dryers	1	Disposals	1	Dishwasher	2.00	8.00
		Compactors		Spa		Washing Machine	2.00	
		Others (denote)					2.00	
MISC. (number of)		Air Cond/win					3.00	
		Air Cond/cent				Pools	10.00	
		HVAC		EMS		Thermostat	5.00	
		Signs					10.00	
		Alarms/res					5.00	
		Alarms/com					15.00	
		Heavy Duty(CRKT)					2.00	
	Circus/Carnv					25.00		
	Alterations					5.00		
	Fire Repairs					15.00		
	E Lights					1.00		
	E Generators					20.00		
PANELS		Service	1	Remote		Main	4.00	4.00
TRANSFORMER		0-25 Kva					5.00	
		25-200 Kva					8.00	
		Over 200 Kva					10.00	
						TOTAL AMOUNT DUE		
						MINIMUM FEE/COMMERCIAL 45.00	MINIMUM FEE	35.00

CONTRACTORS NAME T. A. NAPOLITANO MASTER LIC. # 7765
 ADDRESS P.O. Box 2301 S.P. LIMITED LIC. # _____
 TELEPHONE 799-0538
 SIGNATURE OF CONTRACTOR T. A. Napolitano

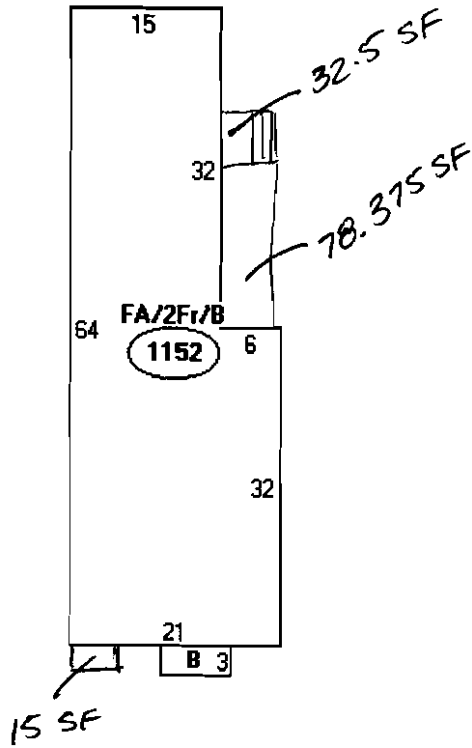

Descriptor/Area

A: FA/2Fr/B
1152 sqft

B: 2FBAY/B
21 sqft

32.5
78.375
15

1298.875

2600
x 50%

1300 Allowed

City of Portland, Maine - Building or Use Permit Application

389 Congress Street, 04101 Tel: (207) 874-8703, Fax: (207) 874-8716

Permit No: 04-0958	Issue Date: AUG 11 2004	CBL: 055 C002001
-----------------------	----------------------------	---------------------

Location of Construction: 75 Carleton St	Owner Name: Bessa Paul &	Owner Address: 75 Carleton St	Phone: 75-0419
Business Name:	Contractor Name: Owner	Contractor Address: Portland	Phone: 0000000000
Lessee/Buyer's Name:	Phone:	Permit Type: Alterations - Dwellings	Zone: R-6

Past Use: single family residence	Proposed Use: renovations to single family residence	Permit Fee: \$201.00	Cost of Work: \$20,000.00	CEO District: 2
--------------------------------------	---	-------------------------	------------------------------	--------------------

FIRE DEPT: <input type="checkbox"/> Approved <input checked="" type="checkbox"/> Denied <i>N/A</i>	INSPECTION: Use Group: <i>R-3</i> Type: <i>SB</i> <i>BOCA 1999</i>
Signature:	Signature:

Proposed Project Description:
renovations to single family residence

PEDESTRIAN ACTIVITIES DISTRICT (P.A.D.)

Action: Approved Approved w/Conditions Denied

Signature: _____ Date: _____

Permit Taken By: jodinea	Date Applied For: 07/13/2004	Zoning Approval	
-----------------------------	---------------------------------	------------------------	--

- This permit application does not preclude the Applicant(s) from meeting applicable State and Federal Rules.
- Building permits do not include plumbing, septic or electrical work.
- Building permits are void if work is not started within six (6) months of the date of issuance. False information may invalidate a building permit and stop all work..

Special Zone or Reviews

Shoreland

Wetland

Flood Zone

Subdivision

Site Plan

Maj Minor MM

Date: *8/11/04*

Zoning Appeal

Variance

Miscellaneous

Conditional Use

Interpretation

Approved

Denied

Date: _____

Historic Preservation

Not in District or Landmark

Does Not Require Review

Requires Review

Approved

Approved w/Conditions

Denied

Partial Approval

Date: *D. Andrews 8/4/04*

CERTIFICATION

I hereby certify that I am the owner of record of the named property, or that the proposed work is authorized by the owner of record and that I have been authorized by the owner to make this application as his authorized agent and I agree to conform to all applicable laws of this jurisdiction. In addition, if a permit for work described in the application is issued, I certify that the code official's authorized representative shall have the authority to enter all areas covered by such permit at any reasonable hour to enforce the provision of the code(s) applicable to such permit.

SIGNATURE OF APPLICANT _____ ADDRESS _____ DATE _____ PHONE _____

RESPONSIBLE PERSON IN CHARGE OF WORK, TITLE _____ DATE _____ PHONE _____

All Purpose Building Permit Application

If you or the property owner owes real estate or personal property taxes or user charges on any property within the City, payment arrangements must be made before permits of any kind are accepted.

Location/Address of Construction: <u>75 CARLETON ST. PORTLAND, ME 04102</u>		
Total Square Footage of Proposed Structure	Square Footage of Lot	
Tax Assessor's Chart, Block & Lot Chart# Block# Lot# <u>55 C 2</u>	Owner: <u>PAUL & RENATA BESSA</u>	Telephone: <u>775-0419</u>
Lessee/Buyer's Name (If Applicable)	Applicant name, address & telephone: <u>PAUL BESSA 75 CARLETON ST. PORTLAND, ME 775-0419</u>	Cost Of Work: \$ <u>20,000</u> Fee: \$
Current use: <u>RESIDENCE</u>		
If the location is currently vacant, what was prior use: _____		
Approximately how long has it been vacant: _____		
Proposed use: _____		
Project description: _____		
Contractor's name, address & telephone: _____		
Who should we contact when the permit is ready: <u>PAUL BESSA</u>		
Mailing address: <u>75 CARLETON ST. PORTLAND, ME 04102</u>		
We will contact you by phone when the permit is ready. You must come in and pick up the permit and review the requirements before starting any work, with a Plan Reviewer. A stop work order will be issued and a \$100.00 fee if any work starts before the permit is picked up. PHONE: <u>775-0419 3497</u>		



IF THE REQUIRED INFORMATION IS NOT INCLUDED IN THE SUBMISSIONS THE PERMIT WILL BE AUTOMATICALLY DENIED AT THE DISCRETION OF THE BUILDING/PLANNING DEPARTMENT, WE MAY REQUIRE ADDITIONAL INFORMATION IN ORDER TO APPROVE THIS PERMIT.

I hereby certify that I am the Owner of record of the named property, or that the owner of record authorizes the proposed work and that I have been authorized by the owner to make this application as his/her authorized agent. I agree to conform to all applicable laws of this jurisdiction. In addition, if a permit for work described in this application is issued, I certify that the Code Official's authorized representative shall have the authority to enter all areas covered by this permit at any reasonable hour to enforce the provisions of the codes applicable to this permit.

Signature of applicant: <u><i>Paul Bessa</i></u>	Date: <u>7/12/04</u>
--	----------------------

This is NOT a permit, you may not commence ANY work until the permit is issued. If you are in a Historic District you may be subject to additional permitting and fees with the Planning Department on the 4th floor of City Hall

BUILDING PERMIT INSPECTION PROCEDURES

Please call 874-8703 or 874-8693 to schedule your inspections as agreed upon

Permits expire in 6 months, if the project is not started or ceases for 6 months.

The Owner or their designee is required to notify the inspections office for the following inspections and provide adequate notice. Notice must be called in 48-72 hours in advance in order to schedule an inspection:

By initializing at each inspection time, you are agreeing that you understand the inspection procedure and additional fees from a "Stop Work Order" and "Stop Work Order Release" will be incurred if the procedure is not followed as stated below.

A Pre-construction Meeting will take place upon receipt of your building permit.

- Call Footing/Building Location Inspection: Prior to pouring concrete
- NA Re-Bar Schedule Inspection: Prior to pouring concrete
- Call Foundation Inspection: Prior to placing ANY backfill
- Call Framing/Rough Plumbing/Electrical: Prior to any insulating or drywalling
- Call Final/Certificate of Occupancy: Prior to any occupancy of the structure or use. NOTE: There is a \$75.00 fee per inspection at this point.

Certificate of Occupancy is not required for certain projects. Your inspector can advise you if your project requires a Certificate of Occupancy. All projects DO require a final inspection

 If any of the inspections do not occur, the project cannot go on to the next phase, REGARDLESS OF THE NOTICE OR CIRCUMSTANCES.

CERIFICATE OF OCCUPANICES MUST BE ISSUED AND PAID FOR, BEFORE THE SPACE MAY BE OCCUPIED

Paul D.essa
Signature of Applicant/Designee

Paul D.essa
Signature of Inspections Official

Date 9/23/04
Date

CBL: 055 002 Building Permit #: 04 1317