

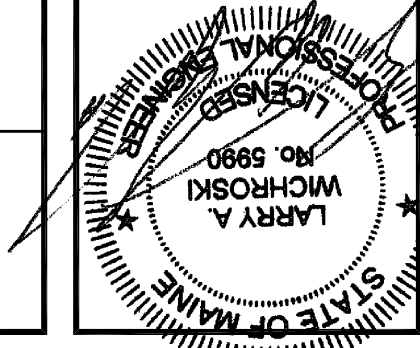

Baker Residence Remodel  
14 Blyth Circle \* Portland \* Maine  
DETAILS & STRUCTURAL NOTES



DESIGNED BY:  
Larry Wchroski, P.E.  
DRAWN BY:  
LAW  
JOB NO. 01813  
DATE: 06-20-2013

REVISIONS  
10-03-2013

SHEET: S1 of 2

**STRUCTURAL NOTES:**  
CODE: Comply with the 2009 International Residential Code.

**DESIGN LOADS:**

Roof = 16.0 psf. Floor = 12.0 psf.  
Live Loads: Roof = 45.0 psf (Plus Drift), 1st Floor = 40.0 psf, 2nd Floor = 30.0 psf.  
Wind Load: Building = 31.0 psf

**FOUNDATIONS:**

- Bear footings on firm, undisturbed dense native soil at 4'-6" minimum below lowest adjacent finish or natural grade, whichever is lower.
- Assumed soil bearing pressure = 1,500 psf.
- Place foundation concrete only on clean, firm, dry bearing material.
- Engineer shall be notified if stone ledge or marine clay is found during excavation.

**CONCRETE:**

- Concrete require weight (144 pcf) with Type II cement per ASTM C150, aggregate per ASTM C33, and potable water. No fly-ash permitted in floor slab. Aggregate size = 1" maximum for footings and slab. Minimum compressive strength = 3000 psi for foundations and slab on grade and 4,000 psi for exterior slabs and sidewalks.
- Saw cuts for floor slab control joints shall be made as soon as the slab can support the weight of the saw, but no more than 12 hours after placing concrete.

**REINFORCING:**

- ASTM A 615-S1, Grade 60 except #2 and #3 bars ASTM A615-S1: Grade 40.
- Steel Lally Columns: ASTM A513, Fy = 32 ksi. 16 gage steel filled w/ 3,000 psi concrete.
- Provide bent corner reinforcing to match and lap with horizontal reinforcing at corners and intersections of walls, and footings.

**STEEL:**

- Roll sections and plates: ASTM A-36, Fy = 36 ksi.
- Steel Lally Columns: ASTM A513, Fy = 32 ksi. 16 gage steel filled w/ 3,000 psi concrete.
- Bolts and plain anchors: ASTM A 307.

**WOOD:**

- Each piece of lumber shall be "S-DRY" and bear the grade stamp of a grading rules agency approved by the American Lumber Standards Committee.
- Double up studs at joints and under beams.
- Do not notch or drill joists, beams or load bearing studs without approval.

**Connections:**

- Nail roof plywood with 8d common at 6" o.c. at all edges and boundary members and 10" o.c. at intermediate supports.
- Glue floor plywood to all framing members and nail with 8d common at 6" o.c. at all plywood edges and boundary members and 10" o.c. at intermediate supports.
- Nail all plywood with 10d common nails at 6" o.c. at all edges and boundary members and 12" o.c. at intermediate supports.
- Species:
  - 2 x 4 dim 2 x 14 joists: Spruce Pine Fir No. 2 with Fb (repetitive) = 1200 psi.
  - Studs: Spruce Pine Fir No. 2 with Fb (repetitive) = 1200 psi.
  - Laminated Veneer Lumber (LVL): Fb = 2800 psi; Fv = 285 psi; E = 2,000 ksi
  - Parallam Veneer Lumber (PL): Fb = 2900 psi; Fv = 290 psi; E = 2,000 ksi

- Plywood:
  - Roof Sheathing: C-D INT-APA (PSI-94) with exterior glue, 1/2" with Identification Index 4824. Lay up with face grain perpendicular to supports. Stagger joints. Each plywood piece to be continuous over a minimum of two spans with a minimum width of 1'-0" unless blocking is provided at all joints.
  - Sub-flooring: C-D INT-APA (PSI-94) with exterior glue, 3/4" with Identification Index 4824. Lay up with face grain perpendicular to supports. Stagger joints. Each plywood piece to be continuous over a minimum of two spans with a minimum width of 1'-0" unless blocking is provided at all joints.
  - Wall Sheathing: C-D INT-APA (PSI-74) with exterior glue, 1/2" with Identification Index 2400. All panel edges backed with 2" nominal or wider framing.

**SUPPLEMENTARY NOTES:**

- Verify all dimensions and conditions with architectural drawings prior to starting work. Notify the Engineer of any discrepancies or inconsistencies.
- Provide all necessary temporary bracing, shoring, guying or other means to avoid excessive stresses and to hold structural elements in place during construction.

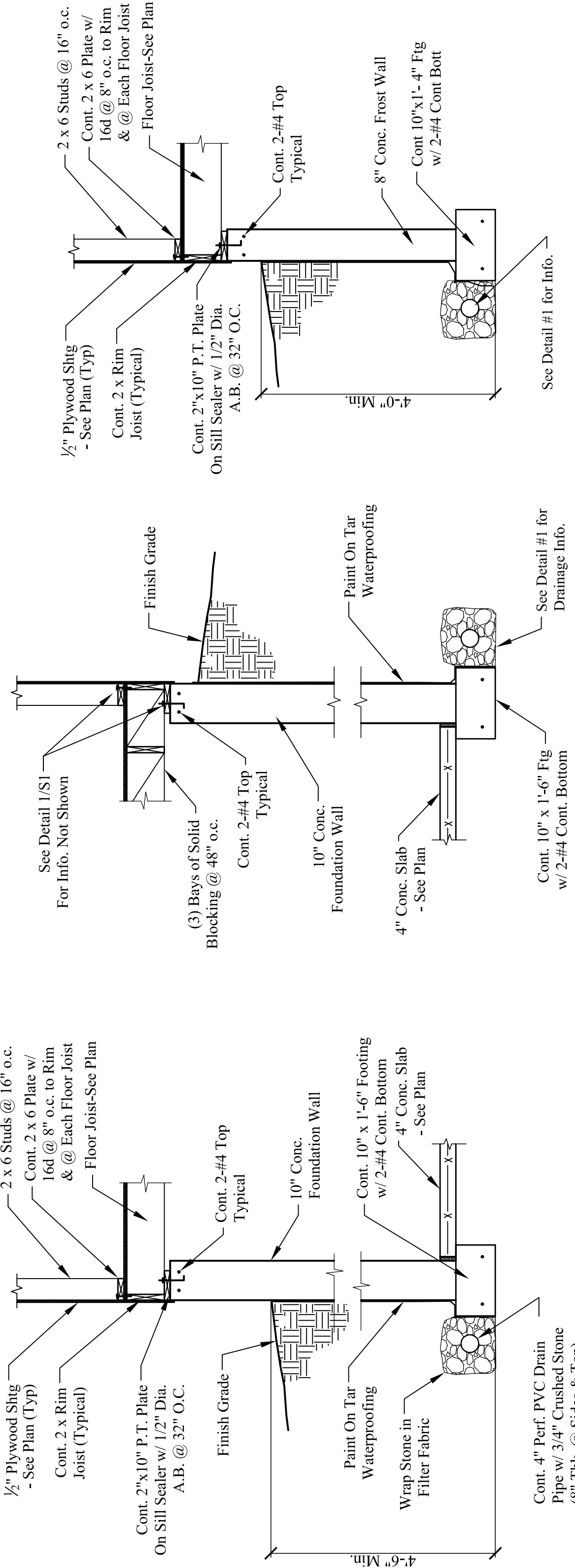

**2 BSMT FND WALL**  
Scale: 1/2" = 1'-0"



**3 FOUNDATION FROST WALL**  
Scale: 1/2" = 1'-0"



**4 INTERIOR COL. FOOTING**  
Scale: 1/2" = 1'-0"

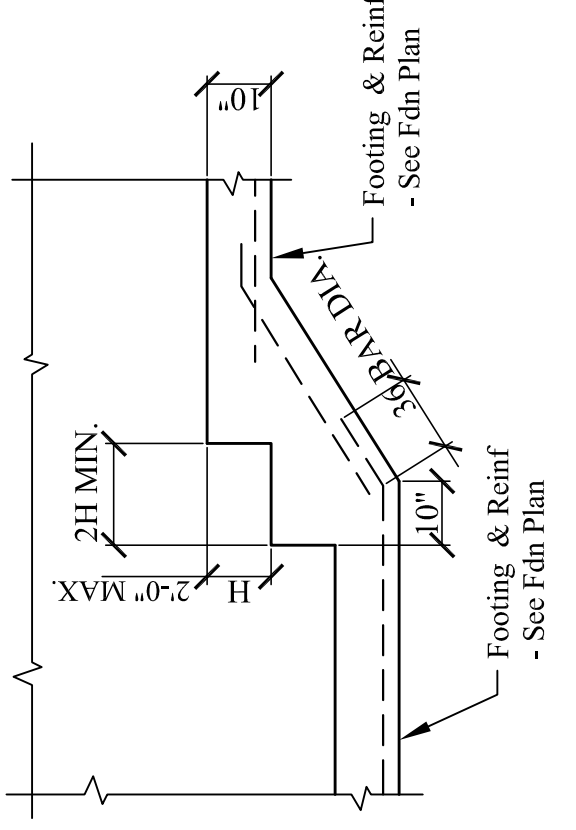

**6 TYP STEP FOOTING DETAIL**  
Scale: 1/2" = 1'-0"

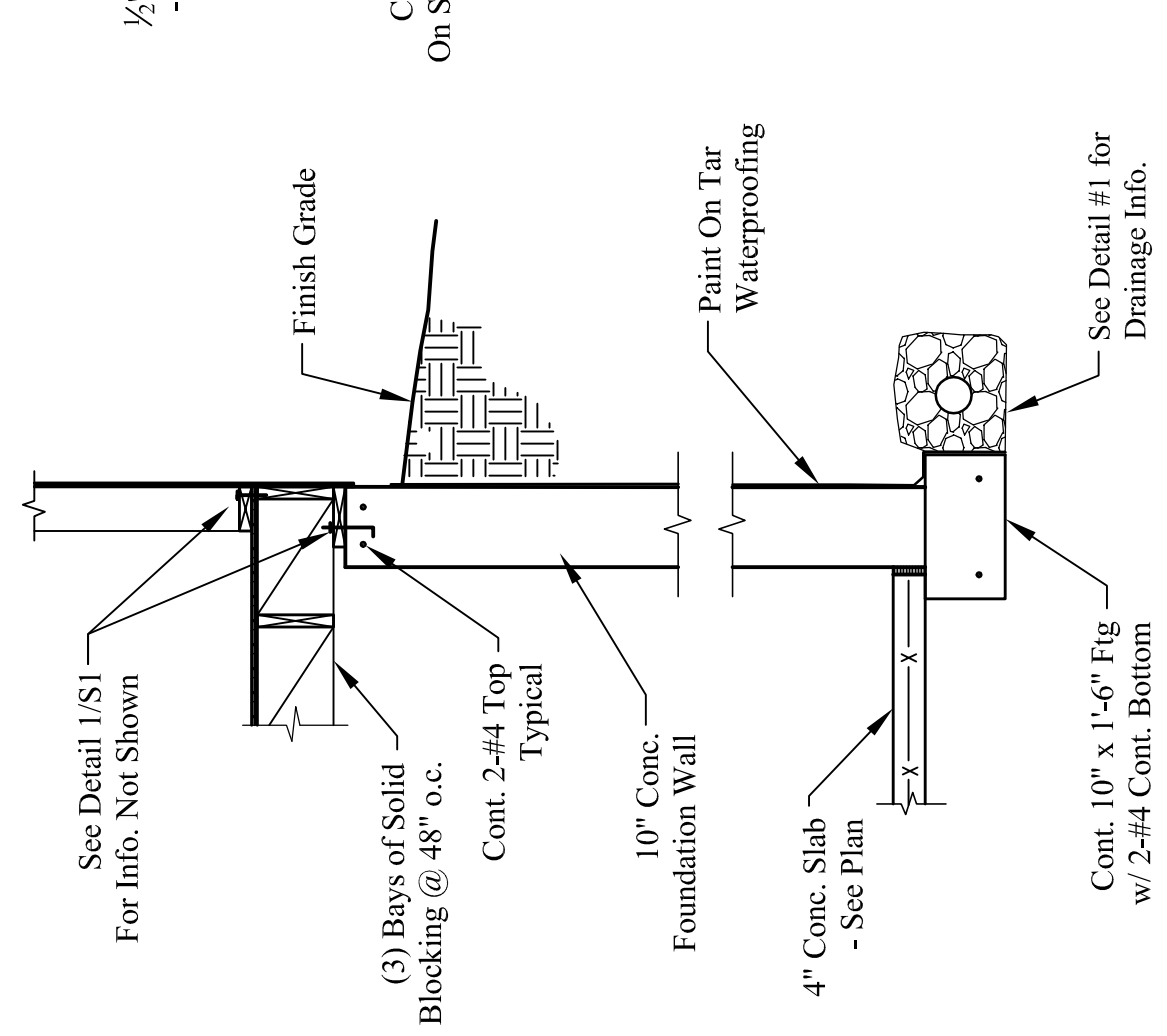
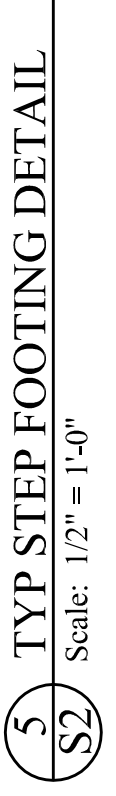

**7 BSMT FND WALL**  
Scale: 1/2" = 1'-0"

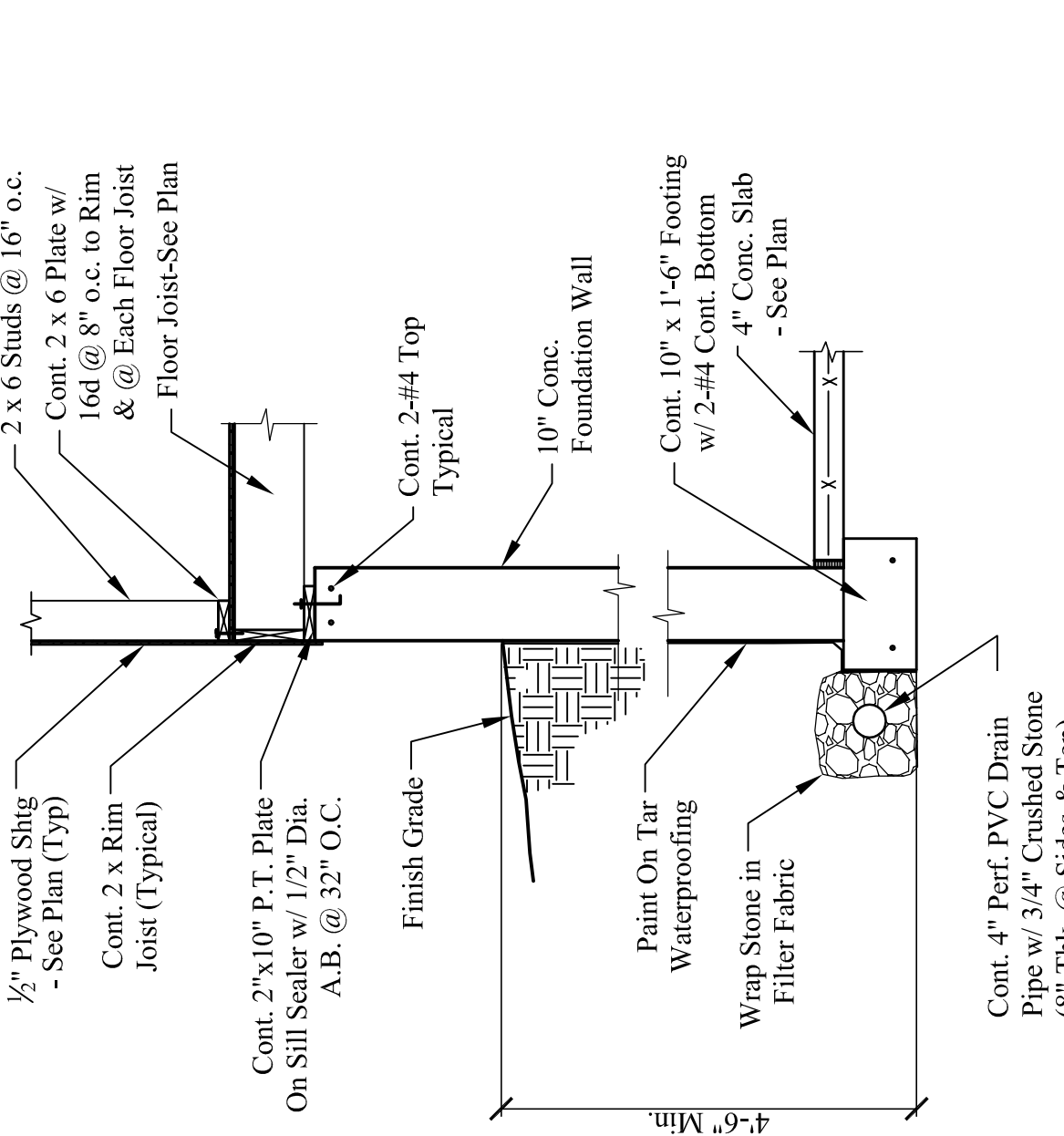

**8 BSMT FND WALL**  
Scale: 1/2" = 1'-0"

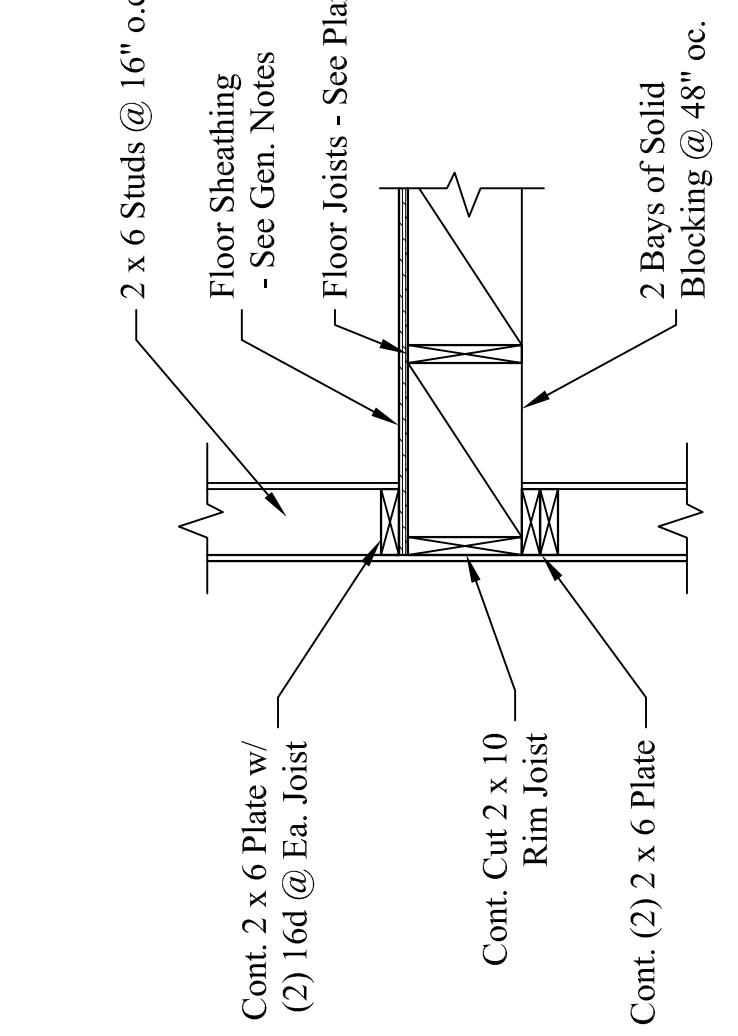

**14 JOIST PARRALEL w/ EXT. WALL**  
SCALE: 3/4" = 1'-0"

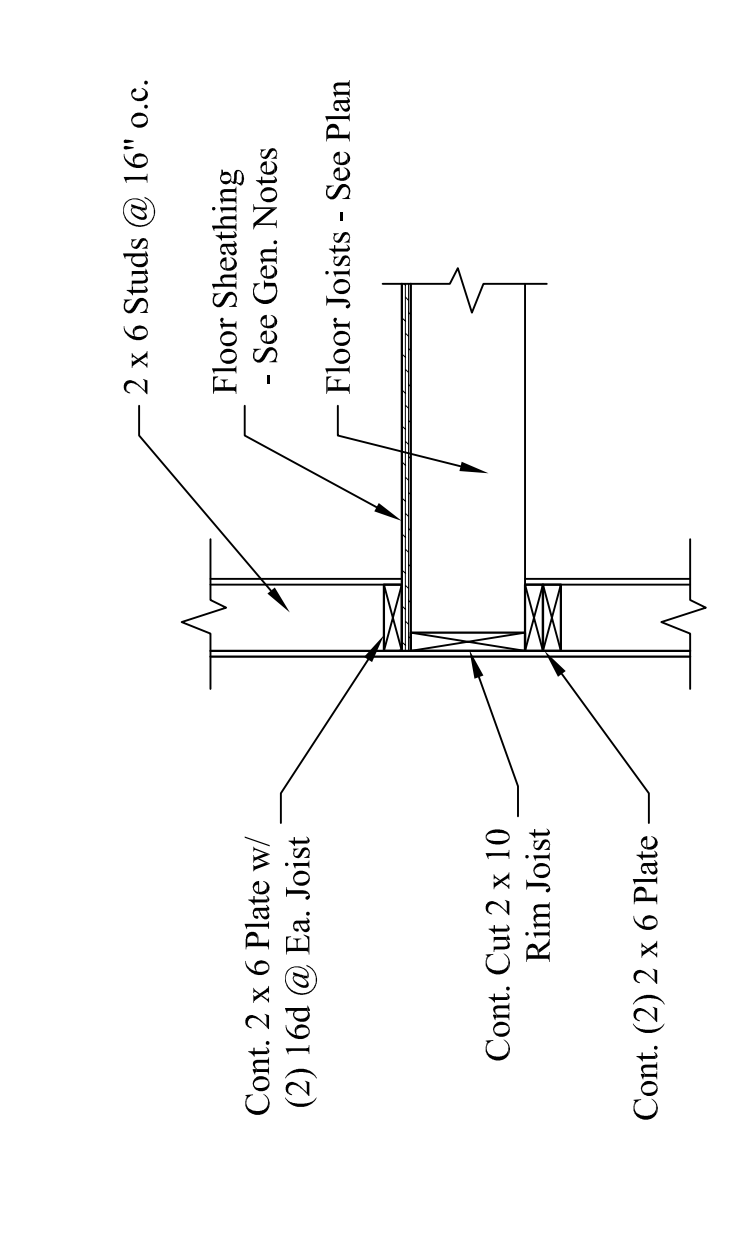

**13 JOIST @ EXT. BRG WALL**  
SCALE: 3/4" = 1'-0"

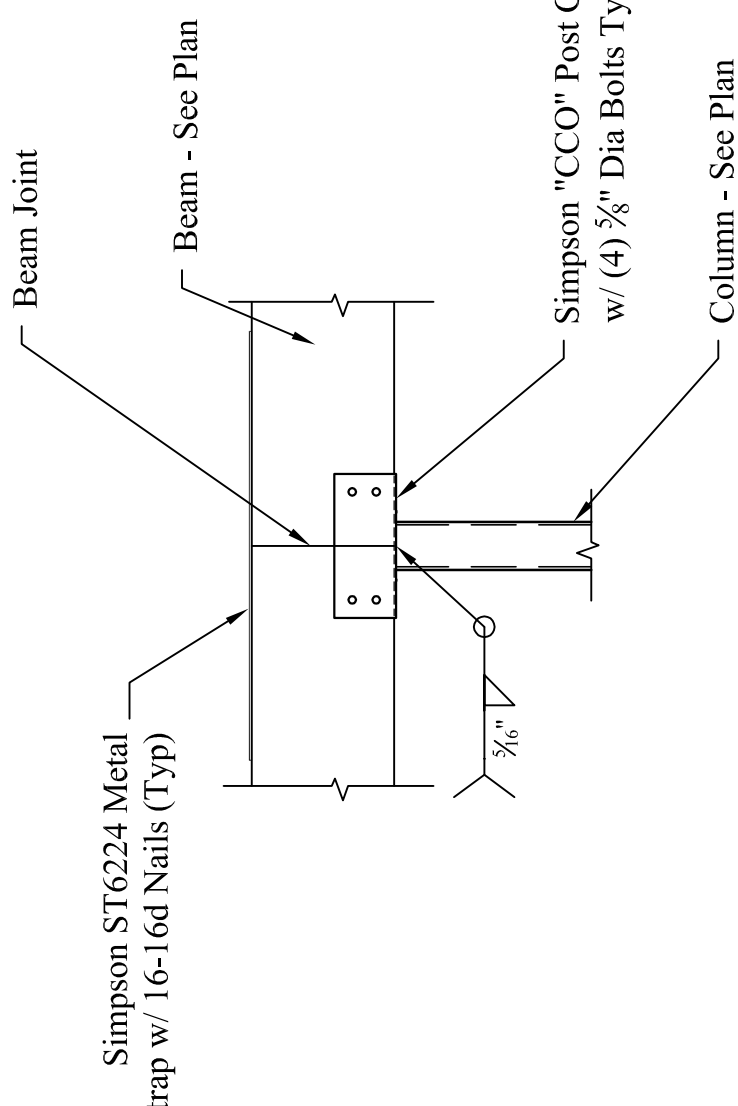

**15 STEEL COLUMN CAP CONN.**  
Scale: 3/4" = 1'-0"

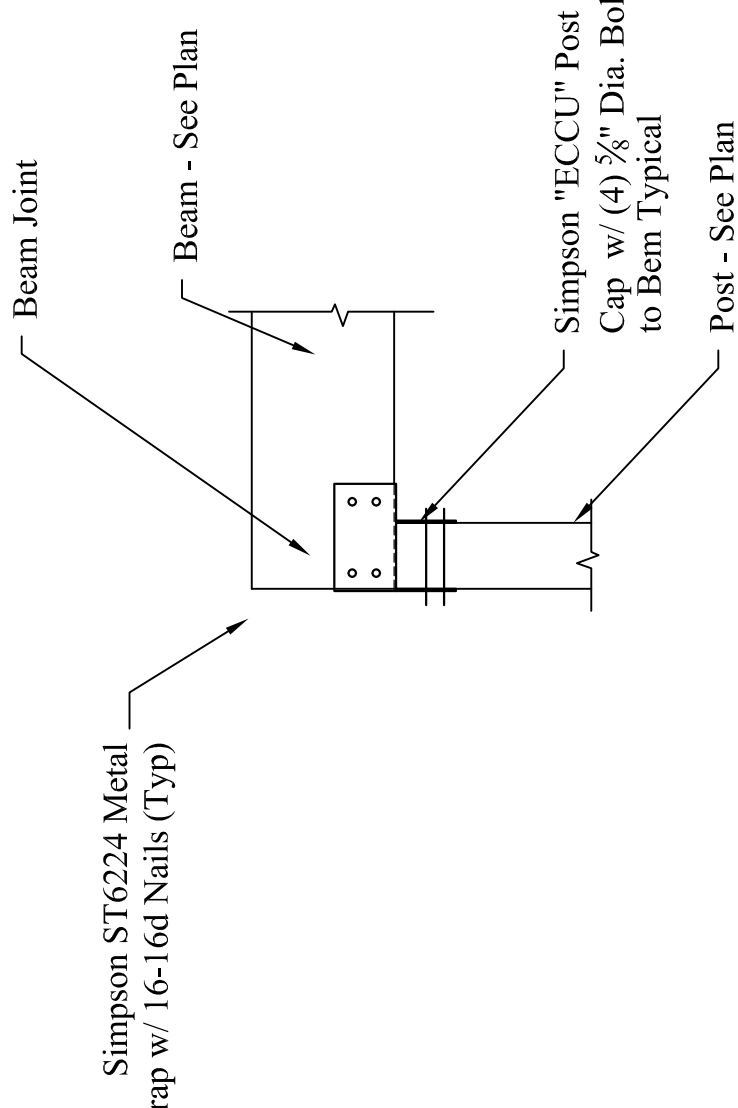

**16 POST TO BEAM CONN.**  
Scale: 3/4" = 1'-0"