

DISPLAY THIS CARD ON PRINCIPAL FRONTAGE OF WORK CITY OF PORTLAND

Please Read Application And Notes, If Any, Attached

BUILDING DEPARTMENT

PERMIT

Permit Number: 070852

This is to certify that COURTOIS LELAND B /Belove

has permission to Replace and repair front steps

AT 65 PINE ST

PERMIT ISSUED
AUG 29 2007
CITY OF PORTLAND

provided that the person or persons, firm or corporation accepting this permit shall comply with all of the provisions of the Statutes of Maine and of the ordinances of the City of Portland regulating the construction, maintenance and use of buildings and structures, and of the application on file in this department.

Apply to Public Works for street line and grade if nature of work requires such information.

Notification of inspection must be given and when permission is procured before this building or part thereof is occupied or closed-in. 24 HOUR NOTICE IS REQUIRED.

A certificate of occupancy must be procured by owner before this building or part thereof is occupied.

OTHER REQUIRED APPROVALS

Fire Dept. Craig Chase

Health Dept. _____

Appeal Board _____

Other _____

Department Name

Thomas W. Manley 7/31/07
Director - Building & Inspection Services

PENALTY FOR REMOVING THIS CARD

City of Portland, Maine - Building or Use Permit Application

389 Congress Street, 04101 Tel: (207) 874-8703, Fax: (207) 874-8716

Permit No: 07-0852	Issue Date:	CBL: 055 B028001
-----------------------	-------------	---------------------

Location of Construction: 65 PINE ST	Owner Name: COURTOIS LELAND B	Owner Address: 55 MONTROSE AVE	Phone:
Business Name:	Contractor Name: Ben Love	Contractor Address: 121 Peter Vier Road Durham	Phone 2077492567
Lessee/Buyer's Name	Phone:	Permit Type: Alterations - Multi Family	Zone: R-6

Past Use: Multi-Family	Proposed Use: Multi-Family - Replace and repair front steps same footprint	Permit Fee: \$30.00	Cost of Work: \$1,000.00	CEO District: 2
<i>legature: 5 dwelling units</i>		FIRE DEPT: <input checked="" type="checkbox"/> Approved <input type="checkbox"/> Denied <i>maintain egress</i>	INSPECTION: Use Group: <i>23</i> Type: <i>SB</i> <i>IBC 2003</i>	

Proposed Project Description: Replace and repair front steps same footprint	Signature: <i>Craig Cass</i>	Signature: <i>Jim 7/31/07</i>
PEDESTRIAN ACTIVITIES DISTRICT (P.A.D.)		
Action: <input type="checkbox"/> Approved <input type="checkbox"/> Approved w/Conditions <input type="checkbox"/> Denied		
Signature: _____ Date: _____		

Permit Taken By: Idobson	Date Applied For: 07/16/2007	Zoning Approval	
-----------------------------	---------------------------------	------------------------	--

1. This permit application does not preclude the Applicant(s) from meeting applicable State and Federal Rules.
2. Building permits do not include plumbing, septic or electrical work.
3. Building permits are void if work is not started within six (6) months of the date of issuance. False information may invalidate a building permit and stop all work..

Special Zone or Reviews <input type="checkbox"/> Shoreland <input type="checkbox"/> Wetland <i>all work w/in existing footprint</i> <input type="checkbox"/> Flood Zone <input type="checkbox"/> Subdivision <input type="checkbox"/> Site Plan Maj <input type="checkbox"/> Minor <input type="checkbox"/> MM <input type="checkbox"/> Date: <i>7/17/07 ok w/ conditions</i>	Zoning Appeal <input type="checkbox"/> Variance <input type="checkbox"/> Miscellaneous <input type="checkbox"/> Conditional Use <input type="checkbox"/> Interpretation <input type="checkbox"/> Approved <input type="checkbox"/> Denied Date: _____	Historic Preservation <i>yes</i> <input type="checkbox"/> Not in District or Landmark <input type="checkbox"/> Does Not Require Review <input type="checkbox"/> Requires Review <input type="checkbox"/> Approved <input checked="" type="checkbox"/> Approved w/Conditions <input type="checkbox"/> Denied Date: <i>7/17/07 SJH</i>
---	---	---

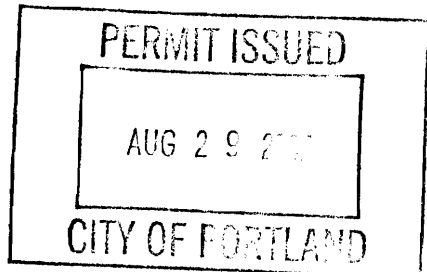

CERTIFICATION

I hereby certify that I am the owner of record of the named property, or that the proposed work is authorized by the owner of record and that I have been authorized by the owner to make this application as his authorized agent and I agree to conform to all applicable laws of this jurisdiction. In addition, if a permit for work described in the application is issued, I certify that the code official's authorized representative shall have the authority to enter all areas covered by such permit at any reasonable hour to enforce the provision of the code(s) applicable to such permit.

SIGNATURE OF APPLICANT	ADDRESS	DATE	PHONE
RESPONSIBLE PERSON IN CHARGE OF WORK, TITLE		DATE	PHONE

City of Portland, Maine - Building or Use Permit

389 Congress Street, 04101 Tel: (207) 874-8703, Fax: (207) 874-8716

Permit No: 07-0852	Date Applied For: 07/16/2007	CBL: 055 B028001
------------------------------	--	----------------------------

Location of Construction: 65 PINE ST	Owner Name: COURTOIS LELAND B	Owner Address: 55 MONTROSE AVE	Phone:
Business Name:	Contractor Name: Ben Love	Contractor Address: 121 Peter Vier Road Durham	Phone: (207) 749-2567
Lessee/Buyer's Name	Phone:	Permit Type: Alterations - Multi Family	

Proposed Use: Multi-Family - 5 dwelling units - Replace front steps - same footprint	Proposed Project Description: Replace front steps - same footprint
--	--

Dept: Historic **Status:** Approved with Conditions **Reviewer:** Scott Hanson **Approval Date:** 07/18/2007
Note: **Ok to Issue:**

- 1) • That the stairs be rebuilt at the same width.
- That the stair sides be enclosed with framed square lattice skirting.
- Pressure-treated wood shall not be used on any finished surfaces, including treads.
- That the tread/riser and skirting details to follow the City's porch replacement specifications (attached).
- All exposed surfaces, including treads, to be painted.

Dept: Zoning **Status:** Approved with Conditions **Reviewer:** Ann Machado **Approval Date:** 07/17/2007
Note: **Ok to Issue:**

- 1) This permit is being approved on the basis of plans submitted. Any deviations shall require a separate approval before starting that work.
- 2) This property shall remain a five family dwelling. Any change of use shall require a separate permit application for review and approval.
- 3) ANY exterior work requires a separate review and approval thru Historic Preservation. This property is located within an Historic District.
- 4) This permit is being issued with the condition that all work will take place within the existing footprint.

Dept: Building **Status:** Approved with Conditions **Reviewer:** Tom Markley **Approval Date:** 07/31/2007
Note: **Ok to Issue:**

- 1) Permit approved based on the plans submitted and reviewed w/owner/contractor, with additional information as agreed on and as noted on plans.
- 2) Must stay within same footprint. Treads and risers will not be too Code Requirements.

Dept: Fire **Status:** Approved with Conditions **Reviewer:** Capt Greg Cass **Approval Date:** 07/19/2007
Note: **Ok to Issue:**

- 1) Maintain egress at all times building is occupied.



General Building Permit Application

If you or the property owner owes real estate or personal property taxes or user charges on any property within the City, payment arrangements must be made before permits of any kind are accepted.

Location/Address of Construction: <u>5 Pine St</u>		
Total Square Footage of Proposed Structure <u>390 Sq. ft.</u>	Square Footage of Lot <u>± 5280 Sq. ft.</u>	
Tax Assessor's Chart, Block & Lot Chart# <u>55</u> Block# <u>B</u> Lot# <u>28</u>	Owner: <u>Leland Bruce Courtois</u>	Telephone: <u>773-4820</u>
Lessee/Buyer's Name (If Applicable)	Applicant name, address & telephone: <u>Leland Bruce Courtois</u> <u>55 Montrose Ave</u> <u>Portland ME 04103</u>	Cost Of Work: \$ <u>1,000.</u> Fee: \$ <u>30</u> C of O Fee: \$ <u>N/A</u>
Current legal use (i.e. single family) <u>5 Unit</u>		
If vacant, what was the previous use? _____		
Proposed Specific use: _____		
Is property part of a subdivision? <u>NO</u> If yes, please name _____		
Project description: <u>Replace front steps exactly the way they are using same foot print. Will use presurized lumber (NOT FOR TREADS)</u>		
Contractor's name, address & telephone: <u>Ben Love 101 Peter Vier Rd. Durham</u> <u>749-2567 04222</u>		
Who should we contact when the permit is ready: <u>Owner</u>		
Mailing address: _____ Phone: _____		

Please submit all of the information outlined in the Commercial Application Checklist. Failure to do so will result in the automatic denial of your permit.

In order to be sure the City fully understands the full scope of the project, the Planning and Development Department may request additional information prior to the issuance of a permit. For further information visit us on-line at www.portlandmaine.gov, stop by the Building Inspections office, room 315 City Hall or call 874-8703.

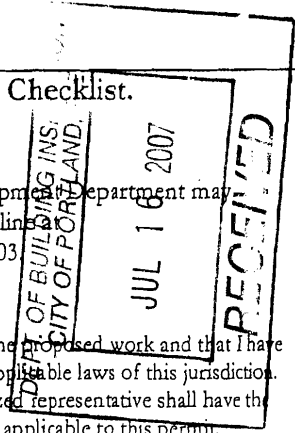

I hereby certify that I am the Owner of record of the named property, or that the owner of record authorizes the proposed work and that I have been authorized by the owner to make this application as his/her authorized agent. I agree to conform to all applicable laws of this jurisdiction. In addition, if a permit for work described in this application is issued, I certify that the Code Official's authorized representative shall have the authority to enter all areas covered by this permit at any reasonable hour to enforce the provisions of the codes applicable to this permit.



Signature of applicant: <u>Leland Bruce Courtois</u>	Date: <u>July 16, 2007</u>
--	----------------------------

This is not a permit; you may not commence ANY work until the permit is issued.

Allowed to replace in kind
for treads + risers (historic)
MUST STAY in same footprint.

FINIAL → 
CAP → 

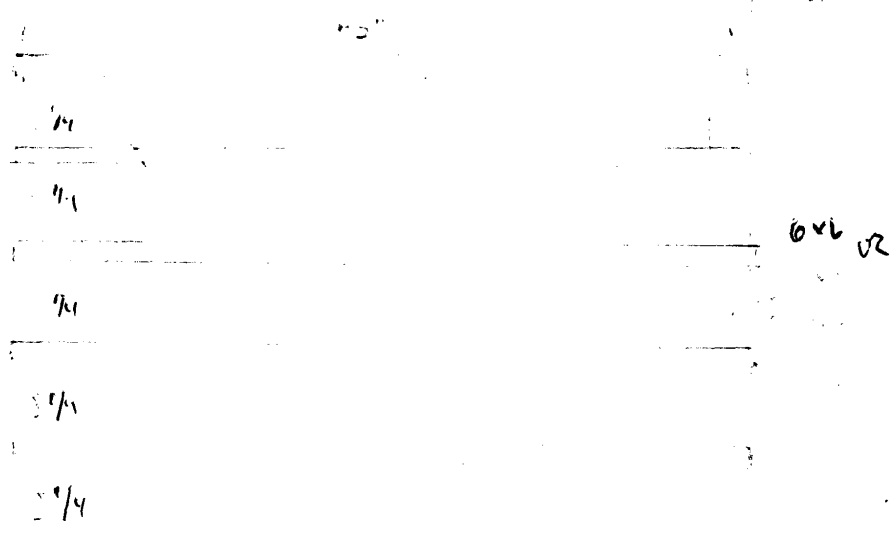
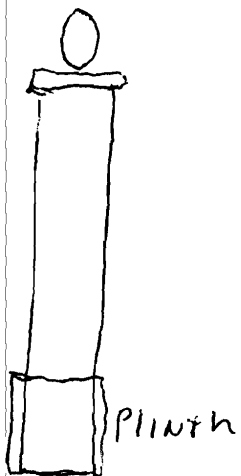
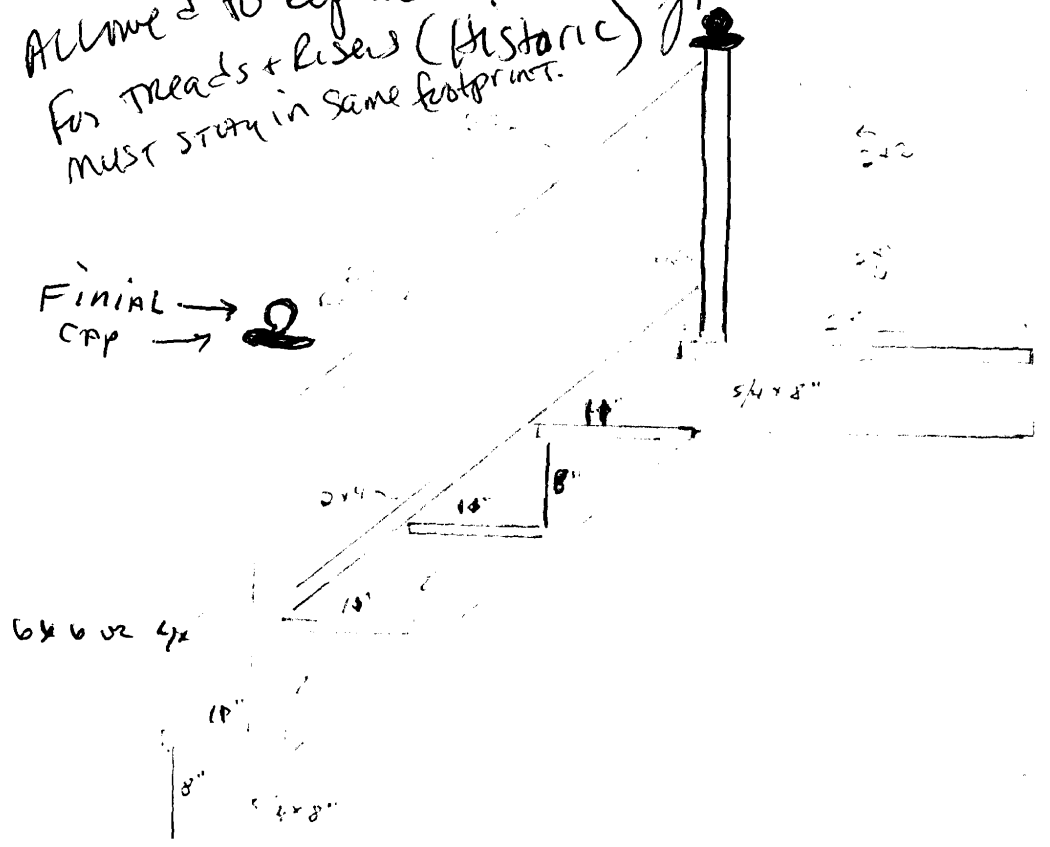

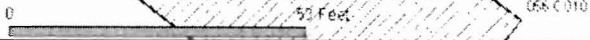
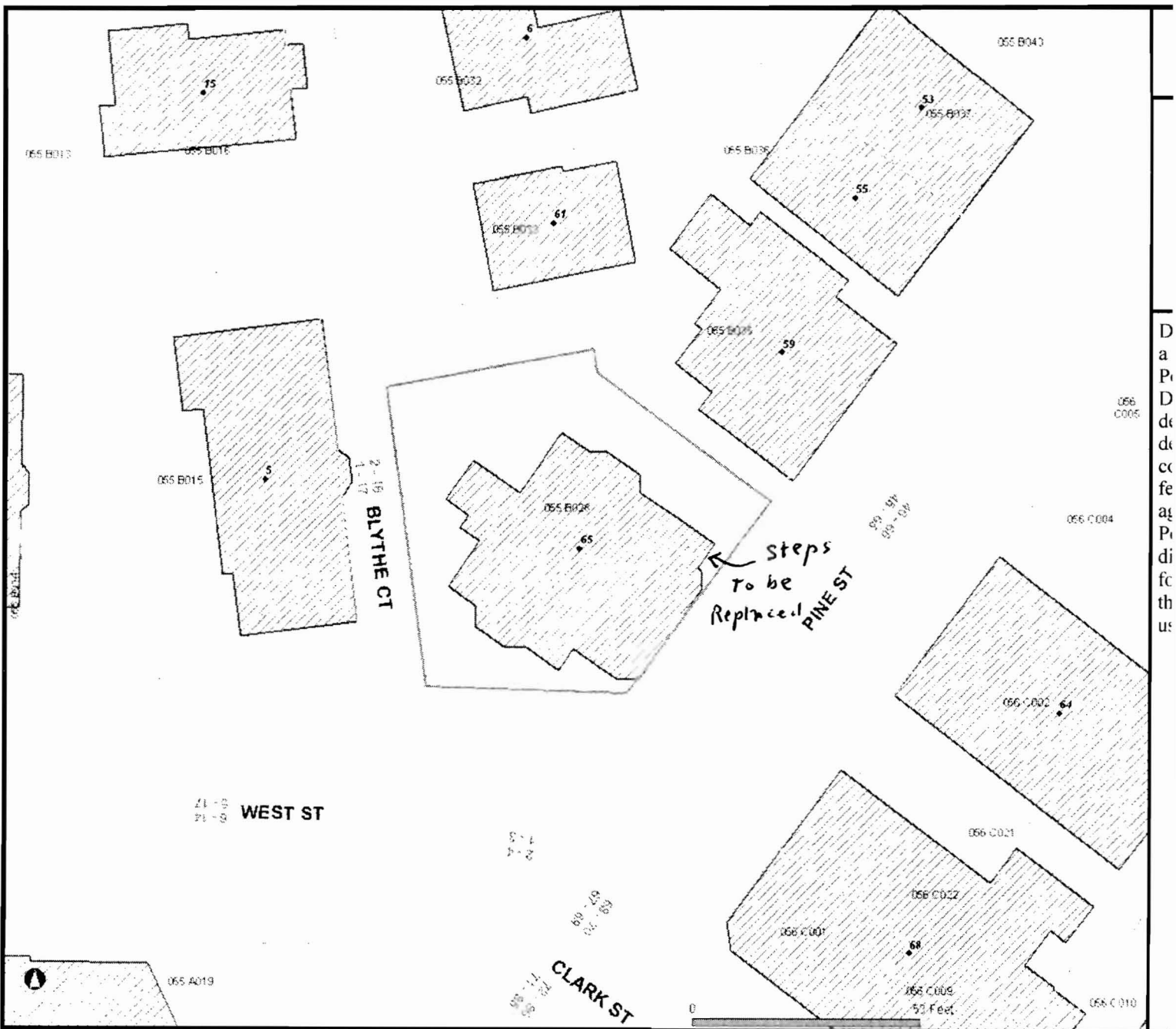

STAIR DETAILS FOR RESIDENTIAL USE

Typical residential risers and treads

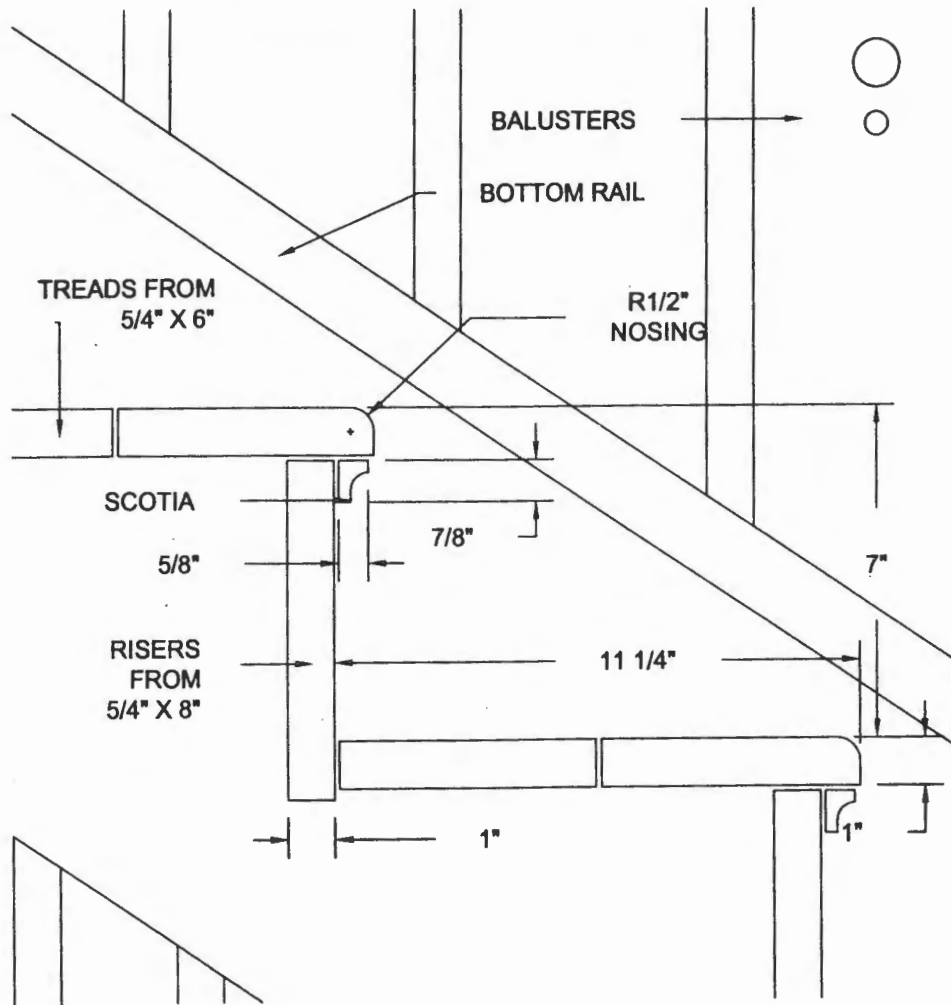

Typical newel post construction

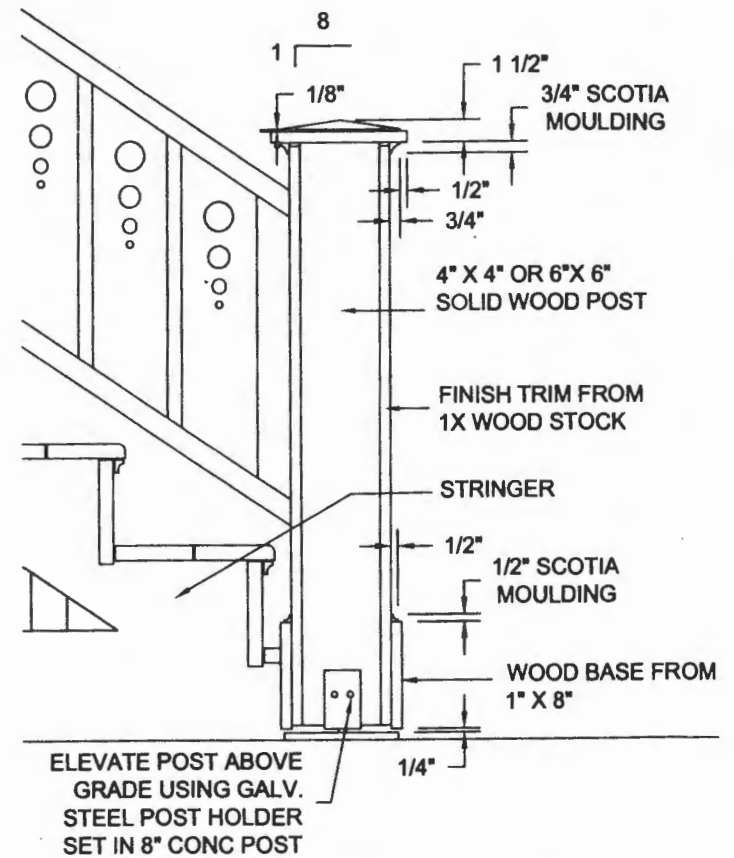

Alternate: Newel post may be bolted to a stringer.

COLONIAL REVIVAL DETAILS

Colonial Revival newel posts

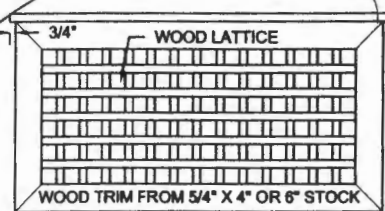
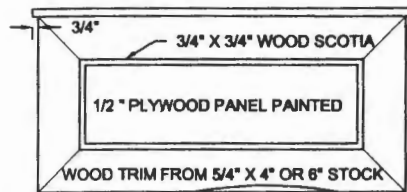
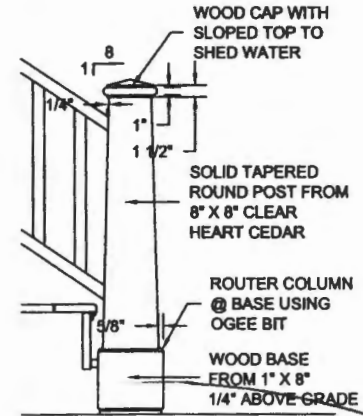
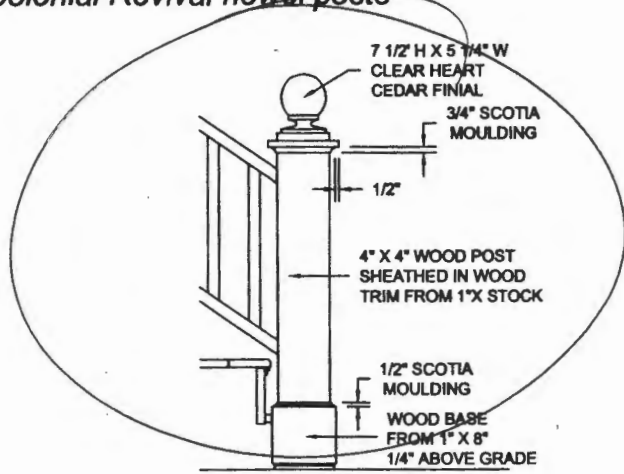

Colonial Revival porch skirting

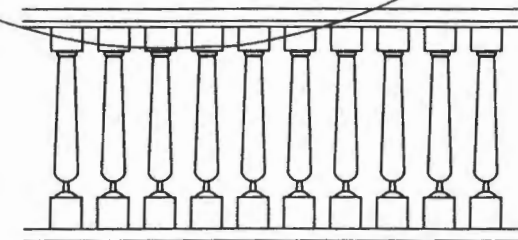
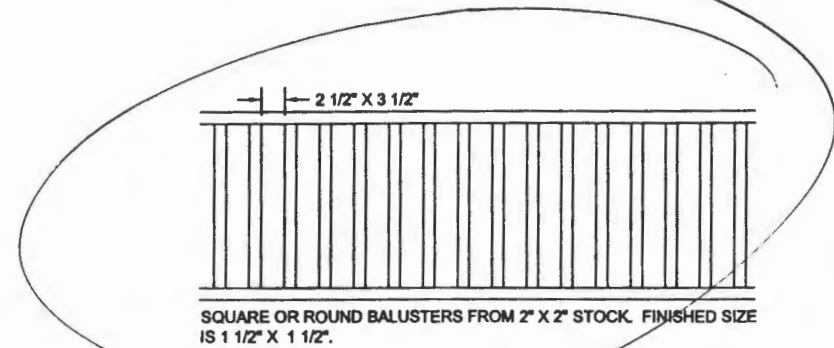

Colonial Revival baluster

