

project name

butler payson
pine street
state street
portland, maine

Avesta Housing

goduti/thomas architects

44 oak st.

portland, maine 04101

ph. 207-775-3184

fax 207-774-0846

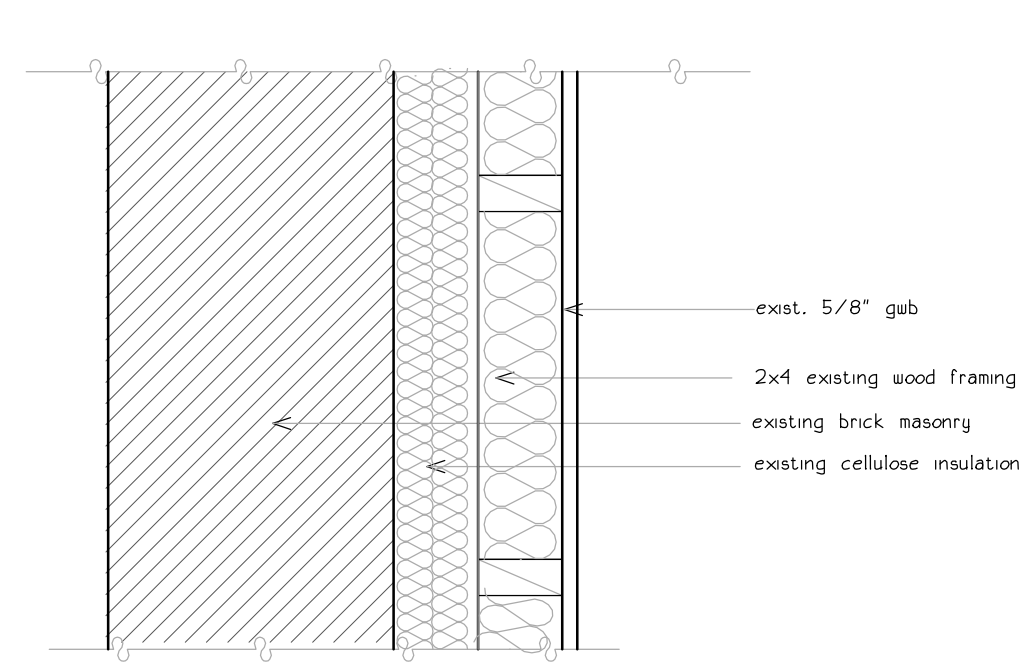

1 existing exterior wall

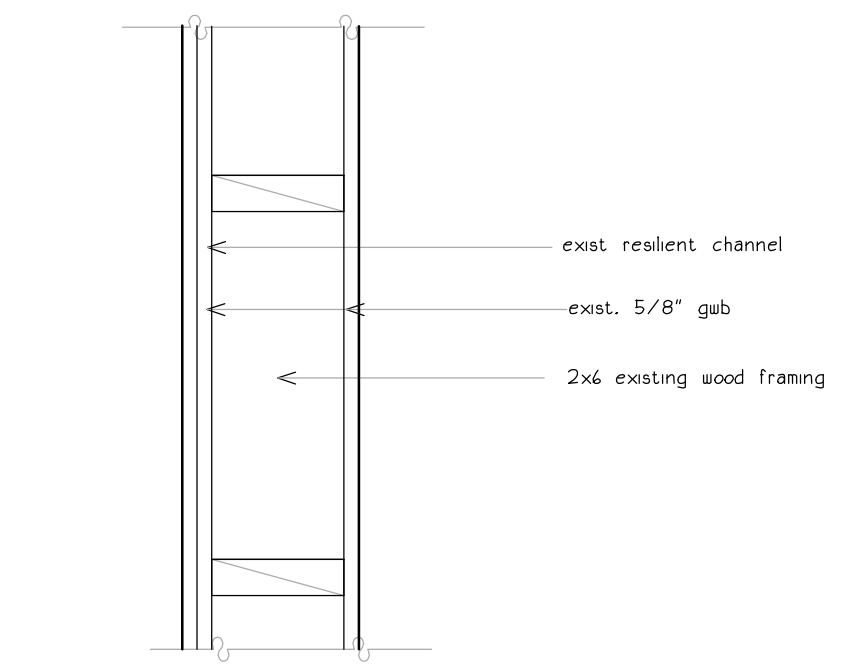

2 existing corridor wall
1 hr rated

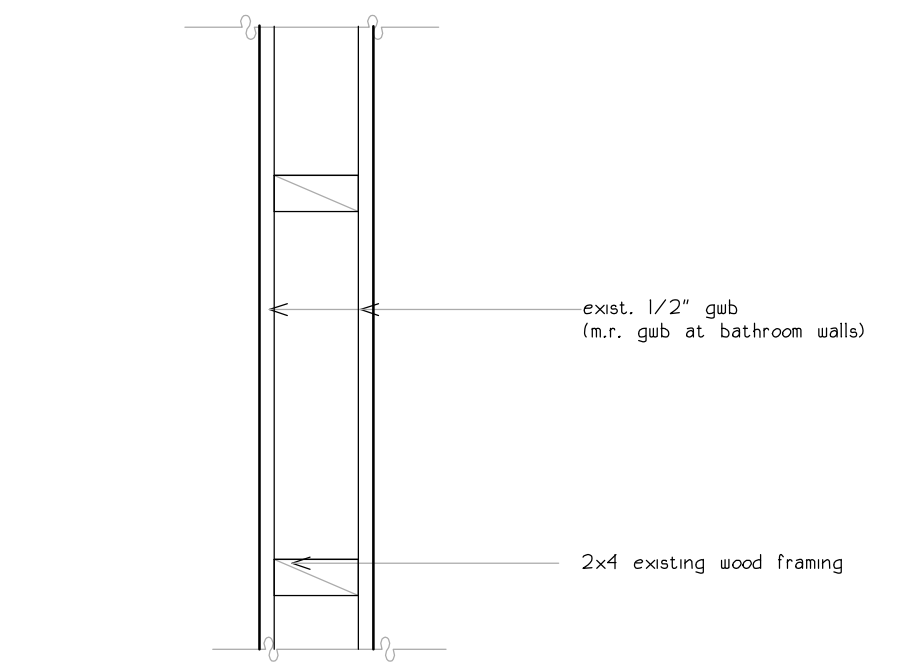

3 existing interior unit wall

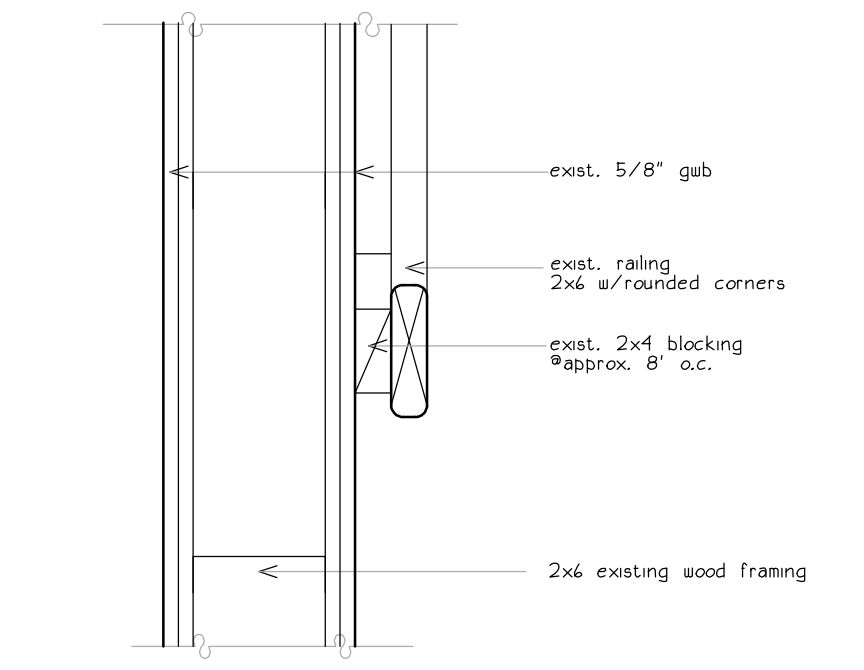

4 existing stair wall/handrail section
2 hr rated

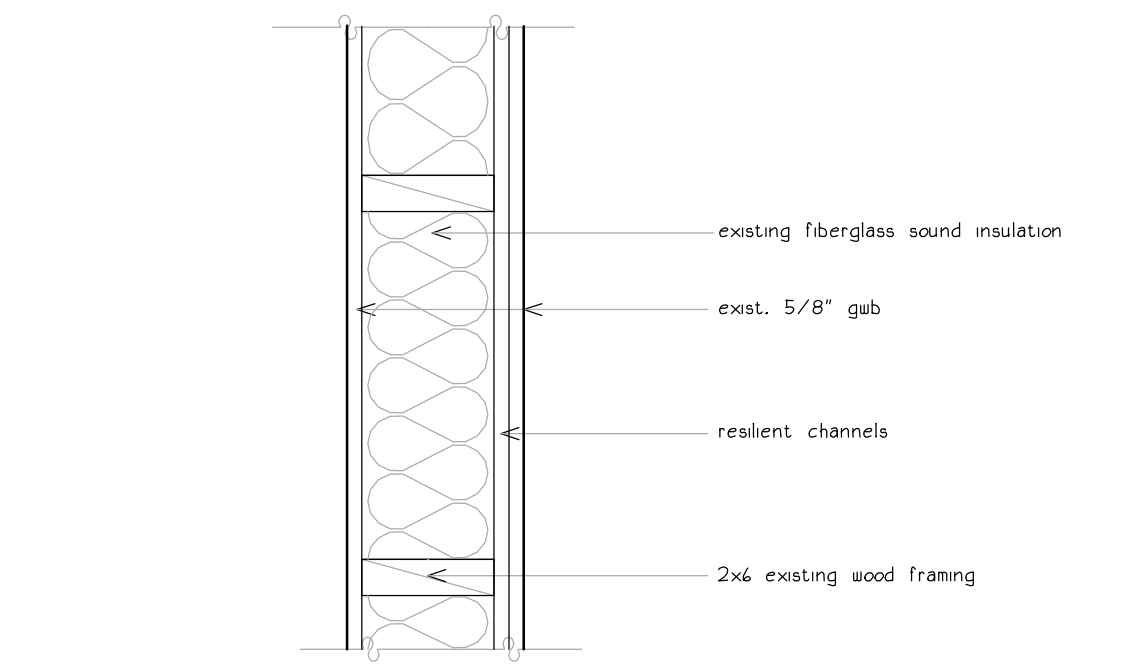

5 existing unit division partition
1 hr rated

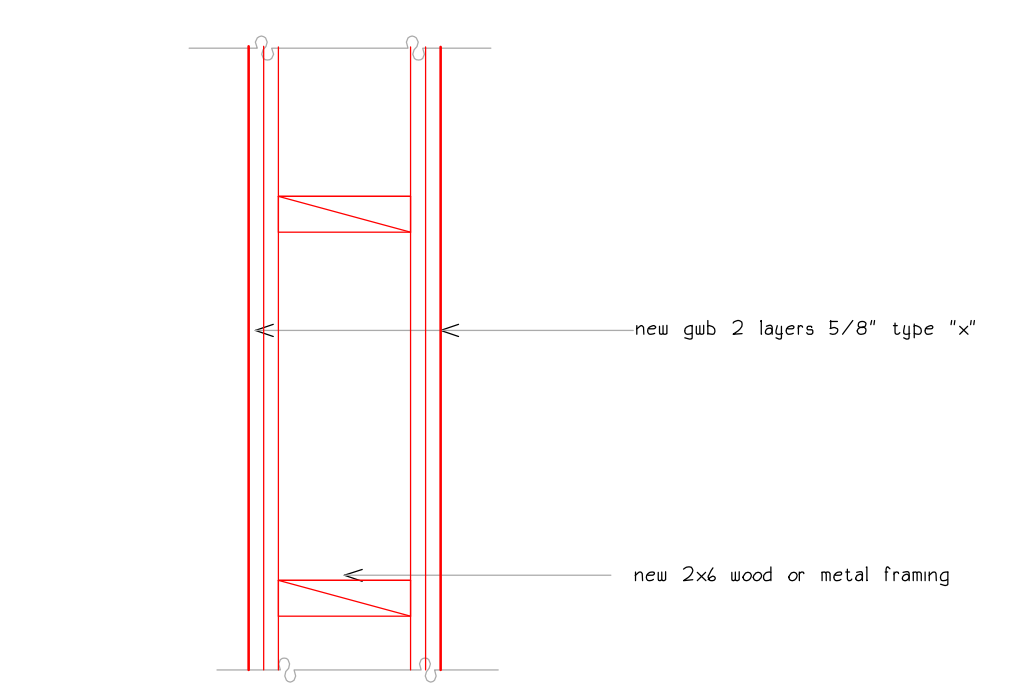

6 new stair wall
2 hr rated

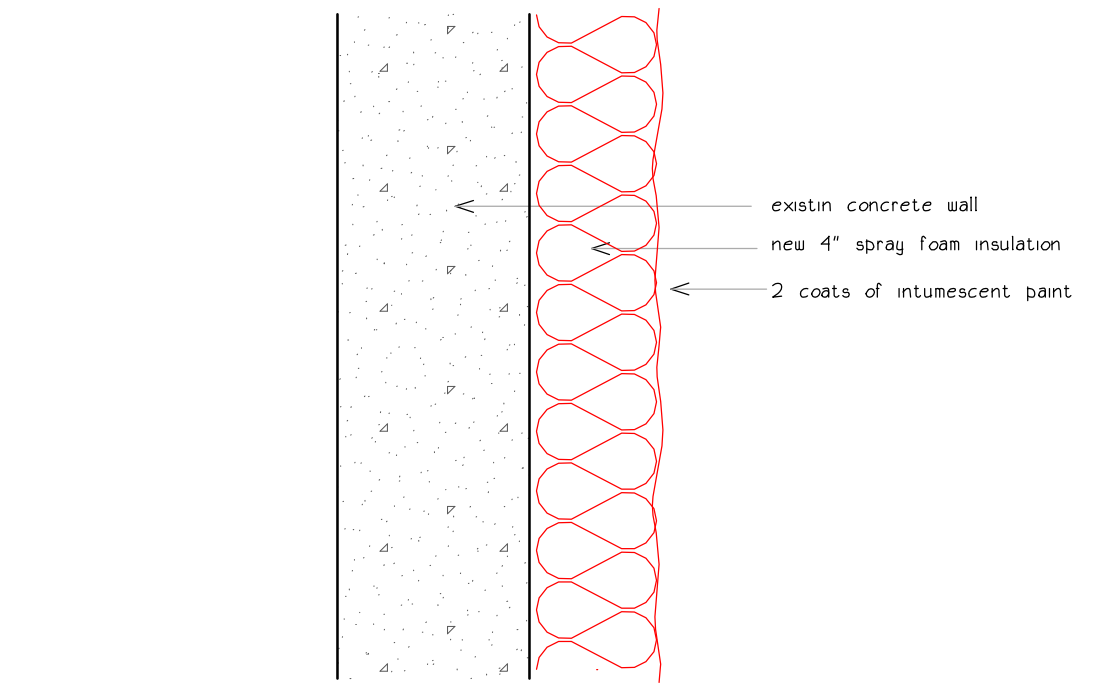

7 crawl space
plan

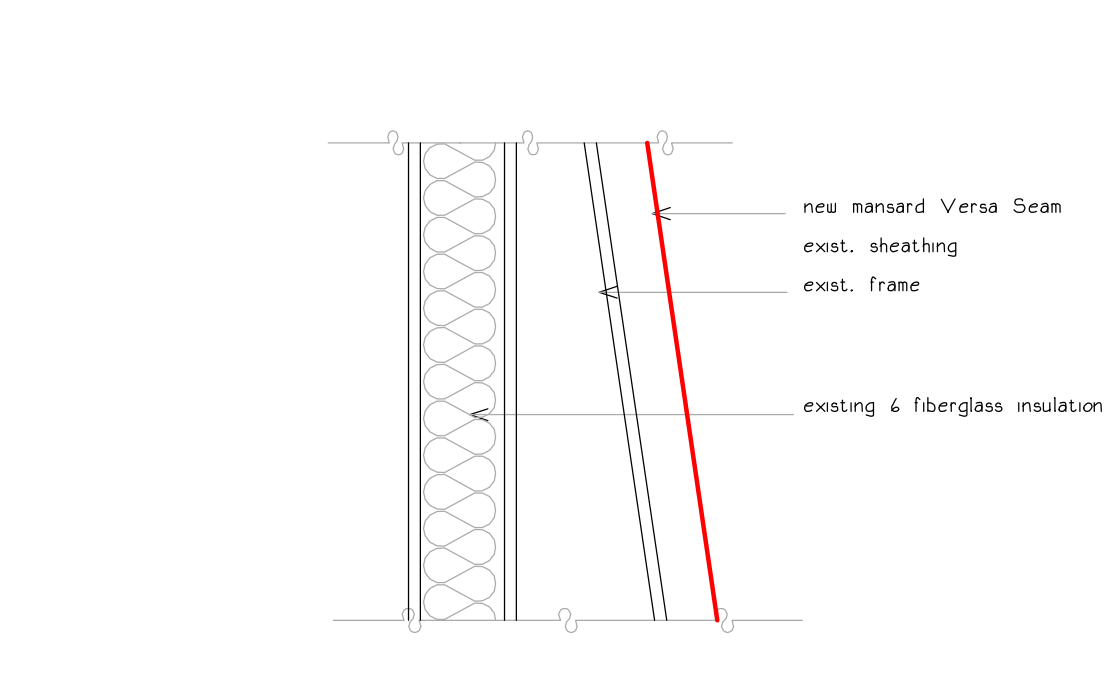

8 3rd floor mansard
section

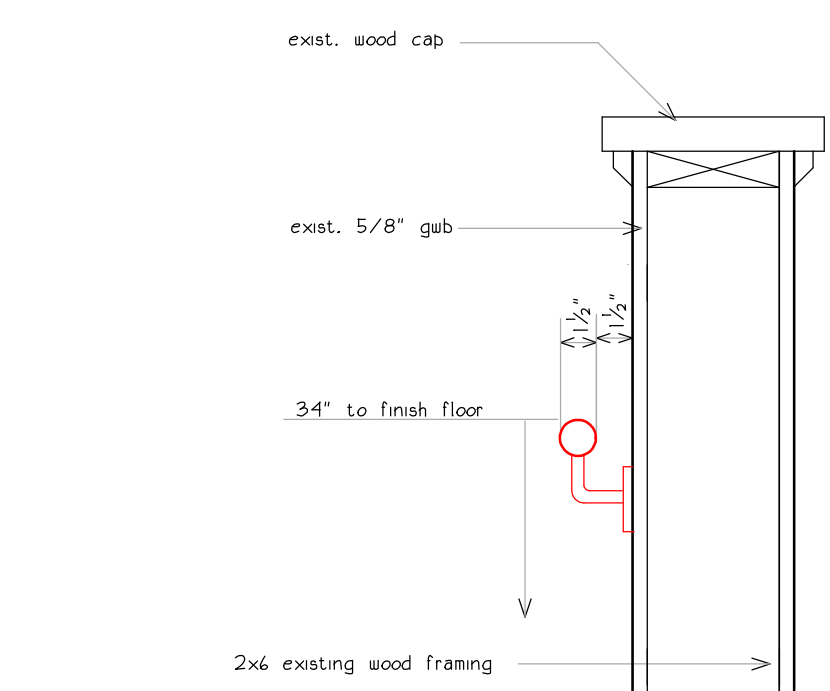

9 railing at ramp
section

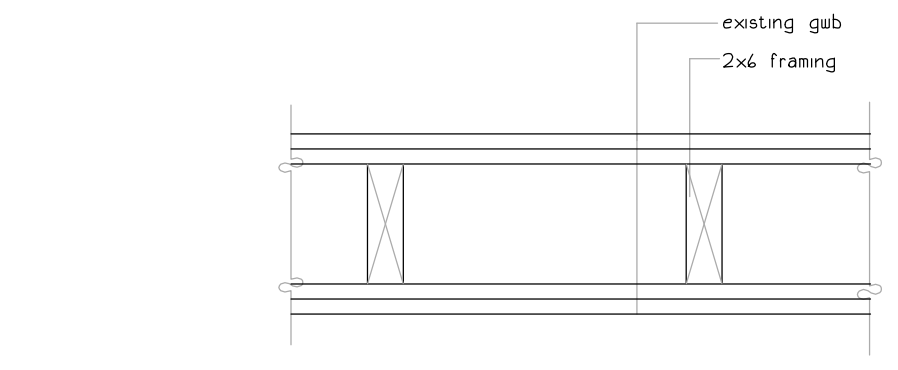

10 elevator pent house
(presumed 2hr)

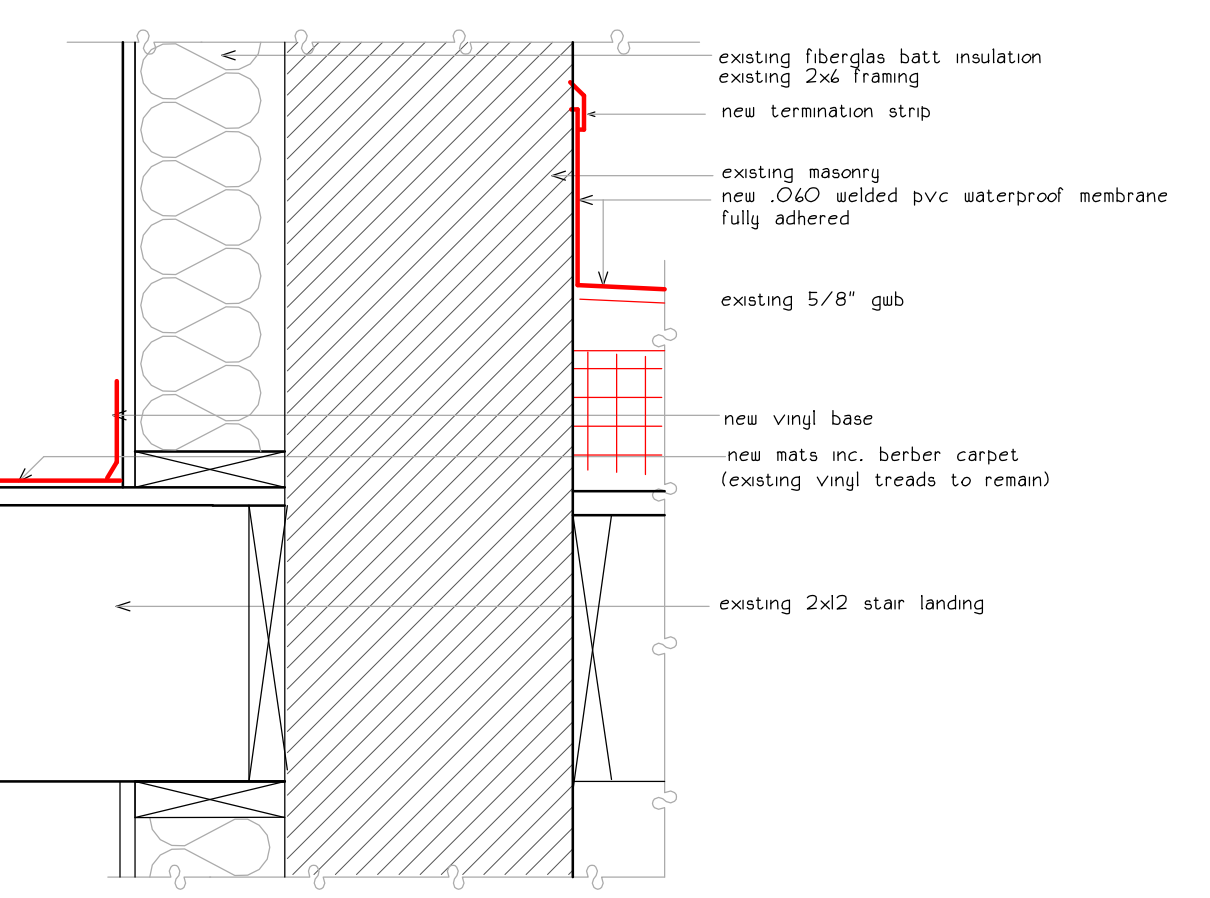

11 stair at 4th floor exterior
(presumed 2hr)

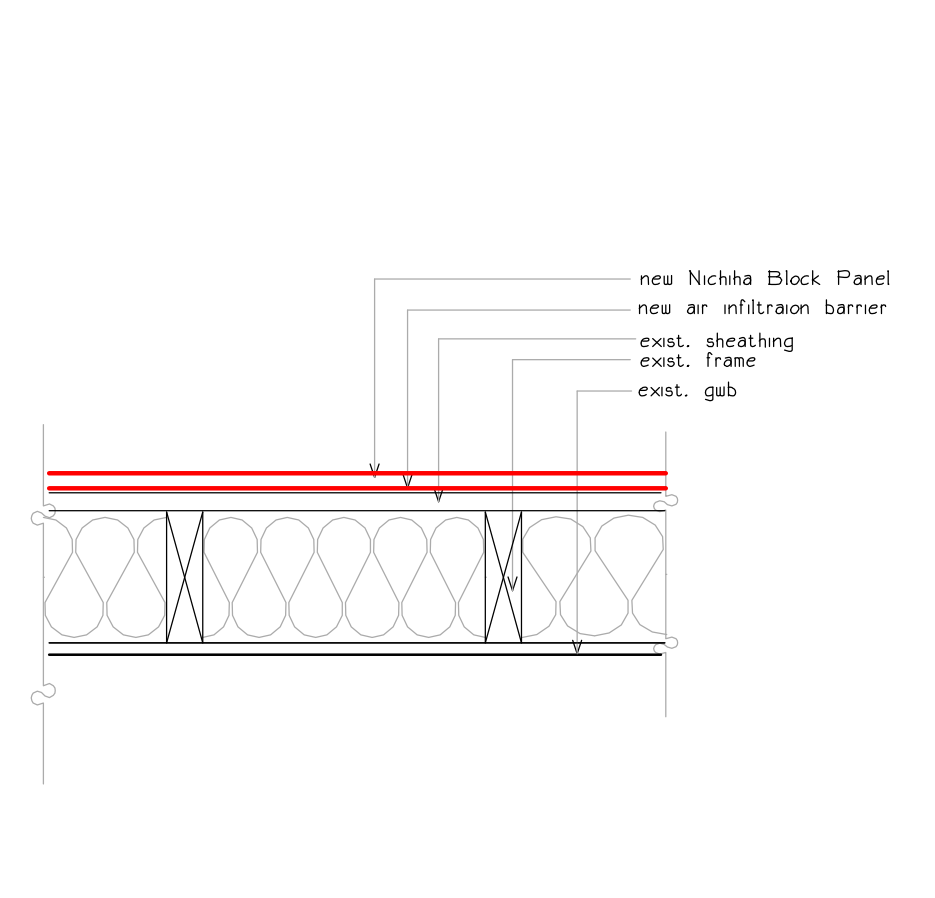

12 corridor at auditorium units
plan

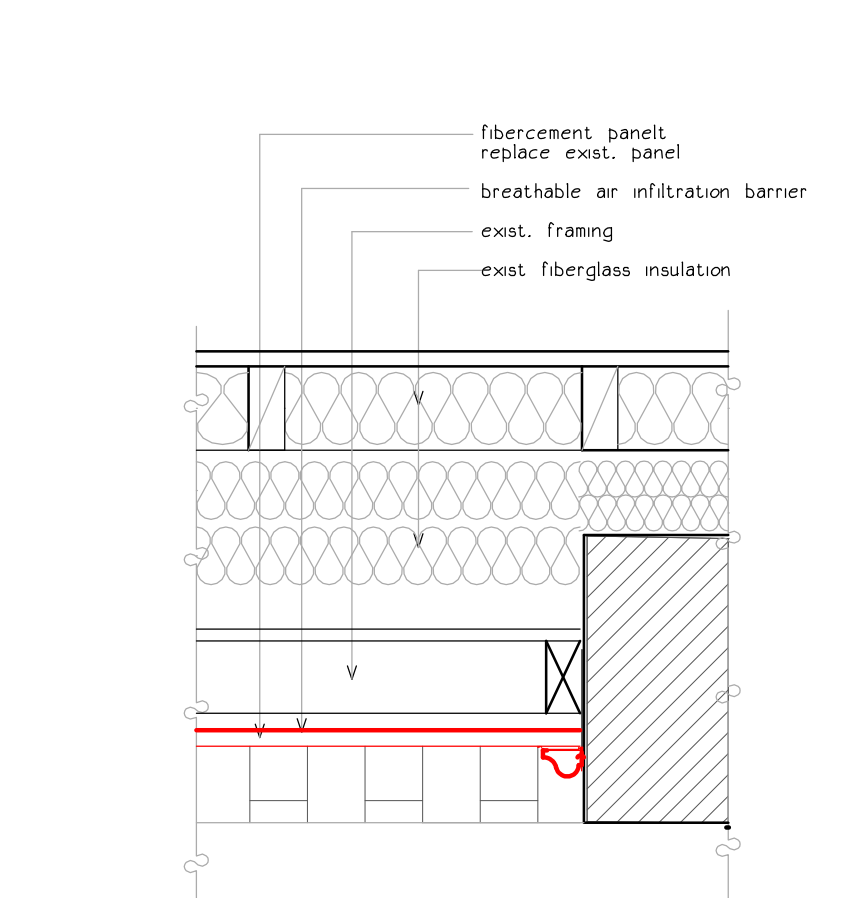

13 fiber cement panels below windows
plan at jamb exist masonry jamb

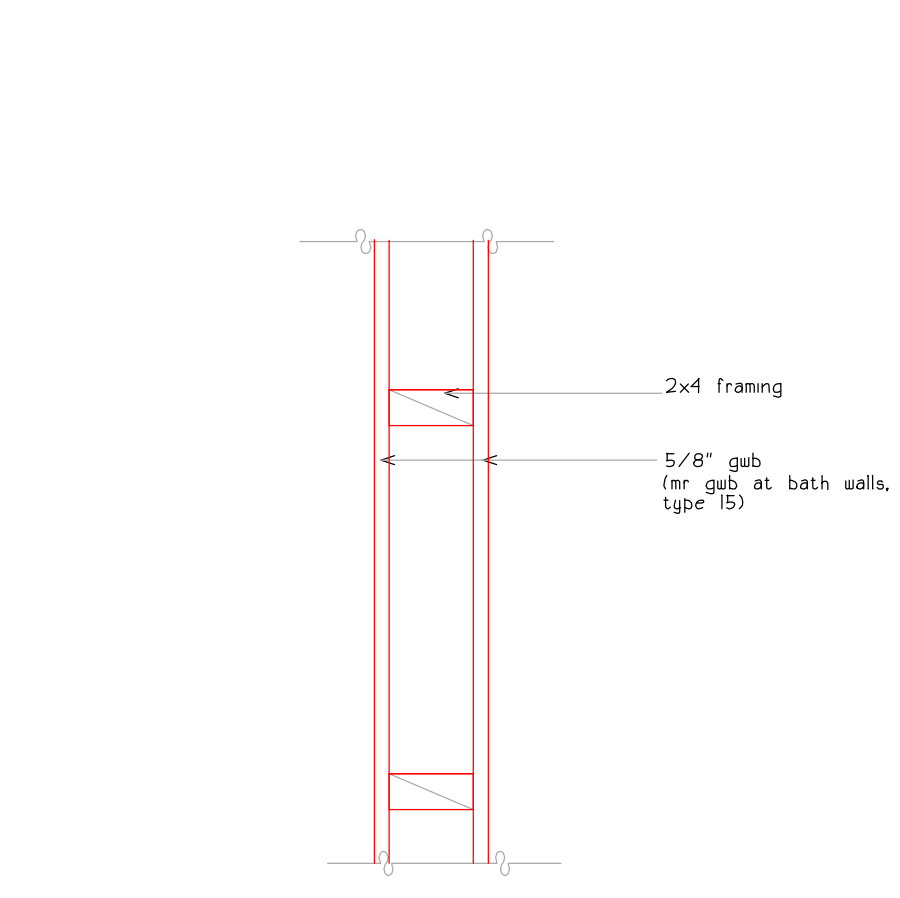

14 new wall at units
plan
15 new wall baths (mr gw) b

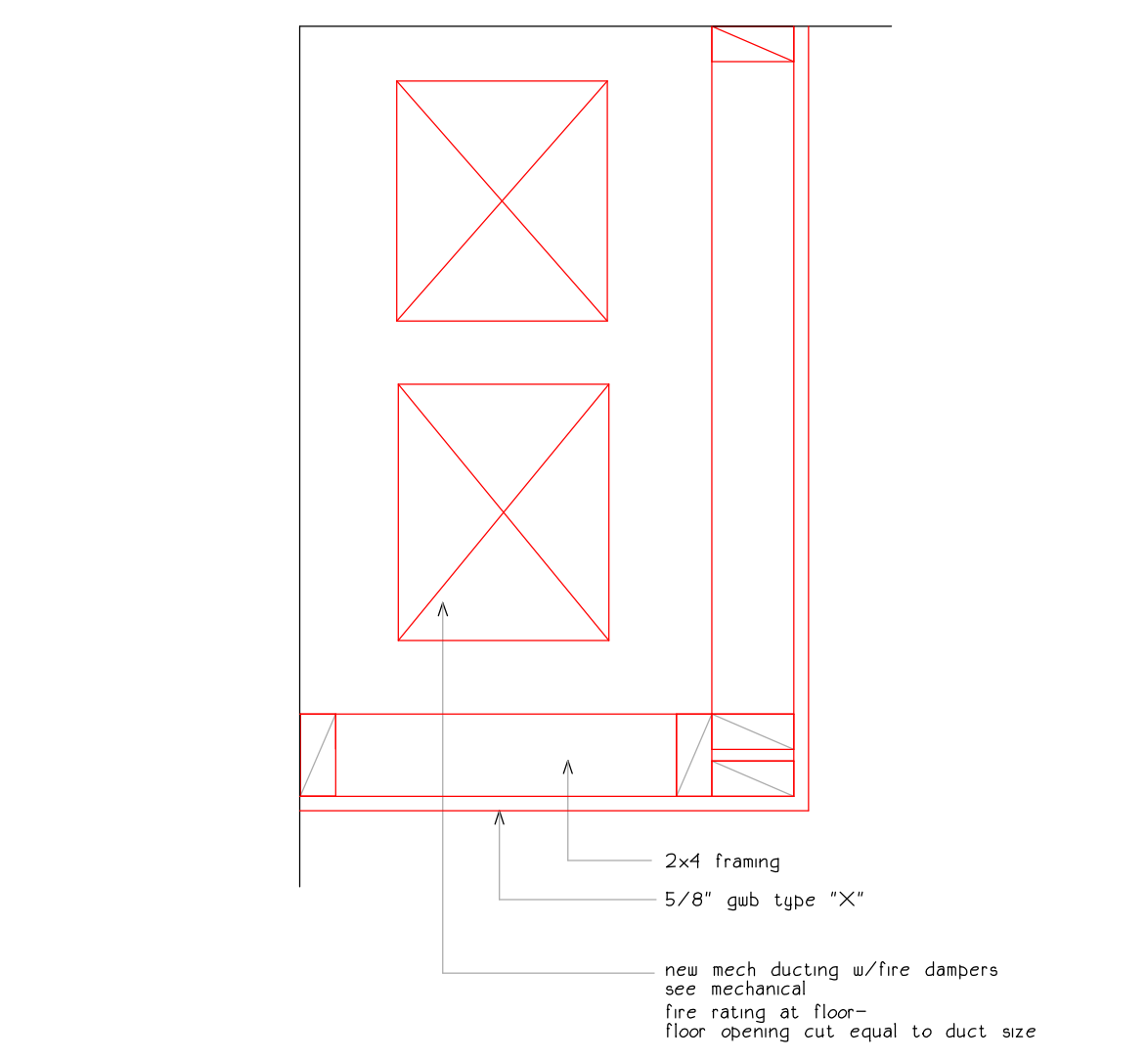

16 new duct enclosure
plan view, see mechanical

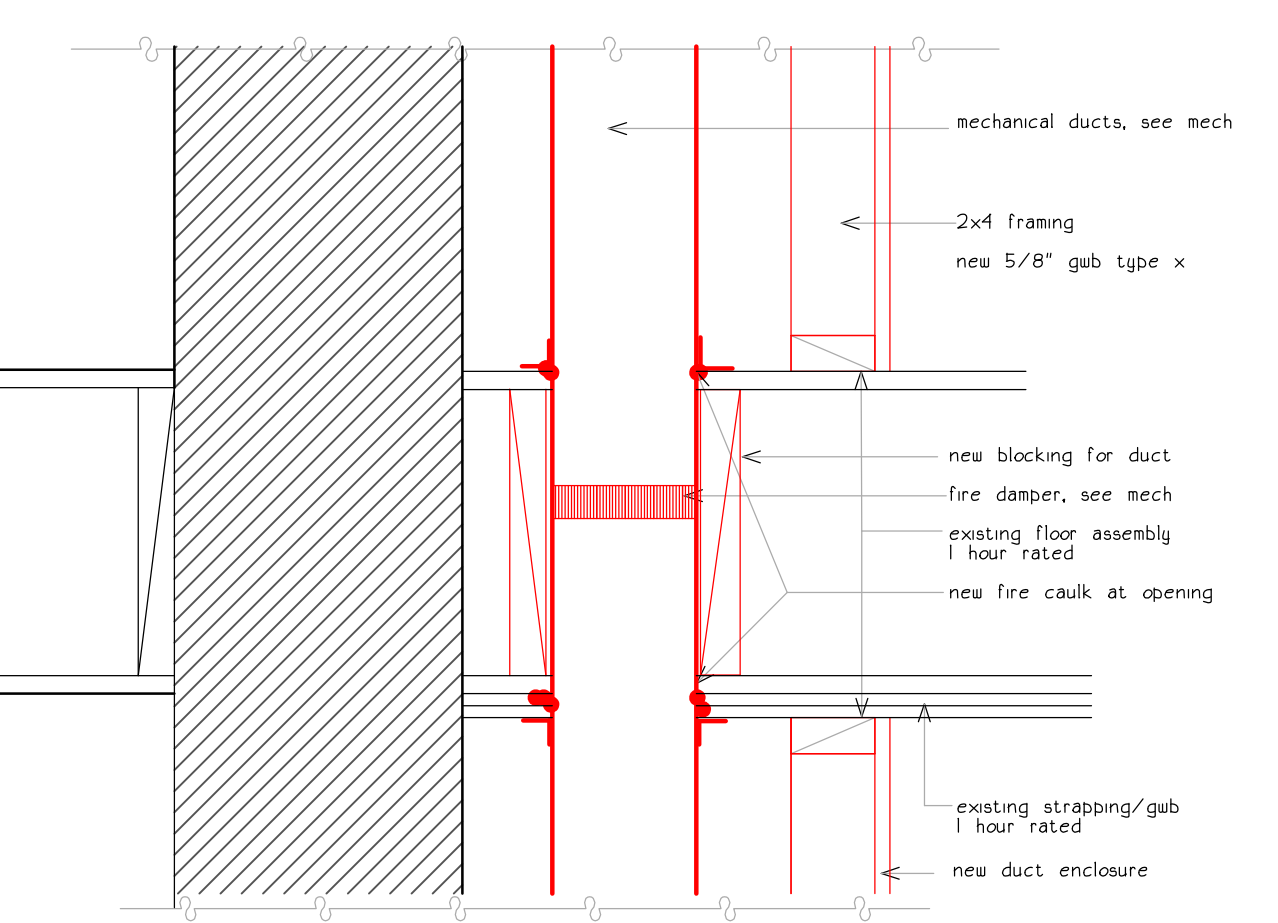

16a new duct enclosure, 1hr rating at floor
section view, see mechanical

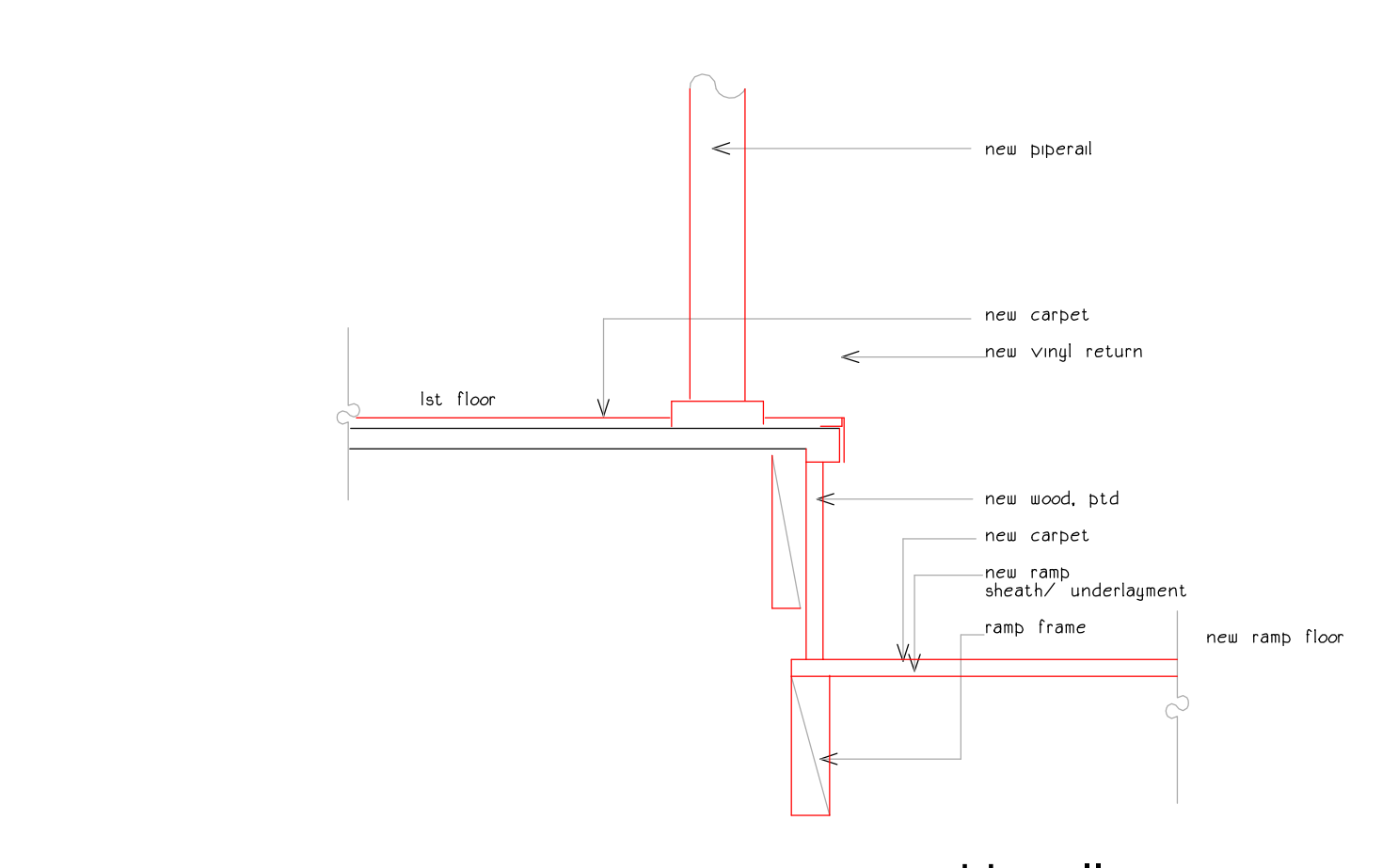

17 ramp sidewall

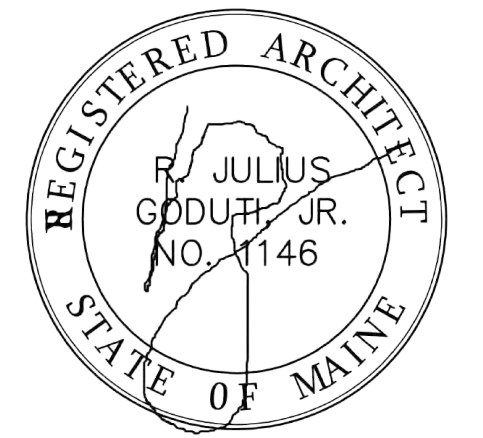

3/30/2015: revised det. 16, 16a
3/16/2015: det 17

revisions

date

march 26, 2015

sheet title

wall types

section views unless noted

scale

1 1/2" = 1'-0"

drawn by

RG

project number

sheet number

BA5.7