

Installation Instructions

for use by heating contractor

VIESSMANN

Common venting with flue vent damper
for Vitocrossal 200 CM2 series equipped
with Vitotronic 300 GW5B/GW6B

Common Venting with Flue Vent Damper

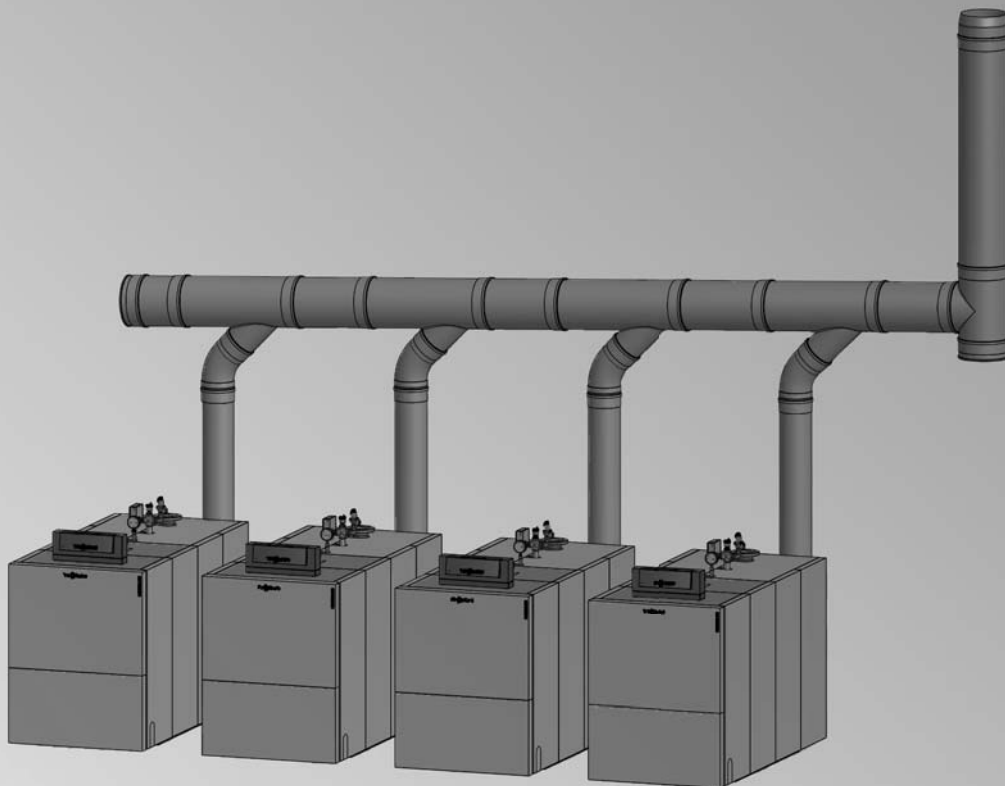

Product may not be exactly as shown

IMPORTANT

**Read and save these instructions
for future reference.**

Safety, Installation and Warranty Requirements

Please ensure that these instructions are read and understood before commencing installation. Failure to comply with the instructions listed below and details printed in this manual can cause product/property damage, severe personal injury, and/or loss of life. Ensure all requirements below are understood and fulfilled (including detailed information found in manual subsections).

- **Licensed professional heating contractor**
 The installation, adjustment, service and maintenance of this equipment must be performed by a licensed professional heating contractor.

► *Please see section entitled "Important Regulatory and Installation Requirements" in the Installation Instructions.*

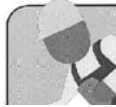

- **Product documentation**
 Read all applicable documentation before commencing installation. Store documentation near boiler in a readily accessible location for reference in the future by service personnel.

► *For a listing of applicable literature, please see section entitled "Important Regulatory and Safety Requirements" in the Installation Instructions.*



- **Carbon monoxide**
 Improper installation, adjustment, service and/or maintenance can cause flue products to flow into living space. Flue products contain poisonous carbon monoxide gas.

► *For information pertaining to the proper installation, adjustment, service and maintenance of this equipment to avoid formation of carbon monoxide, please read these Installation Instructions carefully.*



- **Equipment venting**
 Never operate boiler without an installed venting system. An improper venting system can cause carbon monoxide poisoning.

- **Warranty**
 Information contained in this and related product documentation must be read and followed. Failure to do so renders the warranty null and void.



- **Advice to owner**
 Once the installation work is complete, the heating contractor must familiarize the system operator/ultimate owner with all equipment, as well as safety precautions/requirements, shutdown procedure, and the need for professional service annually before the heating season begins.

! WARNING

Installers must follow local regulations with respect to installation of carbon monoxide detectors. Follow manufacturer's maintenance schedule boiler.

	Page
Safety	
	Safety, Installation and Warranty Requirements.....2
	Important Regulatory and Installation Requirements.....4
	About these Installation Instructions.....5
Venting	
	General Venting Information.....6
	Requirements for UL/ULC Listed Rigid SS/PP(s)
	Vent Pipe Material.....9
	Venting Requirements.....10
Installation	
	Clearances.....11
	Dimensions.....12
	Venting Layout.....13
	Removing the Junction Box Cover.....15
	Removing the Front Panel (CM2-186, 246 and -311)....15
	Removing the Top Front Panel
	(CM2-400, 500, 620 and -620 TX).....16
	Removing the Bottom Front Panel
	(CM2-400, 500, 620 and -620 TX).....16
	Removing the Side Panels.....17
	Installing the Flue Vent Damper.....18
	Removing the Top Panels - Vitotronic 300 GW5B.....19
	Routing the Flue Vent Damper Cabling
	- Vitotronic 300 GW5B.....19
	Connecting the Flue Vent Damper Cable to the
	Burner Control - Vitotronic 300 GW5B.....20
	Installing the Top Panels - Vitotronic 300 GW5B.....20
	Installing the Flue Vent Damper Wiring to the
	Junction Box - Vitotronic 300 GW5B.....21
	Connecting the Flue Vent Damper Cable to the
	Burner Control - Vitotronic 300 GW5B.....21
	Installing the Flue Vent Damper Wiring to the
	Junction Box - Vitotronic 300 GW5B.....22
	Connecting the Flue Vent Damper Cable to the
	Junction Box - Vitotronic 300 GW5B.....22
	Installing the Flue Vent Damper Wiring to the
	Junction Box - Vitotronic 300 GW6B.....23
	Connecting the Flue Vent Damper Cable to the
	Junction Box - Vitotronic 300 GW6B.....23
	Burner Control Unit.....24
	Installing the Junction Box Cover.....25
	Installing the Side Panels.....25
	Installing the Front Panel (CM2-186, 246 and -311).....26
	Installing the Front Panels
	(CM2-400, 500, 620 and -620 TX).....26
Venting Examples	
	Common Venting with Vertical Connections.....27
	Common Venting with 45° Connections.....28
	Common Venting with 90° Connections.....29
Specifications	
	Flue Vent Damper.....30

Important Regulatory and Installation Requirements

Approvals

Viessmann boilers, burners and controls are approved for sale in North America by CSA International.

Codes

The installation of this unit shall be in accordance with local codes. In the absence of local codes, use:

- CSA C22.1 Part 1 and/or local codes in Canada
- National Electrical Code ANSI/NFPA 70 in the U.S.

Always use latest editions of codes.

The heating contractor must comply with the Standard for Controls and Safety Devices for Automatically Fired Boilers, ANSI/ASME CSD-1 where required by the authority having jurisdiction.

Working on the equipment

The installation, adjustment, service, and maintenance of this product must be done by a licensed professional heating contractor who is qualified and experienced in the installation, service, and maintenance of hot water boilers. There are no user serviceable parts on the boiler, burner, or control.

Power supply

Install power supply in accordance with the regulations of the authorities having jurisdiction or, in absence of such requirements, in accordance with National Codes. Viessmann recommends the installation of a disconnect switch to the 120V power supply outside of the boiler room.

Ensure main power supply to equipment, the heating system, and all external controls have been deactivated. Close main oil or gas supply valve. Take precautions in both instances to avoid accidental activation of power during service work.

- ▶ Please carefully read this manual prior to attempting installation. Any warranty is null and void if these instructions are not followed.

For information regarding other Viessmann System Technology componentry, please reference documentation of the respective product.

We offer frequent installation and service seminars to familiarize our partners with our products. Please inquire.

- ▶ The completeness and functionality of field supplied electrical controls and components must be verified by the heating contractor. These include low water cut-offs, flow switches (if used), staging controls, pumps, motorized valves, air vents, thermostats, etc.

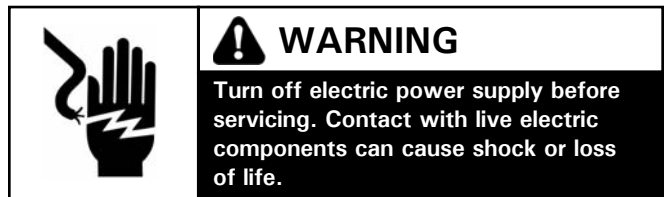

For installations on the Commonwealth of Massachusetts, the following modifications to NFPA-54 chapter 10 apply:

Excerpt from 248 CMR 5-08:

- 2(a) For all side-wall horizontally vented gas fueled equipment installed in every dwelling, building or structure used in whole or in part for residential purposes, including those owned or operated by the Commonwealth and where the side-wall exhaust vent termination is less than (7) feet above finished grade in the area of the venting, including but not limited to decks and porches, the following requirements shall be satisfied:
 - 1. INSTALLATION OF CARBON MONOXIDE DETECTORS. At the time of installation of the side-wall horizontal vented gas fueled equipment, the installing plumber or gas fitter shall observe that a hard wired carbon monoxide detector with an alarm and battery back-up is installed on the floor level where the gas equipment is to be installed. In addition, the installing plumber or gas fitter shall observe that a battery operated or hard wired carbon monoxide detector with an alarm is installed on each additional level of the dwelling, building or structure served by the side-wall horizontal vented gas fueled equipment. It shall be the responsibility of the property owner to secure the services of qualified licensed professional for the installation of hard-wired carbon monoxide detectors.
 - a. In the event that the side-wall horizontally vented gas fueled equipment is installed in a crawl space or an attic, the hard-wired carbon monoxide detector with alarm and battery back-up may be installed on the next adjacent floor level.
 - b. In the event that the requirements of this subdivision can not be met at the time of completion of installation, the owner shall have a period of thirty (30) days to comply with the above requirements; provided, however, that during said thirty (30) day period, a battery operated carbon monoxide detector with an alarm shall be installed.

Important Regulatory and Installation Requirements *(continued)*

- 2. APPROVED CARBON MONOXIDE DETECTORS. Each carbon monoxide detector as required in accordance with the above provisions shall comply with NFPA 720 and be ANSI/UL 2034 listed and IAS certified.
- 3. SIGNAGE. A metal or plastic identification plate shall be permanently mounted to the exterior of the building at a minimum height of eight (8) feet above grade directly in line with the exhaust vent terminal for the horizontally vented gas fueled heating appliance or equipment. The sign shall read, in print size no less than one-half (1/2) inch in size, "GAS VENT DIRECTLY BELOW. KEEP CLEAR OF ALL OBSTRUCTIONS".
- 4. INSPECTION. The state or local gas inspector of the side-wall horizontally vented gas fueled equipment shall not approve the installation unless, upon inspection, the inspector observes carbon monoxide detectors and signage installed in accordance with the provisions of 248 CMR 5.08(2)(a) 1 through 4.

(b) EXEMPTIONS: The following equipment is exempt from 248 CMR 5.08(2)(a) 1 through 4:

- 1. The equipment listed in Chapter 10 entitled "Equipment Not Required To Be Vented" in the most current edition of NFPA 54 as adopted by the Board; and
- 2. Product Approved side-wall horizontally vented gas fueled equipment installed in a room or structure separate from the dwelling, building or structure used in whole or in part for residential purposes.

About these Installation Instructions



Take note of all symbols and notations intended to draw attention to potential hazards or important product information.



WARNING

Warnings draw your attention to the presence of potential hazards or important product information.

- ▶ Indicates an imminently hazardous situation which, if not avoided, could result in death, serious injury or substantial product/property damage.



CAUTION

Cautions draw your attention to the presence of potential hazards or important product information.

- ▶ Indicates an imminently hazardous situation which, if not avoided, may result in minor injury or product / property damage.

IMPORTANT

- ▶ Helpful hints for installation, operation or maintenance which pertain to the product.



- ▶ This symbol indicates to note additional information



- ▶ This symbol indicates that other instructions must be referenced.

General Venting Information

Installation steps (outline)



See Installation Instructions supplied with the boiler.



WARNING

Ensure that the entire venting system is protected from physical damages. A damaged venting system may cause unsafe conditions.

IMPORTANT

Boiler operation in marine environments (damp, salty coastal areas):

The service life of the boiler's exposed metallic surfaces, such as the casing and fan housing, is directly influenced by proximity to damp and salty marine environments. In such areas, higher concentration levels of chlorides from sea spray, coupled with relative humidity, can lead to degradation of the exposed metallic surfaces mentioned above. Therefore, it is imperative that boilers installed in such environments not be installed using direct vent systems which draw outdoor air for combustion. Such boilers must be installed using room air dependent vent systems; i.e. using room air for combustion. The indoor air will have a much lower relative humidity and, hence, the corrosion will be minimized.

- Route vent pipe as directly as possible and with as few bends as possible to the boiler.
- Check proper location of gaskets in rigid PP pipe collars. (Only use supplied parts with the polypropylene venting system.) Apply water to lubricate the joint ends of the vent pipe collar and if used, the air intake pipe collar.
- Slide pipes into each other with a gentle twisting motion.
- Condensate must drain from the flue pipe to the boiler. Ensure a suitable gradient of at least 3° [approx. 2 in. per 3.3 ft. (50 mm per 1 m)].
- Use a hacksaw or sheet metal snips (for stainless steel) to cut pipes to length (if necessary). Use a file to smooth rough edges. Pipe must be round and not bent into an oval shape.

IMPORTANT

When cutting pipes to length, debur and clean pipes.

- For stainless steel and PP venting systems:
In conjunction with these instructions, follow the installation instructions supplied by the special venting manufacturer.

Combustion air intake, flex hose and adaptor must be installed. If using room air-independent venting system, connect the air intake pipe (from outdoors) to the adaptor provided. If room air-dependent venting system is used, the air is drawn into the burner inlet through adaptor and flexible pipe.

Recommended venting practice

When installing a venting system the following recommended venting practices apply:

- Keep length and number of 90° elbows to a minimum.
- Try not to use back-to-back 90° elbows.
- Use 45° elbows where possible to minimize the number of 90° elbows in case redirection of flue gas is required.
- The special vent system shall not be routed into, through, or within any other vent such as an existing masonry or factory-built chimney.

Exception:

A masonry chimney flue may be used to route the venting system only if no other appliance is vented in the same flue.

General Venting Information *(continued)***Approved venting materials**

Part	Material	Certified to Standards	Applicability
Exhaust pipe and fittings	Stainless steel	UL1738 "Venting systems for gas-burning appliances, Categories II, III, IV"	U.S.A./Canada
		ULC S636 "Standard for Type BH gas venting systems"	
	PP Polypropelene	UL1738 "Venting systems for gas-burning appliances, Categories II, III, IV"	
		ULC S636 "Standard for Type BH gas venting systems" Class IIC 110° C	
Combustion air intake pipe and fitting	Stainless steel	n.a.	
	PVC-DWV Schedule 40	ANSI/ASTM D2661 CSA B181.1 ULC S102.2 ANSI/ASTM D2665, D1785 CSA B137.3, B181.2 ANSI/ASTM F441	
	CPVC Schedule 40	ANSI/ASTM D2661 CSA B181.1 ULC S102.2 ANSI/ASTM D2665, D1785 CSA B137.3, B181.2 ANSI/ASTM F441	
	ABS-DWV Schedule 40	ANSI/ASTM D2661 CSA B181.1 ULC S102.2 ANSI/ASTM D2665, D1785 CSA B137.3, B181.2 ANSI/ASTM F441	
	PP Polypropelene	UL1738 "Venting systems for gas-burning appliances, Categories II, III, IV"	
ULC S636 "Standard for Type BH gas venting systems" Class IIC 110° C			
Pipe cement, primer (for combustion air intake pipe)	PVC	ANSI/ASTM D2564 CSA B137.3	
	CPVC	ANSI/ASTM F493 CSA B137.6	
	ABS	ANSI/ASTM D2235 CSA B181.1/B182.1	

Note: Venting systems may combine two different approved venting materials, provided that all venting materials and all required transition adaptors are supplied by one venting manufacturer. Always use latest edition of applicable standard.

**CAUTION**

On the job site, ensure that non-listed combustion air pipe materials are not inadvertently used instead of listed vent pipe material.

**CAUTION**

Do not use cellular (foam) core pipe material to vent this Vitocrossal boiler.

General Venting Information *(continued)*

Flashing and storm collar installation

Flashings and storm collars are field supplied. Flashings and storm collars suitable for Type B vent materials (or better) may be used.

To obtain flashings and storm collars, please contact your local vent material supplier. Follow the installation instructions supplied by the special venting manufacturer.

Follow local codes to properly isolate the exhaust vent pipe when passing through floors, ceiling and roof.

Always check the marking on the pipe to make sure you are using the correct material.

Contact one of the suppliers (see listing on right) to order the vent system.

Prior to installation, check that the correct single-wall vent parts were ordered and supplied.

Exhaust vent/air intake connection to boiler

The vent connection to the Vitocrossal boiler must be made with the starter stainless steel adaptor when using stainless steel (supplied by others).

Combustion air intake, flex hose and adaptor must be installed. If using room air-independent venting system, connect the air intake pipe (from outdoors) to the adaptor provided. If room air-dependent venting system is used, the air is drawn into the burner inlet through adaptor and flexible pipe.

IMPORTANT

For exhaust vent pipe material:
Do not use any other vent material.

 **WARNING**

The use of vent material other than listed UL/ULC stainless steel and PPs positive pressure vent pipe and fittings can cause property damage, severe personal injury and/or loss of life.

Vent System Suppliers

Use special venting system (UL/ULC listed for Category IV) for exhaust vent material of the Vitocrossal boilers (contact one of the venting suppliers).

<p>M&G / Duravent Tel. 800-835-4429 Tel. 518-649-9700 Fax: 518-463-5271 Email: sales@duravent.com Web: www.duravent.com</p>	<p>ICC - Industrial Chimney Co. 400 J-F Kennedy, St-Jerome, Quebec Canada, J7Y 4B7 Tel. 514-565-6336 Fax: 514-565-6519 Email: sales@ICC-RSF.com</p>
<p>Selkirk Canada Corporation 375 Green Road Stoney Creek, ON L8E 4A5 Tel.: (905) 662-6600 Fax: (905) 662-5352 (US) 1-800-992-8368 (Canada) 1-888-735-5475 Email: info@selkirkcorp.com Web: www.selkirkchimney.com</p>	<p>Novaflex 1-20 East Pearce St., Richmond Hill, Ontario, Canada, L4B 1B7 Tel. 905-731-9411 Email: sales@flexmaster.com</p>
<p>Security Chimneys International Ltd. 2125 Rue Monterey, Laval, Quebec H7L 3T6 Tel. 450-973-9999 (US) 1-800-361-4909 (Canada) 1-800-667-3387 Fax: 450-973-2222 Email: infoeng@securitychimneys.com Web: www.securitychimneys.com</p>	<p>Energex Inc. (formerly Exhausto) Tel: 770-587-3238 Fax: 770-587-4731 (800) 225-2923 Email: info@exhausto.com Web: www.vpstack.com</p>
<p>Wesmech Technical Sales 50 Ronson Drive, Suite 160 Toronto, ON M9W 1B3 Tel.: (416) 251-8990 Fax: (416) 251-8900 1-800-613-3789 Email: info@wesmechtech.com Web: www.wesmechtech.com</p>	<p>Van-Packer Co. Inc. 302 Mill Street PO Box 307 Buda, IL 61314 Tel.: (309) 895-2311 Fax: (309) 895-3891 1-888-877-8225 Email: vpstack@theramp.net Web: www.vpstack.com</p>
<p>Centrotherm InnoFlue Eco Systems. L.L.C. Tel.: (877) 434-3432 Fax.: (518) 618-3166 Email: info@centrotherm.us.com Web: www.centrotherm.us.com</p>	

Note: For SS venting system order transition adaptors from the above mentioned suppliers.

Requirement for UL/ULC Listed Rigid SS/PP(s) Vent Pipe Material

Requirements for PP and stainless steel



See Installation Instructions supplied with the boiler.

The venting system must be installed by a licensed professional heating contractor familiar with the operation and maintenance of heating appliances and venting. Before installing, ensure that the complete installation literature has been read. Failure to follow proper installation procedures as stated in these instructions, including vent pitch and proper appliance connections, may violate local, provincial/state, or national codes and cause unsafe conditions which may lead to severe property damage or personal injury.

The venting system must be installed in accordance with local building code requirements as well as national codes. For installations in Canada use CAN/CSA-B149.1 Natural Gas Installation Code or CAN/CSA-B149.2

Propane Installation Code as applicable; in the U.S. use the National Fuel Gas Code ANSI Z223.1 or NFPA Standard 54. Always use latest edition of applicable standard.

To ensure safe operation of the appliance, Viessmann recommends that the system be inspected once a year by a qualified service technician.

Every venting system must be planned and installed for optimum performance and safety. These Installation Instructions are designed to help you determine venting requirements and limitations with respect to installation. Please read and follow these instructions carefully.

It is the responsibility of the installer to contact local building and fire officials concerning any installation restrictions and/or inspection requirements that may apply. Permits may be required before commencement of the installation.

The air intake termination (if installed on a side wall) should be located on a wall that is least affected by prevailing winds. High winds may affect boiler operation. If wind is a problem, steps must be taken to shield the air intake termination from high winds, such as building a fence or planting shrubs. Ensure that the total equivalent vent length is not exceeded.

Because of its sealed combustion chamber, the Vitocrossal 200 gas-fired condensing boiler is suitable for operation with balanced flue (when using air intake system).

Use only material listed in table on page 7, entitled "Approved venting materials".

This PP vent system is constructed from flame-retardant plastic [polypropylene rated for a maximum temperature of 230° F (110° C)].

The PP venting system components must be listed to ULC S636 / UL-1738 (contact one of the venting suppliers see page 8).

DO NOT mix pipe, fittings, or joining methods from different vent system manufacturers.

The vent length requirements stated in this manual on page 12 must be observed.

If using flexible air intake pipe, reduce the maximum equivalent length allowed by 25%.

Vent Requirements

Combustion air supply, room air dependent application only

This boiler requires fresh air for safe operation and must be installed in a mechanical room where there are provisions for adequate combustion and ventilation air. There are provisions available on the Vitocrossal boiler to interlock it with an external combustion air blower.

Provisions for combustion and ventilation air must be made in accordance with CAN/CSA-B149.1 or .2 Natural Gas Installation Codes (for installations in Canada) or in accordance with sections for Combustion and Ventilation Air, of the National Fuel Gas Code, ANSI Z223.1 or applicable provisions of local codes (for installations in the U.S.A.)

Always use latest edition of applicable standard.

Follow local codes to properly isolate the vent pipe when passing through floors, ceilings and roof.

Whenever possible, install boiler near an outside wall so that it is easy to duct fresh air directly to the boiler area. Refer to national codes for duct sizing. Round ducts may be used.

The boiler must be vented and supplied with combustion air and exhaust vents as described in this section. Ensure the vent and combustion air supply comply with these instructions.



WARNING

Failure to provide an adequate supply of fresh combustion air can cause poisonous flue gases to enter living space, which can cause severe personal injury or loss of life.

The boiler location should never be under negative pressure. Exhaust fans, attic fans, or dryer fans may cause air to be exhausted at a rate higher than the air can enter the structure for safe combustion. Corrective action must be taken to ensure enough air is available. Never cover the boiler or store debris or other materials near the boiler, or in any way block the flow of adequate fresh combustion air to the boiler.

If boiler is installed in a confined space (a space with a volume of less than 50 cubic feet per 1000 Btu/h of gas input for all fuel burning equipment) or building layout is unusually tight, adequate air for combustion must be provided by two openings: one located about 6 in. below the ceiling, the other about 6 in. above the floor. When communicating directly with the outside, each opening must have a minimum free area of one square inch per 2000 Btu/h of gas input. When all combustion air is provided by openings in doors, etc. to adjoining spaces having adequate infiltration, each opening must have a minimum free area of one square inch per 1000 Btu/h of gas input, but not less than 100 in².

You must know the free area of louvers used to cover up the combustion and ventilation openings in closet installations. If you do not know the free area, assume 20% for wood louvers and 60-75% free area for metal louvers. When using louvers, the openings have to be made larger.

For example, a free 14 in. x 6 in. (356 mm x 152 mm) opening becomes a 14 in. x 10 in. (356 mm x 254 mm) opening for a grill containing metal louvers.



CAUTION

Do not store chemicals containing chlorine or other corrosive materials near the boiler, such as bleach, cleaning solvents, detergents, acids, hair spray, spray cans, paint thinners, paint, water softener salt, perchloroethylene, or carbon tetra chloride.

Clearances

Note: Only a maximum of 4 boilers can be connected to a common vent system.

General

- Only the Vitocrossal 200 boilers CM2 can be connected to a common vent (header).
- The Vitocrossal 200 boilers connected to the common vent must all be of the same size.
- Each boiler must have a certified Viessmann supplied flue vent damper installed.
- Flue vent damper opens on call for heat and closes on termination of heat through the Viessmann burner control logic.
- A common combustion air header may be used
- Each boiler must have a separate air intake for combustion air, which can be connected to a common combustion air header.

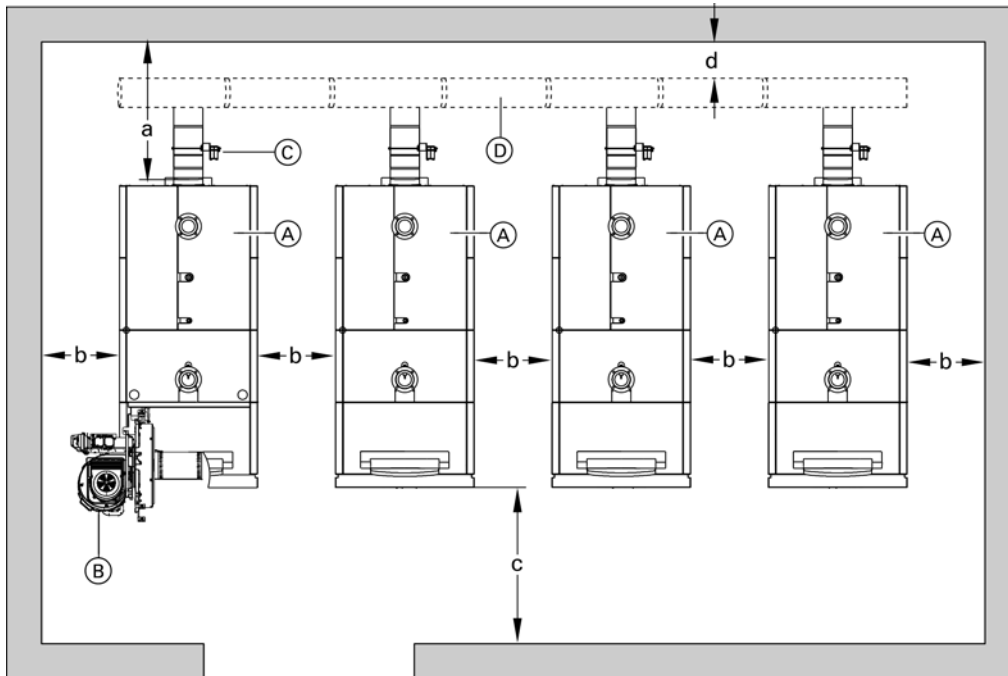

Legend

- Ⓐ Boiler
- Ⓑ Burner
- Ⓒ Flue vent damper
- Ⓓ Flue gas common venting system

Clearance Dimensions

a	35 in. (890 mm)
b	20 in. (500 mm)
c	40 in. (1000 mm)
d	Minimum clearance as per the vent manufacturer

Dimensions

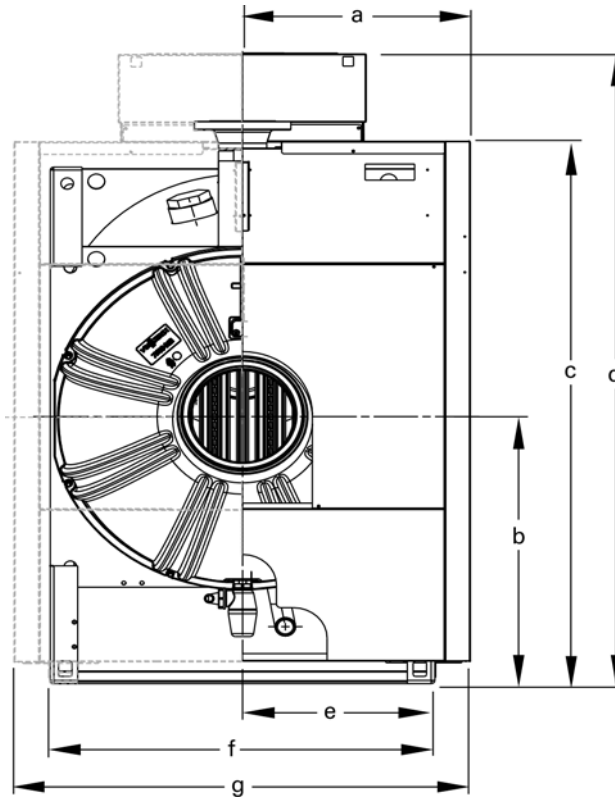

Boiler Dimensions

	CM2-186, -246, -311 in. (mm)	CM2-400 in. (mm)	CM2-500 in. (mm)	CM2-620/620 TX in. (mm)
a	18¼ (465)	21¼ (539)	21¼ (539)	22¼ (564)
b	22 (558)	27 ⁷ / ₈ (708)	27 ⁷ / ₈ (708)	29 (736)
c	56½ (1438)	56¼ (1428)	56¼ (1428)	59½ (1511)
d	66 (1676)	65 ⁵ / ₈ (1666)	65 ⁵ / ₈ (1666)	68¾ (1748)
e	15 (380)	17 ⁷ / ₈ (455)	17 ⁷ / ₈ (455)	18 ⁷ / ₈ (480)
f	30 (760)	35¾ (910)	35¾ (910)	37¾ (960)
g	36½ (930)	42 ³ / ₈ (1078)	42 ³ / ₈ (1078)	44 ³ / ₈ (1128)

Venting Layout

General

- The common vent (header) diameter and the chimney diameter must be same size.
- Sidewall venting is NOT allowed, only vertical direct vent (room air dependant or independent), positive pressure cat. IV or vertical/chimney can be used when common venting.
- The maximum equivalent length of the venting system must not exceed 198 ft. (60 m).
- Operation of the Vitocrossal 200 CM2 common vent system is dependent on the proper installation and operation of the flue vent damper.
- Available pressure at the flue outlet is 70 pa. (0.28 "w.c.). Pressure available at the outlet of the boiler flue collar can be used to calculate a revised vent system by the vent manufacturer (if needed).
- Only a maximum of 4 boilers can be connected to a common vent system.
- Only a maximum of 4 boilers can be connected to a common combustion air intake header.

IMPORTANT

If the venting layout configurations described in these instructions are changed (e.g. including additional components) it is the responsibility of the venting manufacturer to recalculate the vent diameter. **DO NOT** reduce venting diameters listed.

IMPORTANT

The boiler flue damper or flue collar are not designed to support the weight of the vent system connected to the boiler. Contact the vent manufacturer for proper support. See list of manufacturers on page 8.

Common Header and Chimney Diameters

# of similar boilers	CM2-186 in. (mm)	CM2-246 in. (mm)	CM2-311 in. (mm)	CM2-400 in. (mm)	CM2-500 in. (mm)	CM2-620/620 TX in. (mm)
2	10 (250)	10 (250)	12 (300)	14 (350)	14 (350)	16 (400)
3	12 (300)	12 (300)	14 (350)	16 (400)	18 (450)	20 (500)
4	12 (300)	14 (350)	16 (400)	18 (450)	20 (500)	22 (550)

Boiler Combustion Air Intake Diameter

Model of CM2	Combustion Air Intake \varnothing in. (mm)
186	\varnothing 6 (150)
246	\varnothing 6 (150)
311	\varnothing 6 (150)
400	\varnothing 8 (200)
500	\varnothing 8 (200)
620/620 TX	\varnothing 8 (200)

Note:

When using a common combustion air intake header, free area of the common combustion air intake header is the free area of the combustion air intake diameter times the number of boilers connected to the common combustion air intake header.

Venting Layout *(continued)*

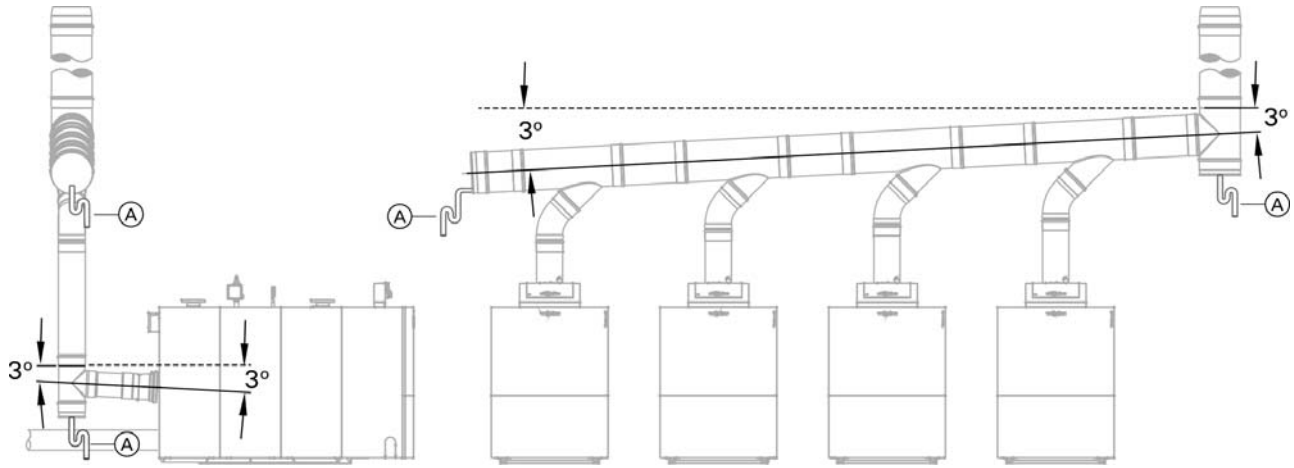

Legend

- Ⓐ Condensate drain piping
- a air intake
- b exhaust vent

IMPORTANT

Condensate must drain from the flue pipe to the boiler. Ensure a suitable gradient of at least 3° [approx. 2 in. per 3.3 ft. (50 mm per 1 m)] on any horizontal venting components.

Note: Maximum equivalent vent length includes the longest of each of the following combined; air intake pipe, flue gas vent (from boiler to common header), common header and chimney.

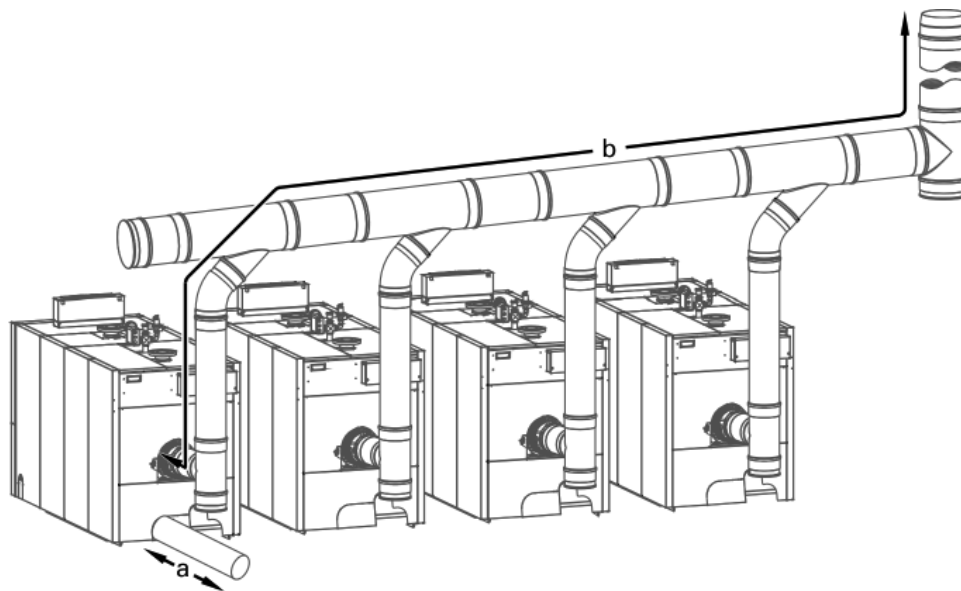

Maximum equivalent vent length
 = a + b
 = max. 198 ft. (60 m)

Removing the Junction Box Cover

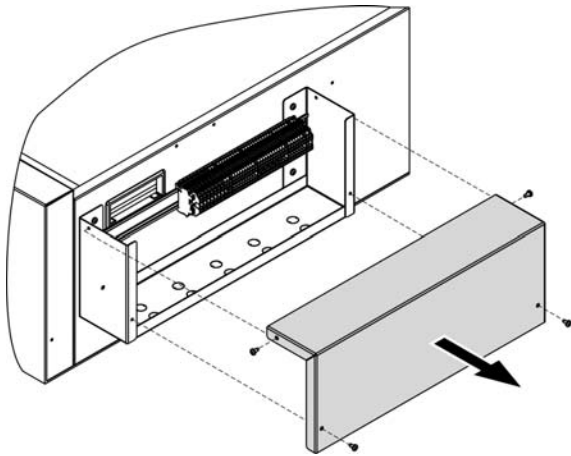

WARNING

Mains voltage can be highly dangerous and cause of loss life. Shut off boiler power supply at main disconnect before proceeding.

1. Remove the four junction box retaining screws and set aside.
2. Remove the junction box cover and set aside.

Removing the Front Panel (CM2-186, -246 and -311)

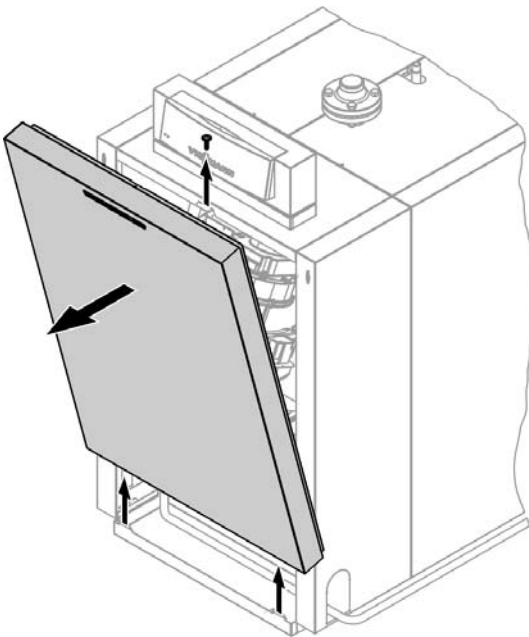

1. Remove top screw then lift door, pull forward and remove.

Removing the Top Front Panel (CM2-400, -500, -620 and -620TX)

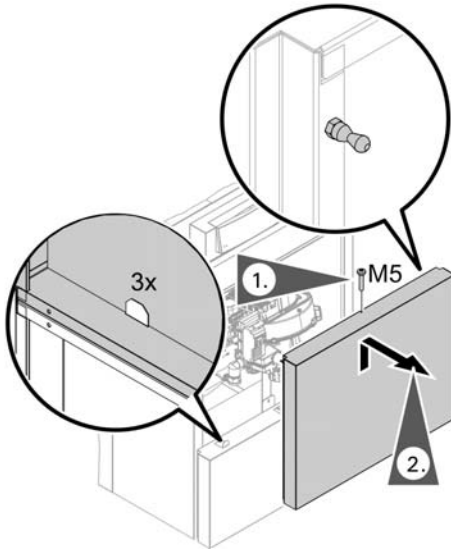

1. Remove the M5 screw and set aside.
2. Pull out the top of the panel and lift.
3. Remove the top front panel and set aside.

Removing the Bottom Front Panel (CM2-400, -500, -620 and -620TX)

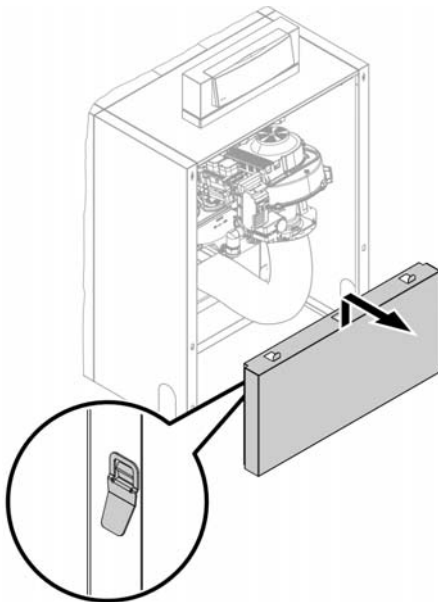

1. Pull out the bottom of the front panel with the clips from the side panel.
2. Remove the bottom front panel and set aside.

Removing the Side Panels

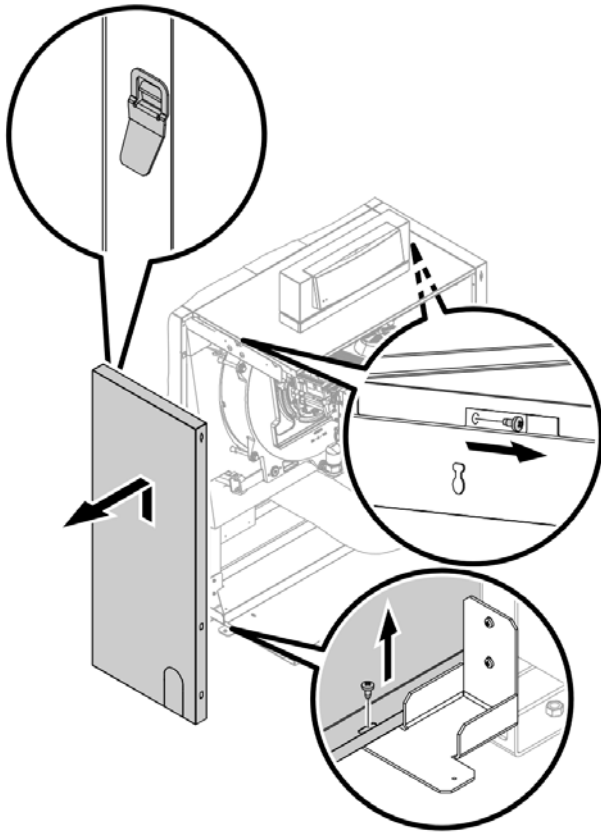

1. Remove the M6 screws (two per panel) one on the top rail and one on the bottom support. Then lift up and remove the panel.

Installing the Flue Vent Damper

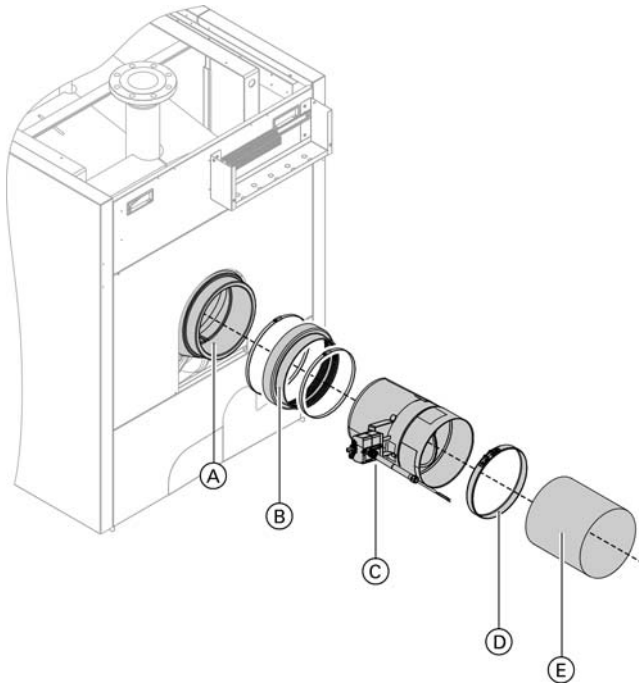

1. Install the flue vent vent coupling (B) to the flue gas collector (A) and secure with the supplied gear clamp.
2. Install flue vent damper (C) into the flue gas vent coupling (B) and secure with the supplied gear clamp.

IMPORTANT

Install the damper with the actuator located on the left or right.

3. Install flue vent damper adaptor collar (D) around the flue vent damper (C) and tighten.

IMPORTANT

Ensure the gasket is properly seated prior to tightening.

4. Install venting by inserting the venting into the flue vent damper adaptor collar (D) and ensure the venting is fully seated.

IMPORTANT

DO NOT install the flue vent damper on any vertical venting components. Install the flue vent damper only as shown.

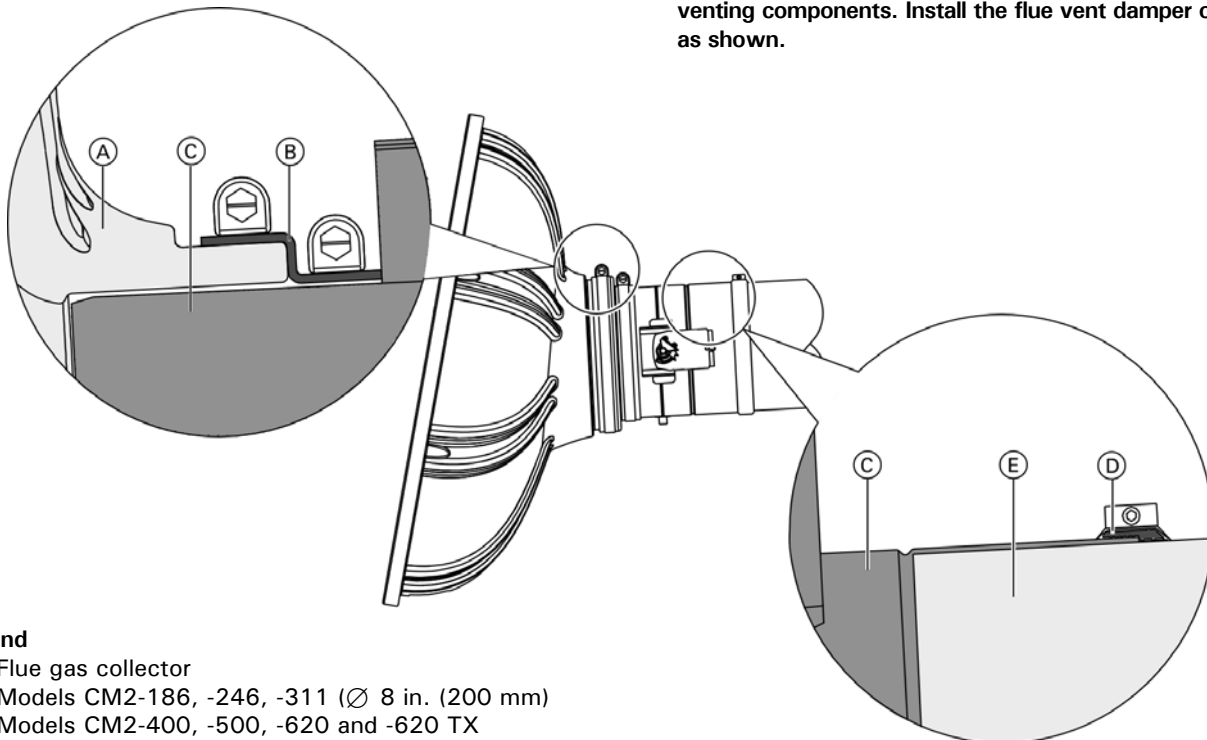

Legend

- (A) Flue gas collector
Models CM2-186, -246, -311 (Ø 8 in. (200 mm))
Models CM2-400, -500, -620 and -620 TX
(Ø 10 in. (250 mm))
- (B) Flue gas vent coupling
- (C) Flue vent damper
- (D) Flue vent damper adaptor collar
- (E) Approved venting material (field supplied)

Removing the Top Panels - Vitotronic 300 GW5B

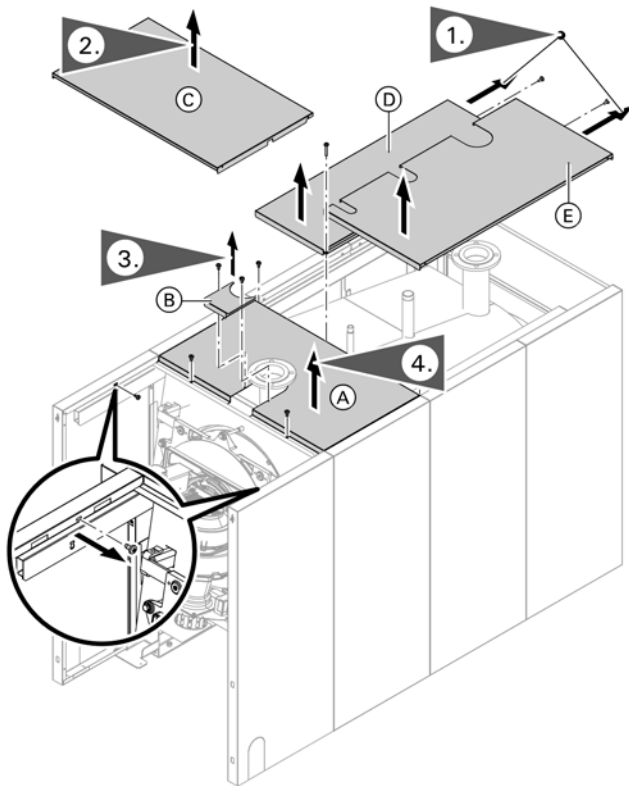

Note: These instructions apply only to the Vitocrossal 200 boilers equipped with a Vitotronic 300 GW5B control.

1. Remove the RH rear top panel (E) and LH rear top panel (D) with one 4.8 mm screw each (set aside).
2. Remove front top panel (C) with two M6 screws (set aside).
3. Remove cover (B) from the tie-bar with two 4.8 mm screws (set aside).
4. Remove the central top panel (A) from the tie-bar with two 4.8 mm screws and from the back of the panel with one 4.8 mm screw each (set aside).

Routing the Flue Vent Damper Cabling - Vitotronic 300 GW5B

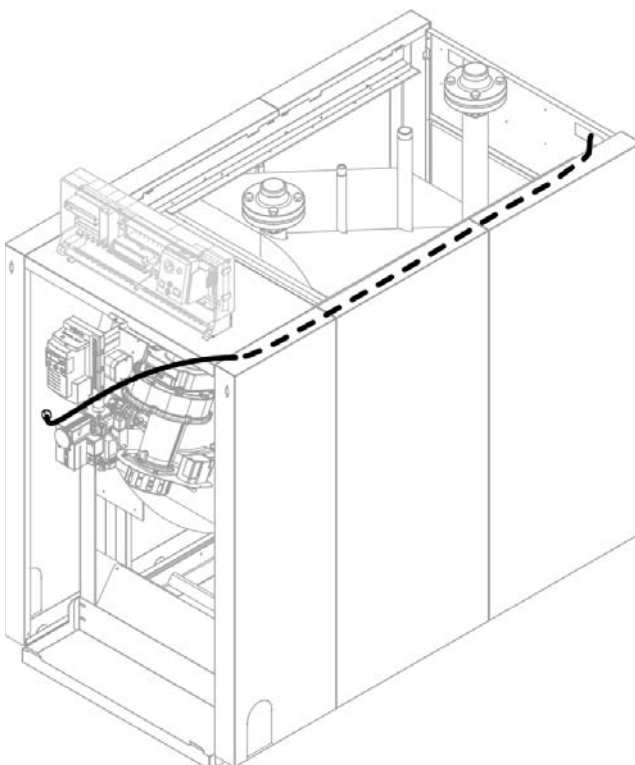

Note: These instructions apply only to the Vitocrossal 200 boilers equipped with a Vitotronic 300 GW5B control.

CAUTION

Melting insulation can lead to equipment damage. Electronic wires must not come into contact with each other or hot components.

1. Route the 53 cable through the boiler cable tray back to the junction box.

Connecting the Flue Vent Damper Cable to the Burner Control - Vitotronic 300 GW5B

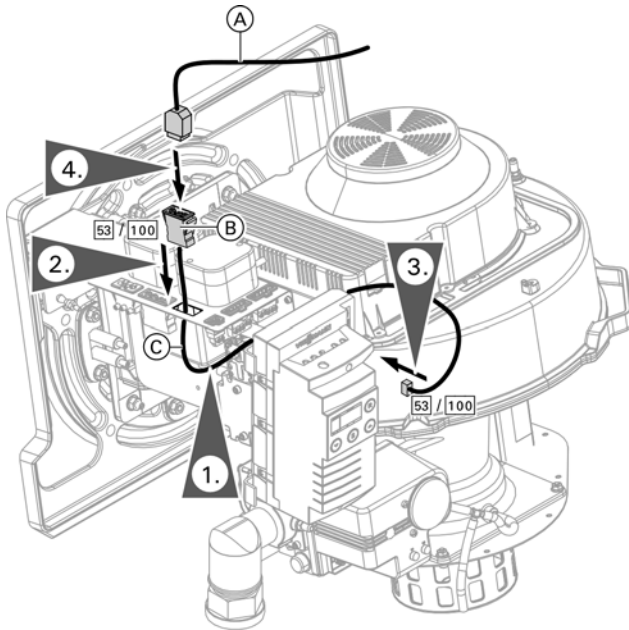

Note: These instructions apply only to the Vitocrossal 200 boilers equipped with a Vitotronic 300 GW5B control.

IMPORTANT

Some models of the CM2 cylinder burner will come with cable C already preinstalled from the factory. Verify if this cable is preinstalled or included with the vent damper. If preinstalled skip steps 1 to 3.

1. Route cable C (included with flue vent damper) through the cutout in the burner bracket (cutout is labelled 53).
2. Lock plug B into place in the burner bracket
3. Route cable C to the front of the burner control and plug into the burner base (labelled 53 / 100).
4. Connect the plug of cable A into plug B.

Legend

- A Cable 53
- B Large plug of cable C
- C Cable 53 / 100 (included with flue vent damper)

Installing the Top Panels - Vitotronic 300 GW5B

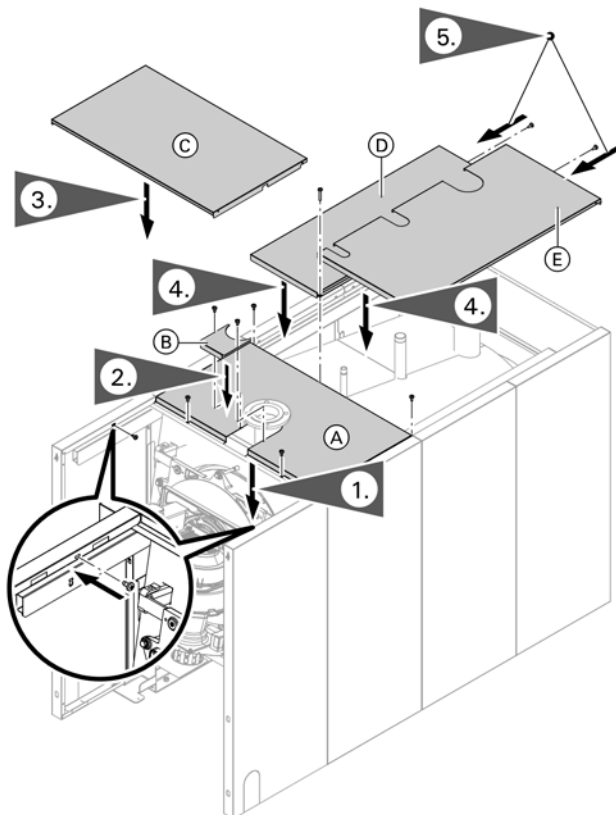

Note: These instructions apply only to the Vitocrossal 200 boilers equipped with a Vitotronic 300 GW5B control.

1. Secure the front edge of central top panel A to the tie-bar with two 4.8 mm screws and secure the back of the panel to the LH and RH top rails with one 4.8 mm screw each.
2. Secure cover B to the tie-bar with two 4.8 mm screws.
3. Secure front top panel C to the front side panels with two M6 screws.
4. Position LH rear top panel D. Then position RH rear top panel E. Where they overlap in the middle, secure both rear top panels to the central top panel with one 4.8 mm x 38 mm screw.
5. Secure RH rear top panel E and LH rear top panel D to the back panel with one 4.8 mm screw each.

Installing the Flue Vent Damper Wiring to the Junction Box - Vitotronic 300 GW5B

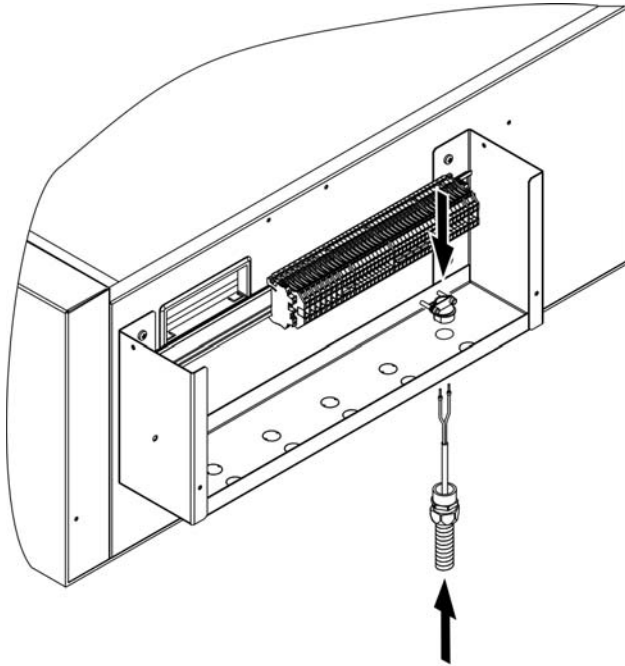

IMPORTANT

These instructions apply only to the GW5B part # 7533564 in conjunction with junction box part # 7506693 (for CM2-186, -246, -311) and junction box part #7201084 (for CM2-400, -500, -620, -620TX).

1. Select an available cable opening in the junction box and remove the knockout.
2. Insert the cable restraint into the knockout then, feed in the flue vent damper actuator cable.
3. Secure the armor cable in place with the supplied cable restraint.
4. Tighten the cable restraint to secure the cable.

Connecting the Flue Vent Damper Cable to the Junction Box - Vitotronic 300 GW5B

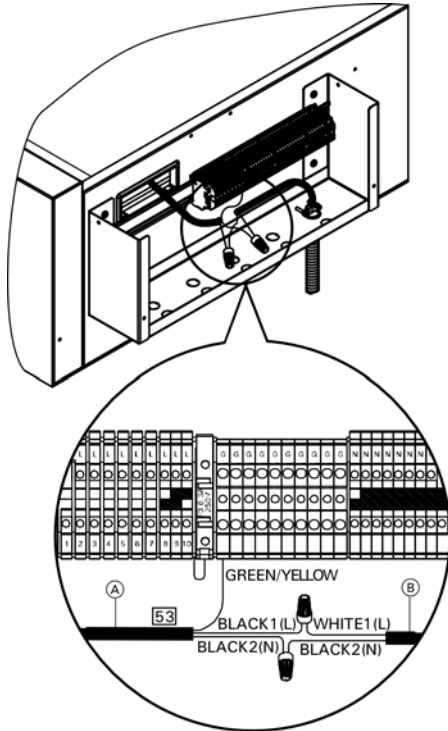

IMPORTANT

These instructions apply only to the GW5B part # 7533564 in conjunction with junction box part # 7506693 (for CM2-186, -246, -311) and junction box part #7201084 (for CM2-400, -500, -620, -620TX).

1. Connect white (L) wire labelled 1 from the flue vent damper cable to the black (L) wire labelled 1 of the **53** cable (with supplied marrett).
2. Connect black (N) wire labelled 2 from the flue vent damper cable to black (N) wire labelled 2 of the **53** cable (with supplied marrett).
3. Install the green/yellow wire to an open grounding terminal of the DIN rail.

Legend

- (A) Cable **53**
- (B) Flue vent damper cable

Installing the Flue Vent Damper Wiring to the Junction Box - Vitotronic 300 GW5B

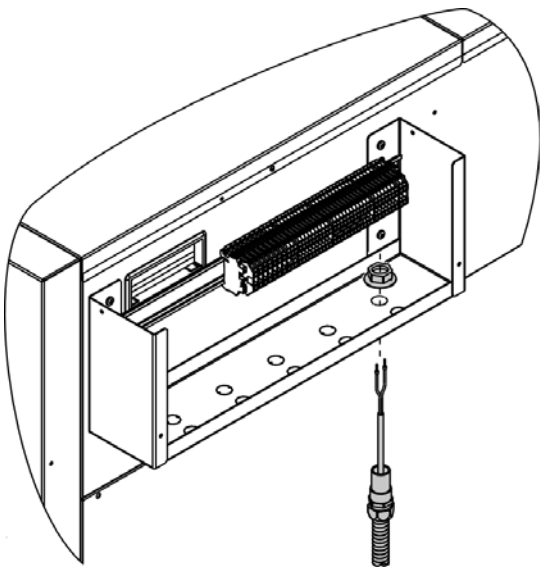

IMPORTANT

These instructions apply only to the GW5B part # 7537696 in conjunction with junction box part # 7535698 (for CM2-186, -246, -311) and junction box part # 7535902 (for CM2-400, -500, -620, -620TX).

1. Select an available cable opening in the junction box and remove the knockout.
2. Insert the flue vent damper actuator cable into the junction box opening.
3. Secure the armor cable in place with the supplied locking nut.

Connecting the Flue Vent Damper Cable to the Junction Box - Vitotronic 300 GW5B

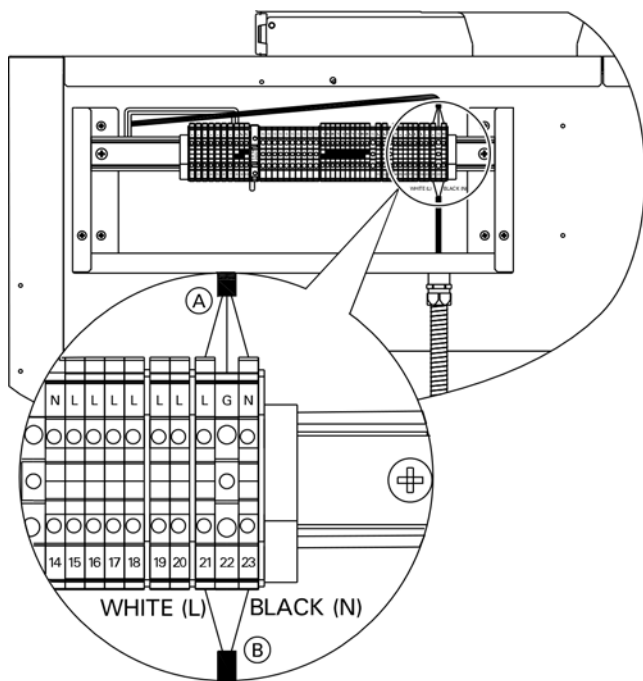

IMPORTANT

These instructions apply only to the GW5B part # 7537696 in conjunction with junction box part # 7535698 (for CM2-186, -246, -311) and junction box part # 7535902 (for CM2-400, -500, -620, -620TX).

1. Connect the flue vent damper cable, white (L) wire to terminal 21 and the black (N) wire to terminal 23 of the junction box DIN rail.

Installing the Flue Vent Damper Cable to the Junction Box - Vitotronic 300 GW6B

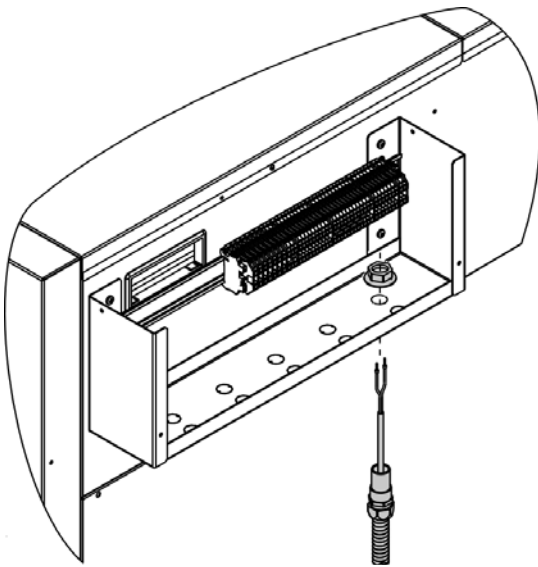

1. Select an available cable opening in the junction box and remove the knockout.
2. Insert the flue vent damper actuator cable into the junction box opening.
3. Secure the armor cable in place with the supplied locking nut.

Connecting the Flue Vent Damper Cable to the Junction Box - Vitotronic 300 GW6B

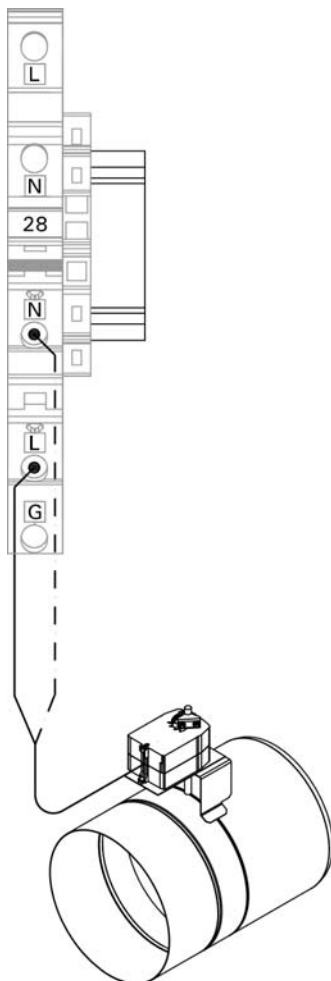

1. Connect the flue vent damper cable, white (L) wire to terminal 28 (L) and the black (N) wire to terminal 28 (N) of the junction box DIN rail.

Burner Control Unit

The display comprises four elements of seven segments each. Four keys enable adjustments to be made at the different operating levels.

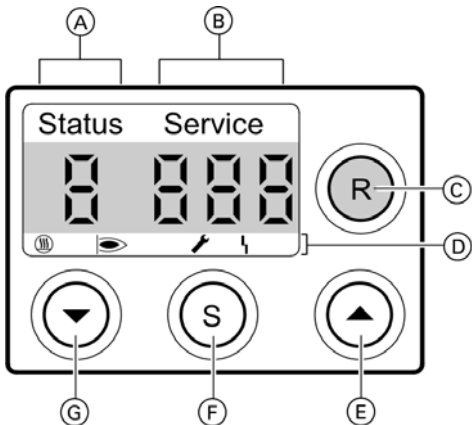

Legend

- (A) Status display
- (B) Service display
- (C) Reset button
- (D) LEDs, from left: heat demand, flame, maintenance and fault.
- (F) Selection key
- (E)/(G) Cursor keys

Display and programming unit

A display and programming unit is integrated into the burner control unit. The display indicates the relevant operating conditions, the service and parameter conditions as well as all fault and error messages.

To set the motorized flue damper (flue gas cascade) press the following buttons:

1. **S** longer than 2 seconds.
2. **▲** until "6" is shown under Service.
3. **S** "6" will be displayed under Status and 1 under Service.
4. **▲** until "7" is shown under Service.
5. **S** "7" will be displayed under Status.
6. **▲/▼** for integration of flue damper to "1" will be displayed under Service.
7. **S** to confirm. If applied successfully, "1" will be shown under Service, "0" if it failed.
8. **S** to change to the operating display.

Installing the Junction Box Cover

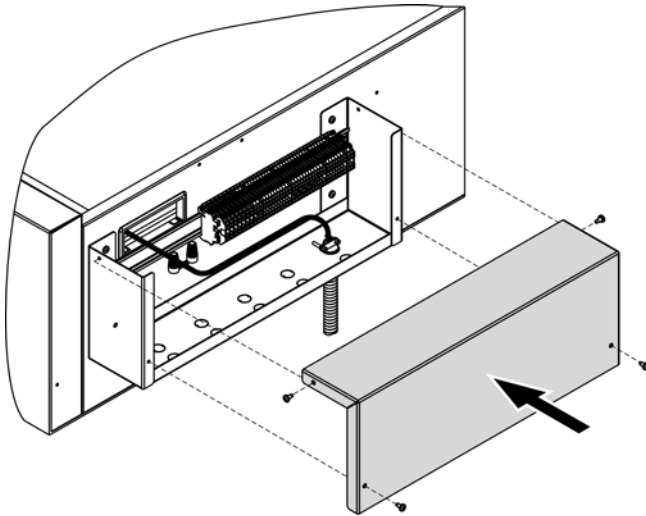

1. Install the junction box cover and secure with the retaining screws.

Installing the Side Panels

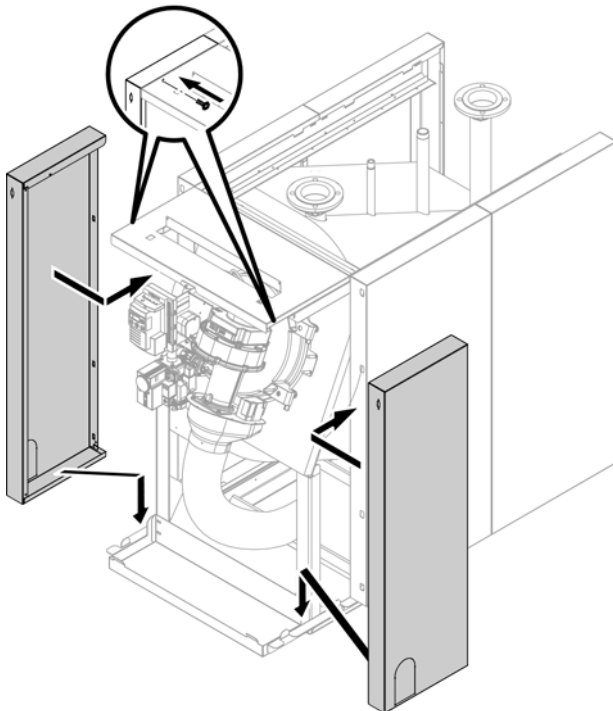

1. Install the side panel into the bottom frame and secure the top with a retaining screw.

Installing the Front Panel (CM2-186, -246 and -311)

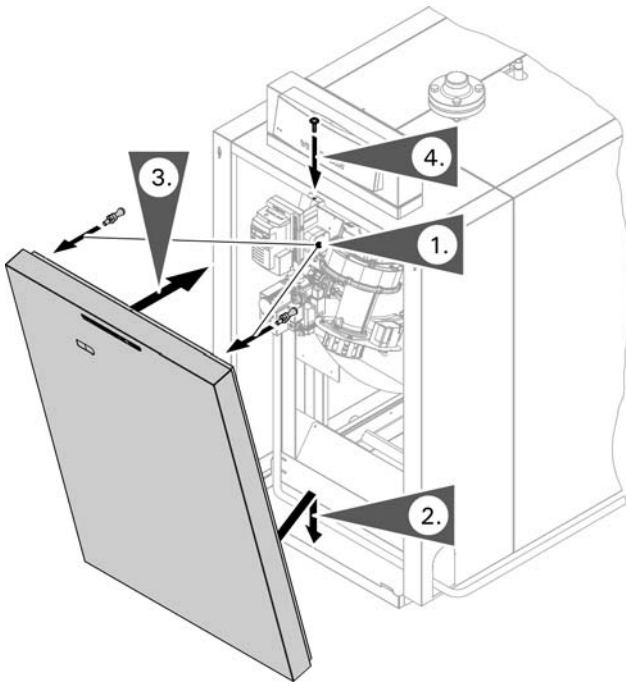

1. Screw profile studs into the threads of the front panel (door).
2. Insert front panel retainers into the notches on the bottom panel.
3. Tilt up the door and snap door into place.
4. Secure door with M5 screw.

Installing the Front Panels (CM2-400, -500, -620 and -620TX)

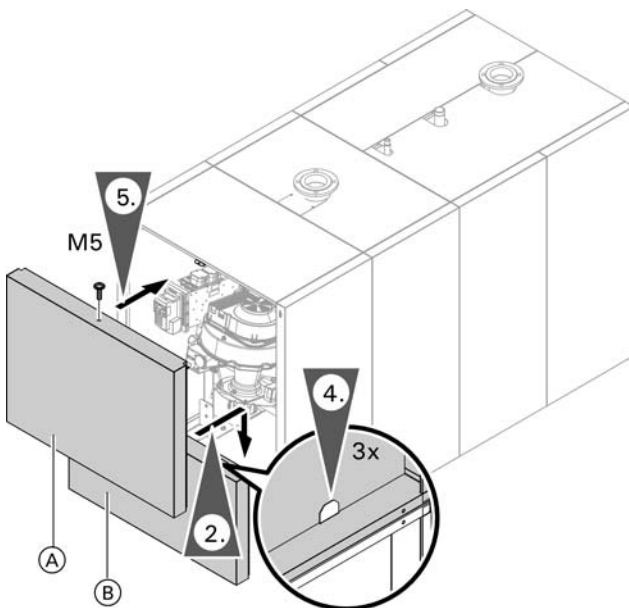

1. Hook bottom front panel (B) into the front side panels.
2. Position top front panel (A) onto bottom front panel (B).
3. Fit top front panel (D) so that the profile studs at the top lock into the side panels. Secure with a M5 screw.

Common Venting Header with Vertical Connections

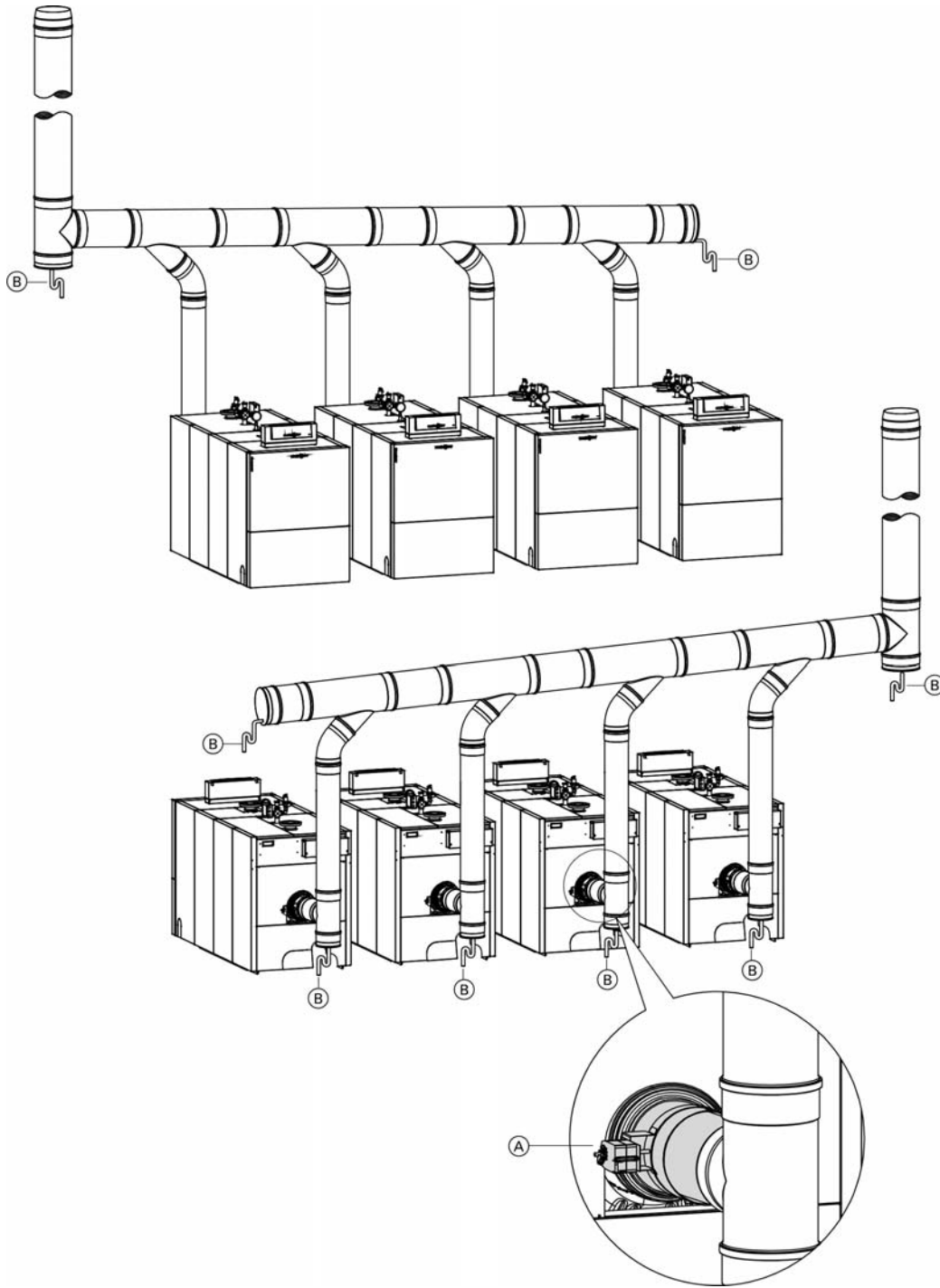

Legend

- (A) Flue vent damper
- (B) Condensate drain piping

Common Venting Header with 45° Connections

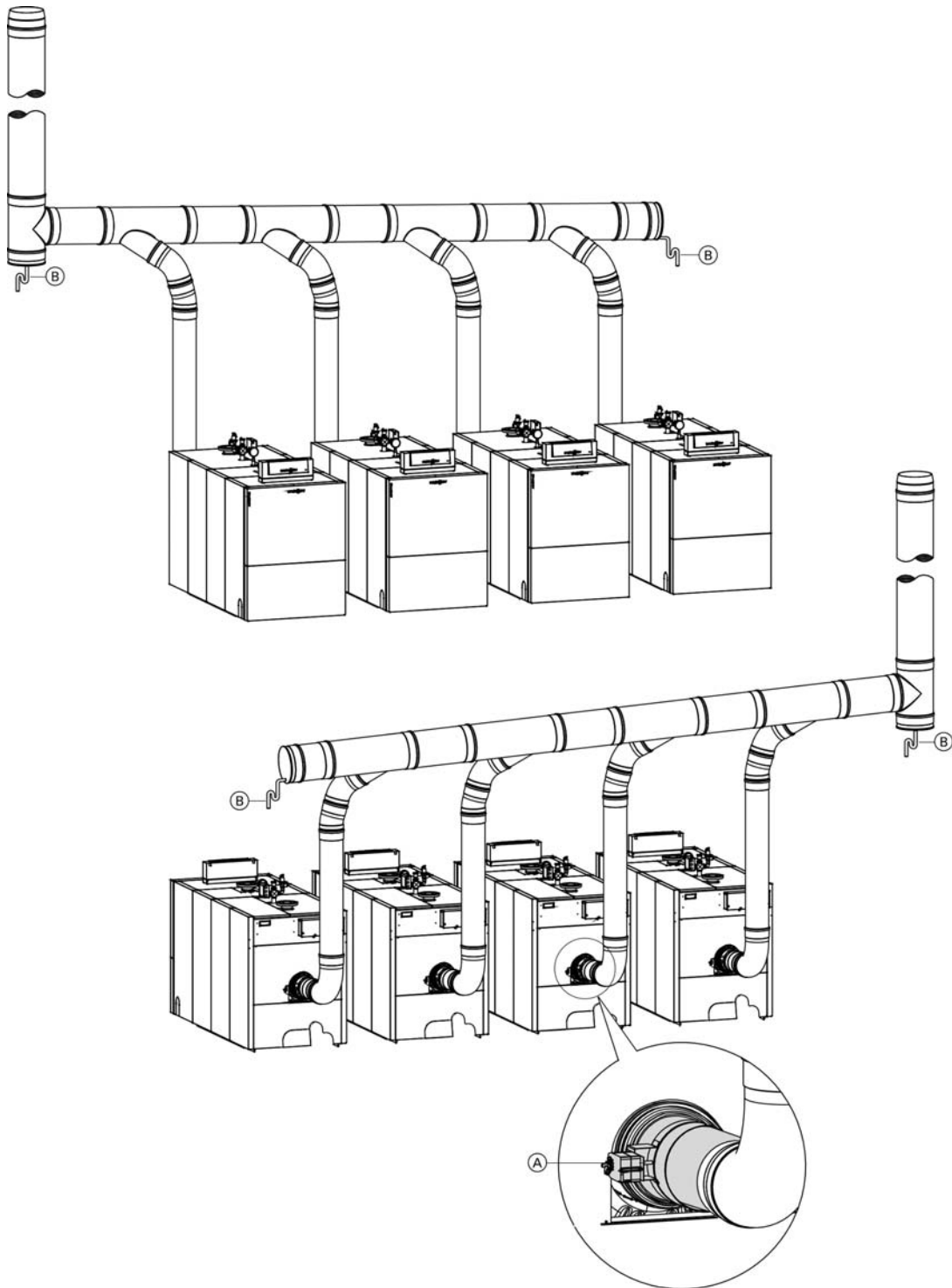

Legend

- (A) Flue vent damper
- (B) Condensate drain piping

Common Venting Header with 90° Connections

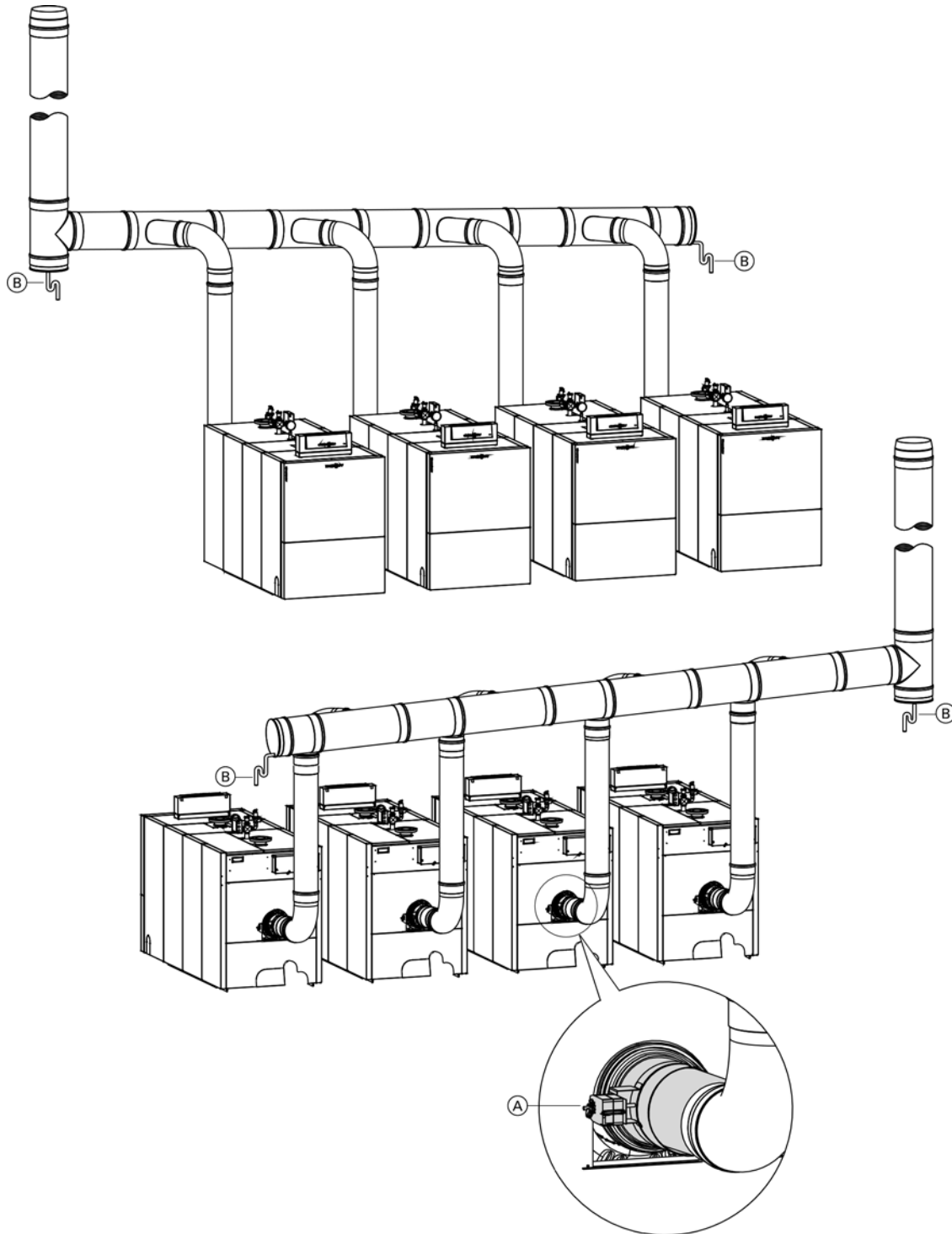

Legend

- (A) Flue vent damper
- (B) Condensate drain piping

Flue Vent Damper

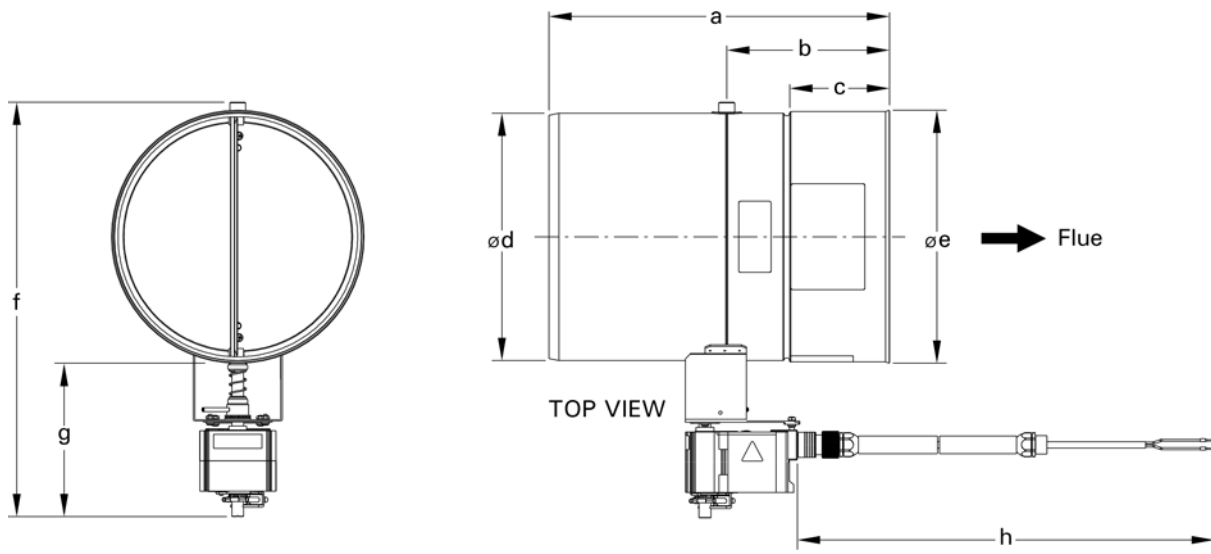

CM2 Models		186, 246 and 311	400, 500, 620 and 620 TX
a	in. (mm)	13 $\frac{5}{8}$ +/- $\frac{3}{16}$ (345 +/- 5)	13 $\frac{5}{8}$ +/- $\frac{3}{16}$ (345 +/- 5)
b	in. (mm)	6 $\frac{1}{2}$ +/- $\frac{1}{8}$ (165 +/- 3)	6 $\frac{1}{2}$ +/- $\frac{1}{8}$ (165 +/- 3)
c	in. (mm)	4 +/- $\frac{1}{8}$ (100 +/- 3)	4 +/- $\frac{1}{8}$ (100 +/- 3)
d (boiler side)	in. (mm)	Ø 7.87 +0/-0.04 (200 +0/-1)	Ø 9.84 +0.00/-0.04 Ø (250 +0/-1)
e (vent side)*	in. (mm)	Ø 7.91 +0/-0.04 (201 +1/-0)	Ø 9.88 +0.04/-0.01 Ø (251 +1.0/-0.0)
f	in. (mm)	14 $\frac{1}{2}$ +/- $\frac{3}{8}$ (369 +/- 10)	16 $\frac{1}{2}$ +/- $\frac{3}{8}$ (419 +/- 10)
g	in. (mm)	6 $\frac{1}{4}$ +/- $\frac{3}{16}$ (185 +/- 5)	6 $\frac{1}{4}$ +/- $\frac{3}{16}$ (185 +/- 5)
h (cable length)	in. (mm)	61 $\frac{3}{4}$ +/- $\frac{5}{8}$ (1570 +/- 16)	61 $\frac{3}{4}$ +/- $\frac{5}{8}$ (1570 +/- 16)

* When using a stainless steel vent system, a flue damper vent adaptor must be designed by the vent manufacturer to connect to the vent damper (contact one of the venting suppliers on page 8). Dimension "d" with tolerances specified can be used.

- Rated voltage 120V ~
- Rated frequency 60 Hz
- Rated current 6VA
- Power consumption 2.5W
- Protection class I
- Permissible ambient temperature
- During operation 32 to 104° F (0 to 40° C)
- During storage and transport -4 to +149° F (-20 to +65° C)

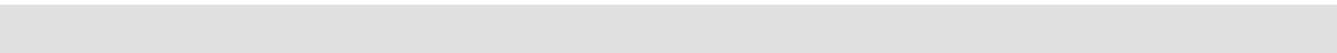



Printed on environmentally friendly
(recycled and recyclable) paper.

Technical information subject to change without notice.

Viessmann Manufacturing Company Inc.
750 McMurray Road
Waterloo, Ontario • N2V 2G5 • Canada
TechInfo Line 1-888-484-8643
1-800-387-7373 • Fax (519) 885-0887
www.viessmann.ca • info@viessmann.ca

Viessmann Manufacturing Company (U.S.) Inc.
45 Access Road
Warwick, Rhode Island • 02886 • USA
TechInfo Line 1-888-484-8643
1-800-288-0667 • Fax (401) 732-0590
www.viessmann-us.com • info@viessmann-us.com