



CITY OF PORTLAND, MAINE
Department of Building Inspections

Aug 29 20 05

Received from Matthew Bean

Location of Work 14 Hill St.

Cost of Construction \$ 2.00.-

Permit Fee \$ 30.00

Building (I1) Plumbing (I5) Electrical (I2) Site Plan (U2)

Other _____

01-54 C 003

Check #: 114

Total Collected \$ 30.-

THIS IS NOT A PERMIT

No work is to be started until PERMIT CARD is actually posted upon the premises. Acceptance of fee is no guarantee that permit will be granted. PRESERVE THIS RECEIPT. In case permit cannot be granted the amount of the fee will be refunded upon return of the receipt less \$10.00 or 10% whichever is greater.

Demia

- WHITE - Applicant's Copy
- YELLOW - Office Copy
- PINK - Permit Copy

City of Portland, Maine - Building or Use Permit Application

389 Congress Street, 04101 Tel: (207) 874-8703, Fax: (207) 874-8716

Permit No: 05-1247	Issue Date: PERMIT ISSUED	City: 054 C003001
-----------------------	-------------------------------------	----------------------

Location of Construction: 14 Hill St	Owner Name: Bean Matthew	Owner Address: 14 Hill St	Phone: 207 121189
Business Name:	Contractor Name: Matthew Bean	Contractor Address: 14 Hill St Portland	Phone: 207 121189
Lessee/Buyer's Name:	Phone:	Permit Type: Alterations - Multi Family	Zone: R-6

Past Use: Residential multi unit	Proposed Use: Residential multi unit Amend permit#050753 remove decks and replace w/stairs	Permit Fee: \$30.00	Cost of Work: \$600.00	CEO District: 2
-------------------------------------	---	------------------------	---------------------------	--------------------

Proposed Project Description: Amend permit # 050753 remove decks and replace w/stairs	FIRE DEPT: <input type="checkbox"/> Approved <input type="checkbox"/> Denied INSPECTION: Use Group: R-2 Type: 5B Signature: <i>[Signature]</i>
--	--

Permit Taken By: dmartin	Date Applied For: 08/30/2005	Zoning Approval
-----------------------------	---------------------------------	------------------------

1. This permit application does not preclude the Applicant(s) from meeting applicable State and Federal Rules. 2. Building permits do not include plumbing, septic or electrical work. 3. Building permits are void if work is not started within six (6) months of the date of issuance. False information may invalidate a building permit and stop all work..	Special Zone or Reviews <input type="checkbox"/> Shoreland <input type="checkbox"/> Wetland <input type="checkbox"/> Flood Zone <input type="checkbox"/> Subdivision <input type="checkbox"/> Site Plan Maj <input type="checkbox"/> Min <input type="checkbox"/> MM <input type="checkbox"/> Date: 9/23/05	Zoning Appeal <input type="checkbox"/> Variance <input type="checkbox"/> Miscellaneous <input type="checkbox"/> Conditional Use <input type="checkbox"/> Interpretation <input type="checkbox"/> Approved <input type="checkbox"/> Denied Date:	Historic Preservation <input checked="" type="checkbox"/> Not in District or Landmark <input type="checkbox"/> Does Not Require Review <input type="checkbox"/> Requires Review <input type="checkbox"/> Approved <input type="checkbox"/> Approved w/Conditions <input type="checkbox"/> Denied Date: 9/23/05
	<i>Same conditions apply</i>		

CERTIFICATION

I hereby certify that I am the owner of record of the named property, or that the proposed work is authorized by the owner of record and that I have been authorized by the owner to make this application as his authorized agent and I agree to conform to all applicable laws of this jurisdiction. In addition, if a permit for work described in the application is issued, I certify that the code official's authorized representative shall have the authority to enter all areas covered by such permit at any reasonable hour to enforce the provision of the code(s) applicable to such permit.

SIGNATURE OF APPLICANT	ADDRESS	DATE	PHONE
------------------------	---------	------	-------

RESPONSIBLE PERSON IN CHARGE OF WORK, TITLE	DATE	PHONE
---	------	-------

City of Portland, Maine - Building or Use Permit

389 Congress Street, 04101 Tel: (207) 874-8703, Fax: (207) 874-8716

Permit No: 05-1247	Date Applied For: 08/30/2005	CBL: 054 C003001
-----------------------	---------------------------------	---------------------

Location of Construction: 14 Hill St	Owner Name: Bean Matthew	Owner Address: 14 Hill St	Phone:
Business Name:	Contractor Name: Matthew Bean	Contractor Address: 14 Hill St Portland	Phone (207) 712-1139
Lessee/Buyer's Name	Phone:	Permit Type: Alterations - Multi Family	

Proposed Use: Residential multi unit Amend permit#050753 remove decks and replace w/stairs	Proposed Project Description: Amend permit # 050753 remove decks and replace w/stairs
--	---

Dept: Zoning **Status:** Approved with Conditions **Reviewer:** Tammy Munson **Approval Date:** 09/23/2005

Note: **Ok to Issue:**

1) All of the previous approvals apply to this permit.

Dept: Building **Status:** Approved **Reviewer:** Tammy Munson **Approval Date:** 09/23/2005

Note: **Ok to Issue:**

DISPLAY THIS CARD ON PRINCIPAL FRONTAGE OF WORK

CITY OF PORTLAND

BUILDING DEPARTMENT

Please Read Application And Notes, If Any, Attached

PERMIT ISSUED

Permit Number: 051247
 OCT 3 2004

CITY OF PORTLAND

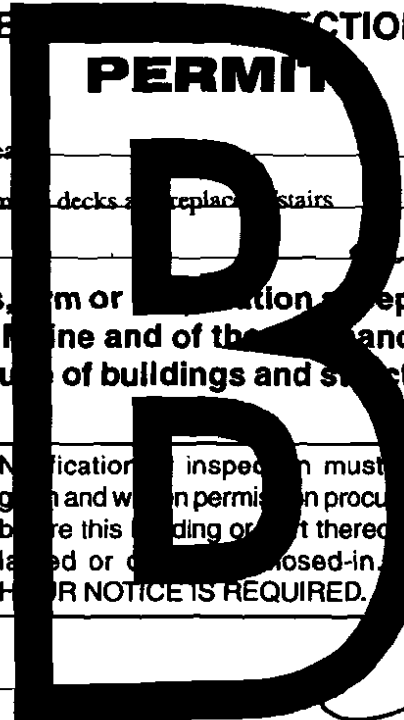

This is to certify that Ben Mathew / Matthew Ben

has permission to Amend permit # 050753 remove decks and replace stairs

AT 14 Hill St

054 C003001

provided that the person or persons, firm or corporation accepting this permit shall comply with all of the provisions of the Statutes of Maine and of the ordinances of the City of Portland regulating the construction, maintenance and use of buildings and structures, and of the application on file in this department.

Apply to Public Works for street line and grade if nature of work requires such information.

Notification of inspection must be given and when permission is procured before this building or part thereof is altered or closed-in. 24 HOUR NOTICE IS REQUIRED.

A certificate of occupancy must be procured by owner before this building or part thereof is occupied.

OTHER REQUIRED APPROVALS

Fire Dept. _____

Health Dept. _____

Appeal Board _____

Other _____

Department Name

[Signature] 9/23/05

Director - Building & Inspection Services

PENALTY FOR REMOVING THIS CARD

JOB 14 Hill St.

SHEET NO. SK-1

OF

CALCULATED BY MAB

DATE 8/28/05

CHECKED BY

DATE

SCALE AS NOTED

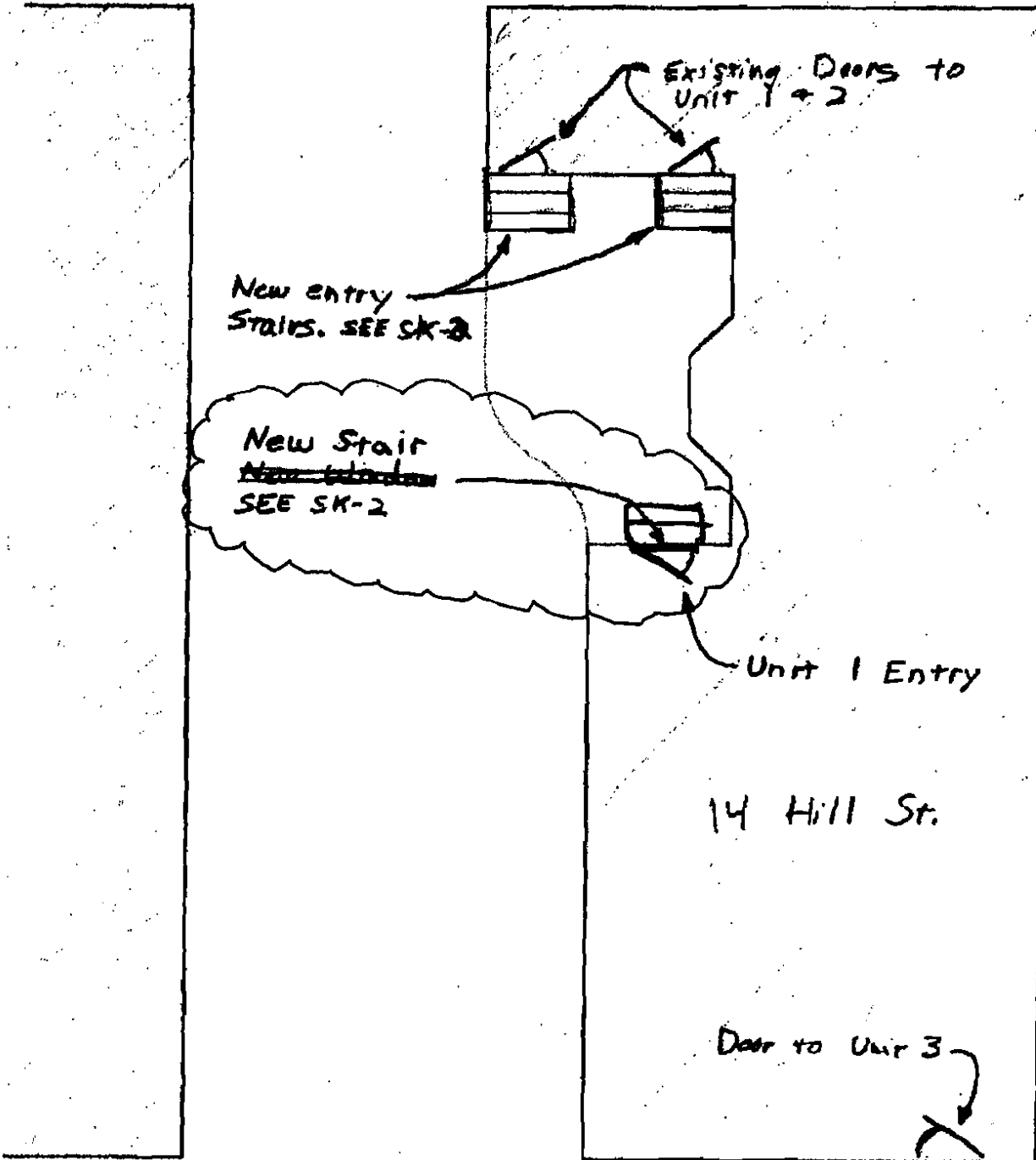

Site Plan

Scale: $\frac{1}{8}'' = 1'-0''$

JOB 14 Hill St.
 SHEET NO. SK-2 OF _____
 CALCULATED BY MAR DATE 8/29/65
 CHECKED BY _____ DATE _____
 SCALE AS NOTED

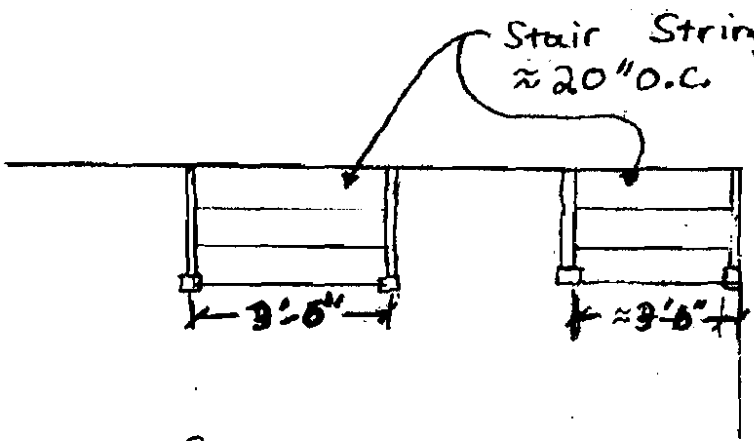

Plan View
 NTS

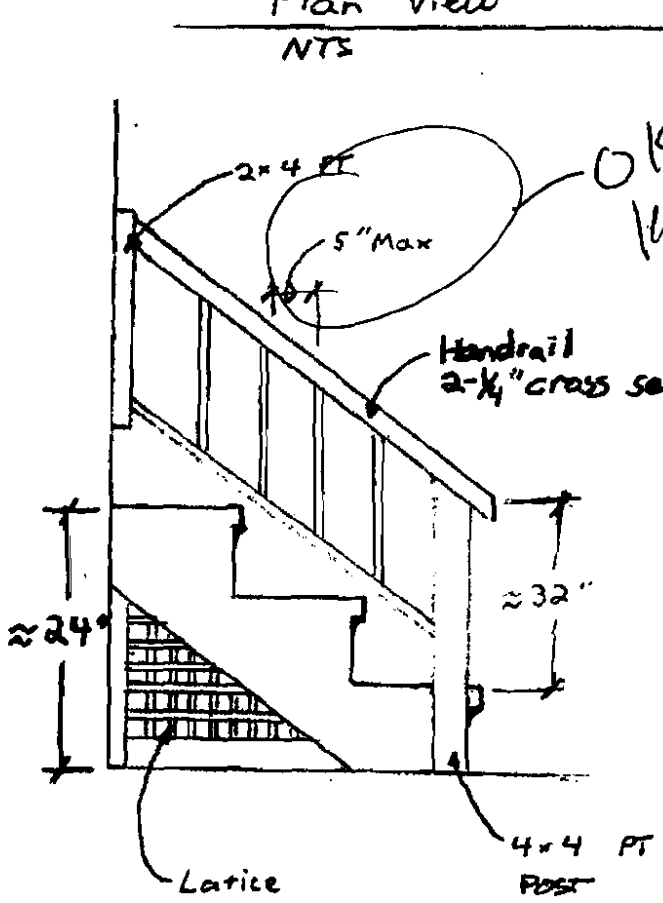

Stair Rail Detail
 NTS

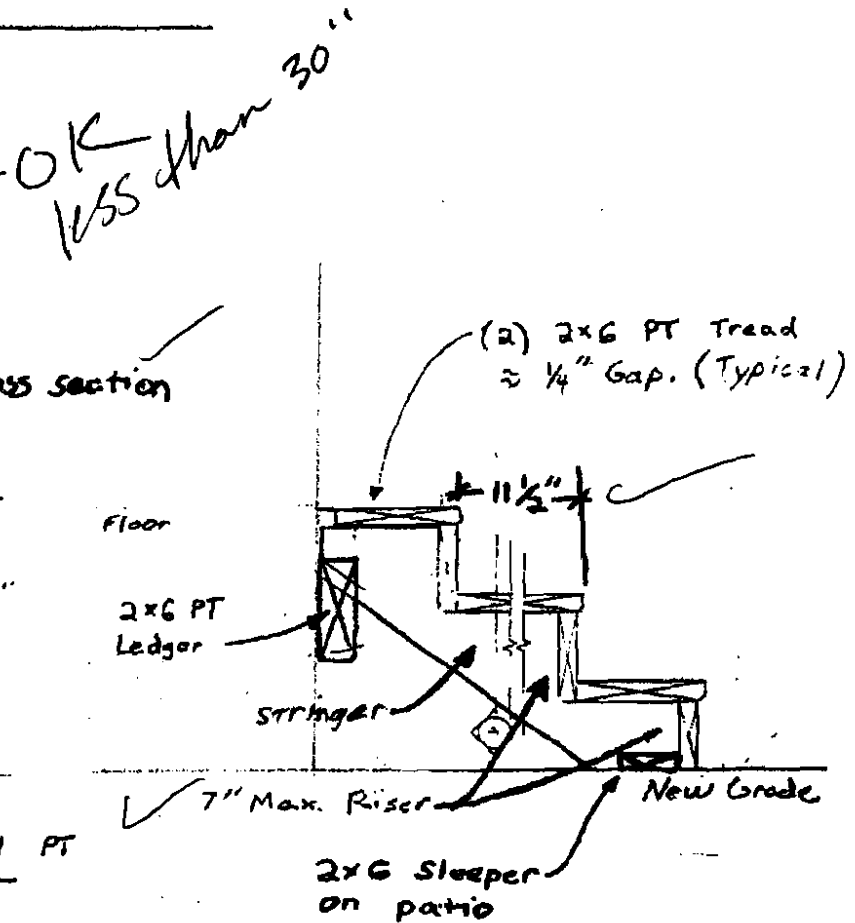

Stair Construction Detail
 NTS



Residential Building Permit Application

If you or the property owner owns real estate or personal property taxes or user charges on any property within the City, payment arrangements must be made before permits of any kind are accepted.

Location/Address of Construction: <u>14 Hill St., Portland ME</u>		
Total Square Footage of Proposed Structure <u>0</u>	Square Footage of Lot <u>2,253</u>	
Tax Assessor's Chart, Block & Lot Chart# <u>54</u> Block# <u>C</u> Lot# <u>3</u>	Owner: <u>Matthew Bean</u>	Telephone: <u>(207) 712-1139</u>
Lessee/Buyer's Name (If Applicable) <u>—</u>	Applicant name, address & telephone: <u>Matthew Bean</u> <u>14 Hill St.</u> <u>Portland ME 04101</u>	Cost Of Work: <u>\$ 600.00</u> Fees: <u>\$ 30.00</u>
Current Specific use: <u>3 family Residential</u>		
Proposed Specific use: <u>3 family Residential</u>		
Project description: <u>Remove decks and replace with steps.</u> <u>(Add 3rd Set of Stairs)</u>		
Contractor's name, address & telephone: <u>Same as above</u>		
Who should we contact when the permit is ready: <u>Amend # 050753</u>		
Mailing address:		

DEPT OF BUILDING INSPECTION
CITY OF PORTLAND, ME

AUG 29 2005

RECEIVED

Phone:

Please submit all of the information outlined in the Residential Application Checklist. Failure to do so will result in the automatic denial of your permit.

At the discretion of the Planning and Development Department, additional information may be required prior to permit approval. For further information stop by the Building Inspections office, room 315 City Hall or call 874-8703.

I hereby certify that I am the Owner of record of the named property, or that the owner of record authorizes the proposed work and that I have been authorized by the owner to make this application as his/her authorized agent. I agree to conform to all applicable laws of this jurisdiction. In addition, if a permit for work described in this application is issued, I certify that the Code Official's authorized representative shall have the authority to enter all areas covered by this permit at any reasonable hour to enforce the provisions of the codes applicable to this permit.

Signature of applicant: <u>Matthew A. Bean</u>	Date: <u>8/29/05</u>
--	----------------------

Permit Fee: \$30.00 for the first \$1000.00 Construction Cost, \$9.00 per additional \$1000.00 cost

This is not a Permit; you may not commence any work until the Permit is issued.