

NOTE:
SEE DETAIL C2/C50.1 FOR PIPE CONNECTION AND INSULATION REQUIREMENTS.

NEW SEWER & NEW STORM DRAIN PROFILE D5
SCALE: H: 1"=20'/V: 1"=4'

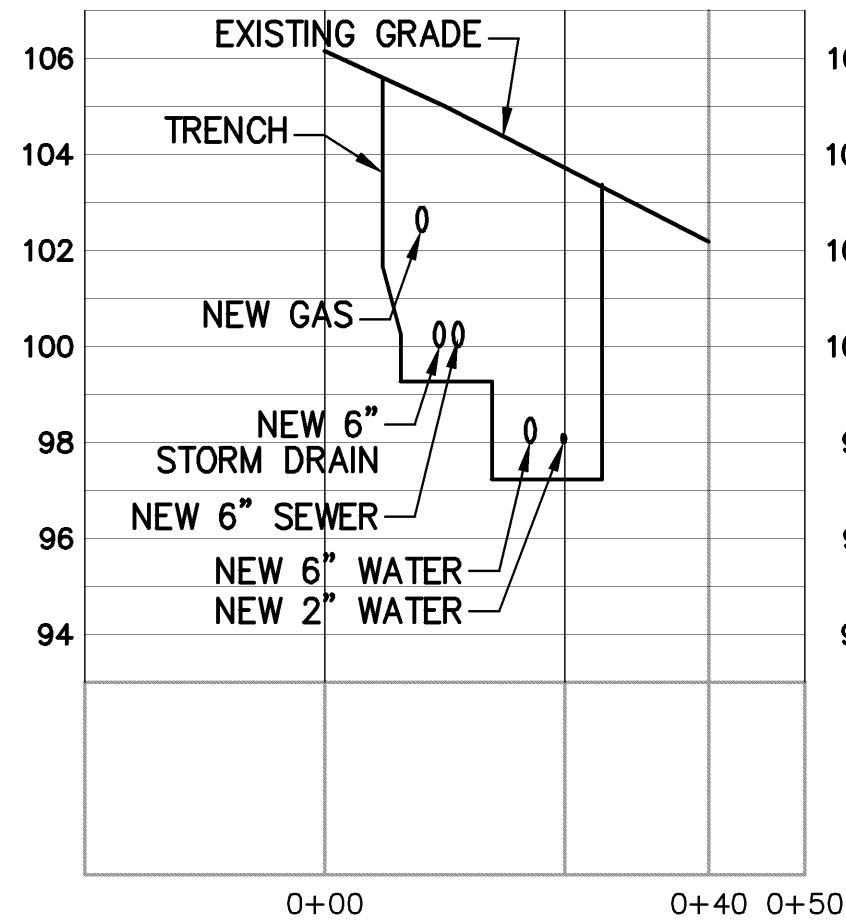

NOTE:
SEE DETAIL B3/C50.1 FOR BEDDING REQUIREMENTS.

NEW UTILITY SECTION D3
SCALE: H: 1"=20'/V: 1"=4'

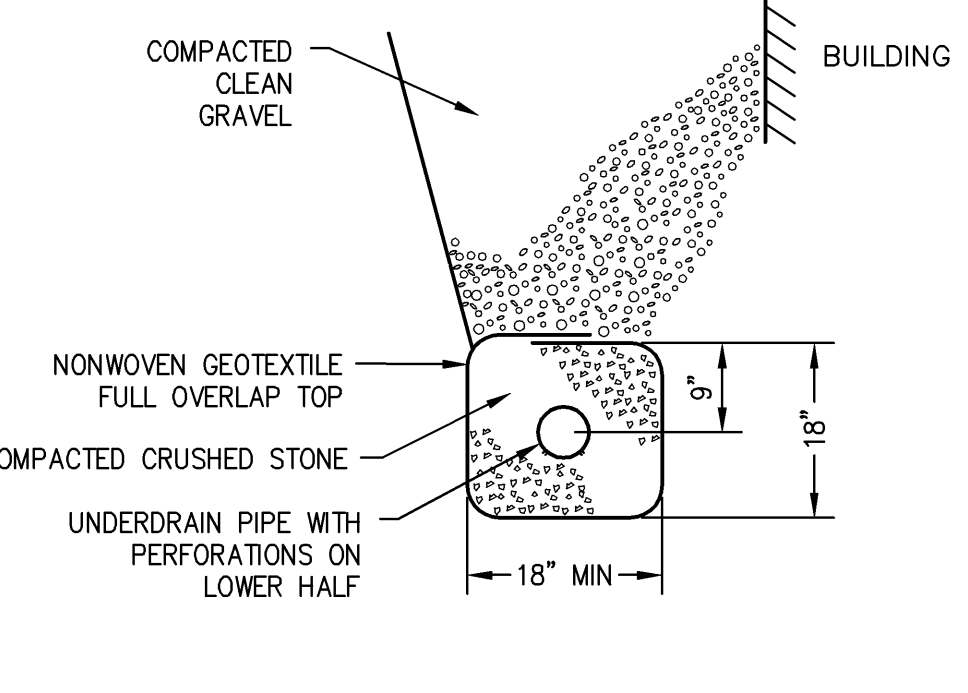

UNDERDRAIN OR FOUNDATION DRAIN D2
NOT TO SCALE

NOTE: SUBMIT FOR REVIEW DRAWN PROFILES AND SECTIONS PRIOR TO CONSTRUCTING P.C. CONC. UNIT RETAINING WALLS. FOR WALLS MORE THAN 5' TALL, SUBMIT DESIGN DRAWINGS AND COMPUTATIONS STAMPED BY A PROFESSIONAL ENGINEER. LENGTH AND NUMBER OF GEGRID LAYERS MAY VARY BASED ON WALL DESIGN.

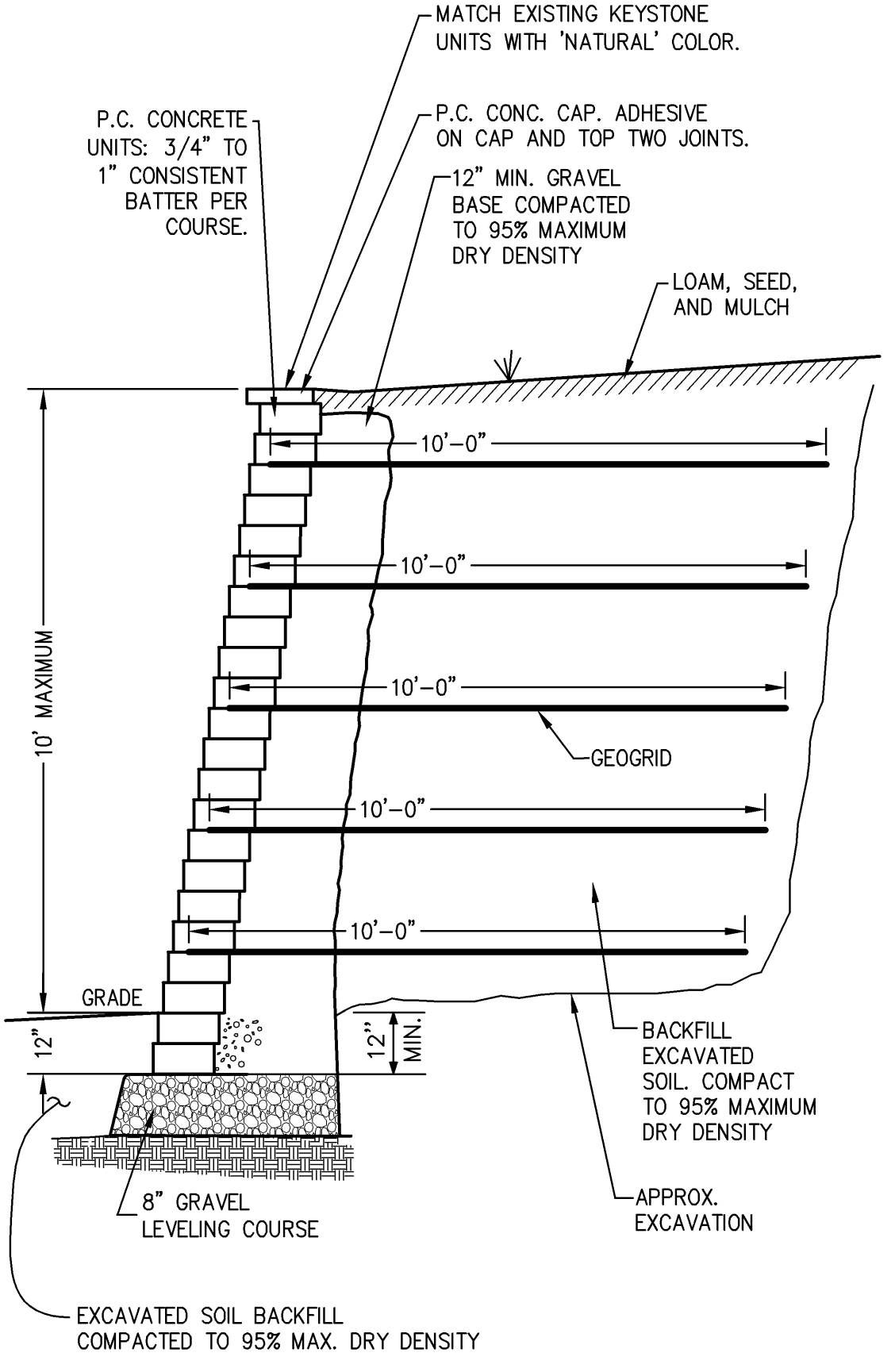

PRECAST CONCRETE UNIT RETAINING WALL C1
NOT TO SCALE

HARRIMAN ASSOCIATES
Architects • Engineers
One Auburn Business Park
Auburn, Me 04210
207.754.5100 tel
207.783.3017 fax
www.harriman.com
Building communities since 1970
© 2004

Project Title
MAINE HEART SURGICAL ASSOC. NEW OFFICE BLDG.
PORTLAND, ME

HA Project No. 04180

Key Plan

GENERAL DATA FOR BLOCKING STANDARD FITTINGS
MINIMUM SURFACE AREA OF CONCRETE BLOCK AGAINST UNDISTURBED EARTH - SQ.FT.

| PIPE SIZE | HYDRANT, PLUG, CAP, TEE | 90° BEND | 45° BEND | 22.5° BEND | 11.25° BEND |
|-----------|-------------------------|----------|----------|------------|-------------|
| 4" | 4 | 4 | 4 | 4 | 2 |
| 6" | 8 | 10 | 10 | 6 | 3 |
| 8" | 12 | 16 | 14 | 12 | 4 |
| 10" | 18 | 26 | 20 | 16 | 5 |
| 12" | 26 | 36 | 28 | 20 | 7 |
| 14" | 36 | 50 | 36 | 28 | 9 |
| 16" | 46 | 64 | 46 | 36 | 12 |

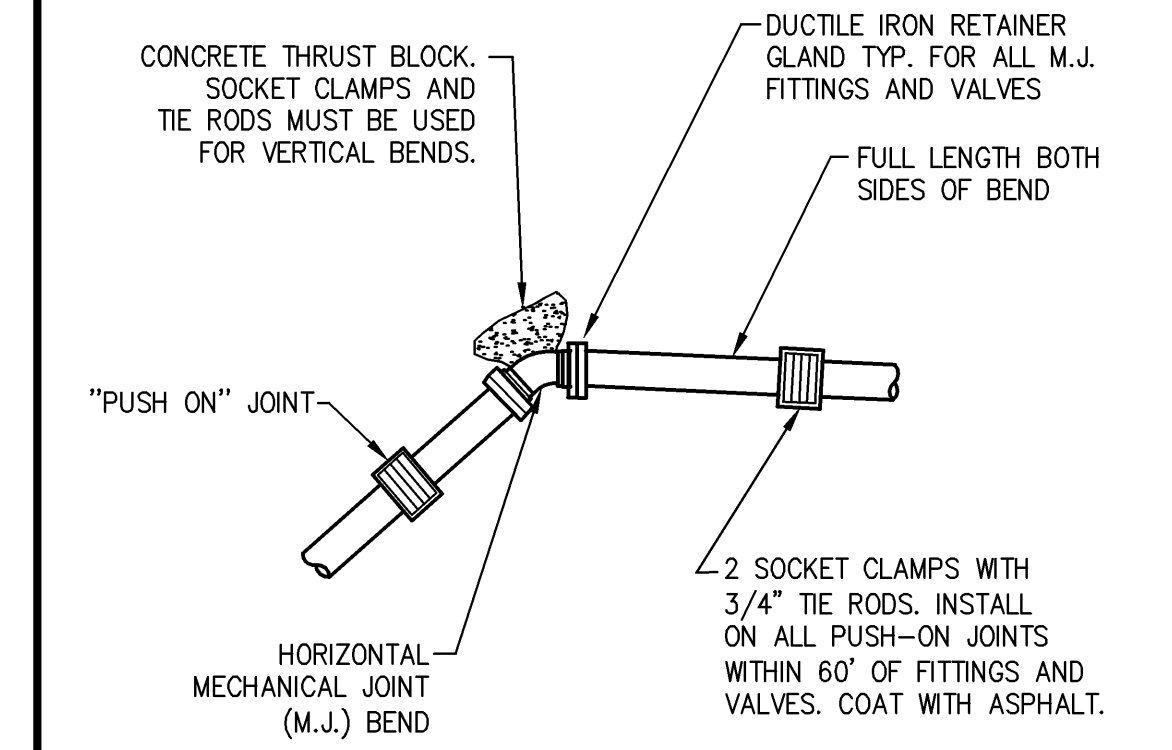

RESTRAINT AT FITTINGS WATER LINES C5
NOT TO SCALE

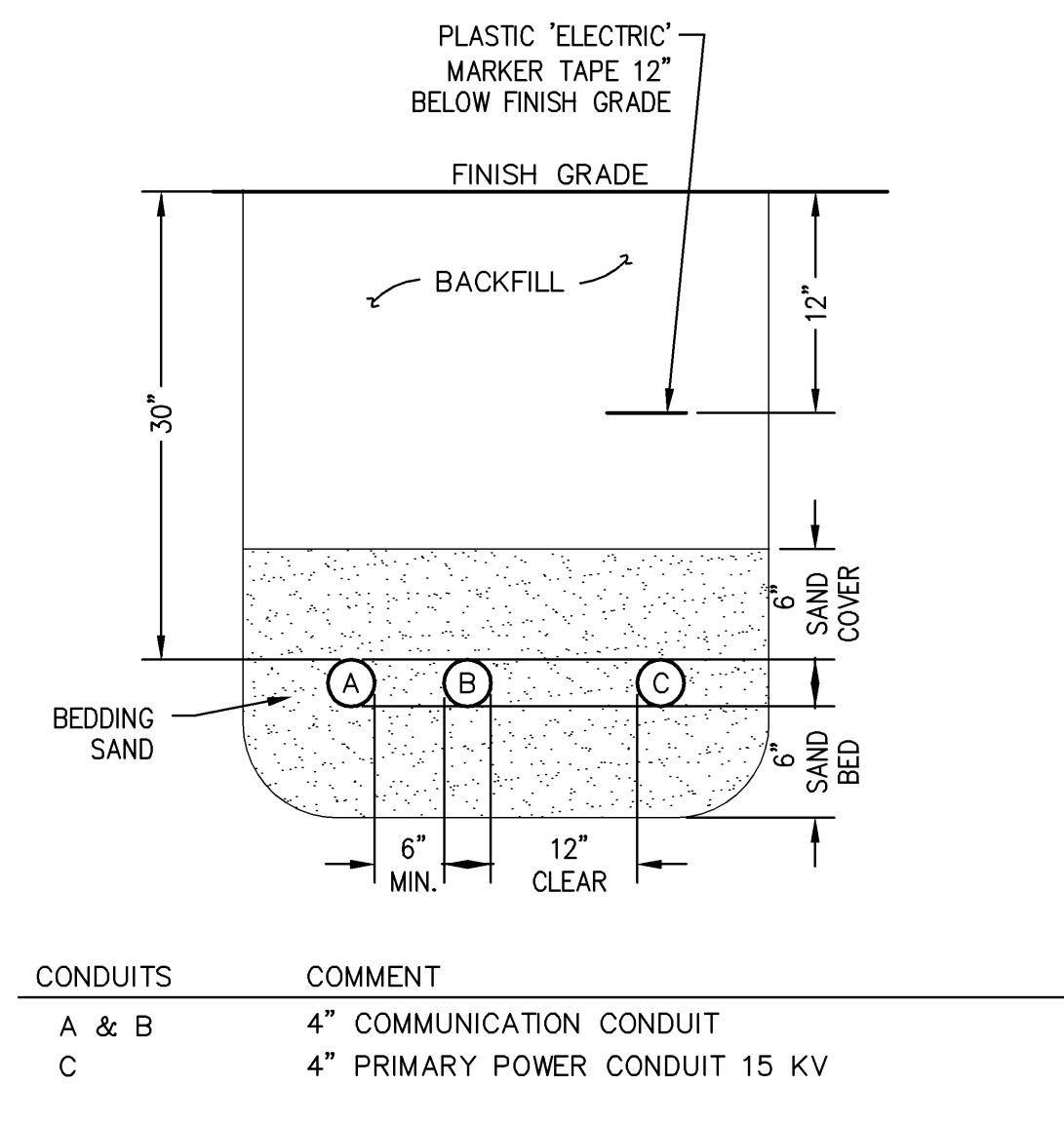

DUCT BANK SECTION C4
NOT TO SCALE

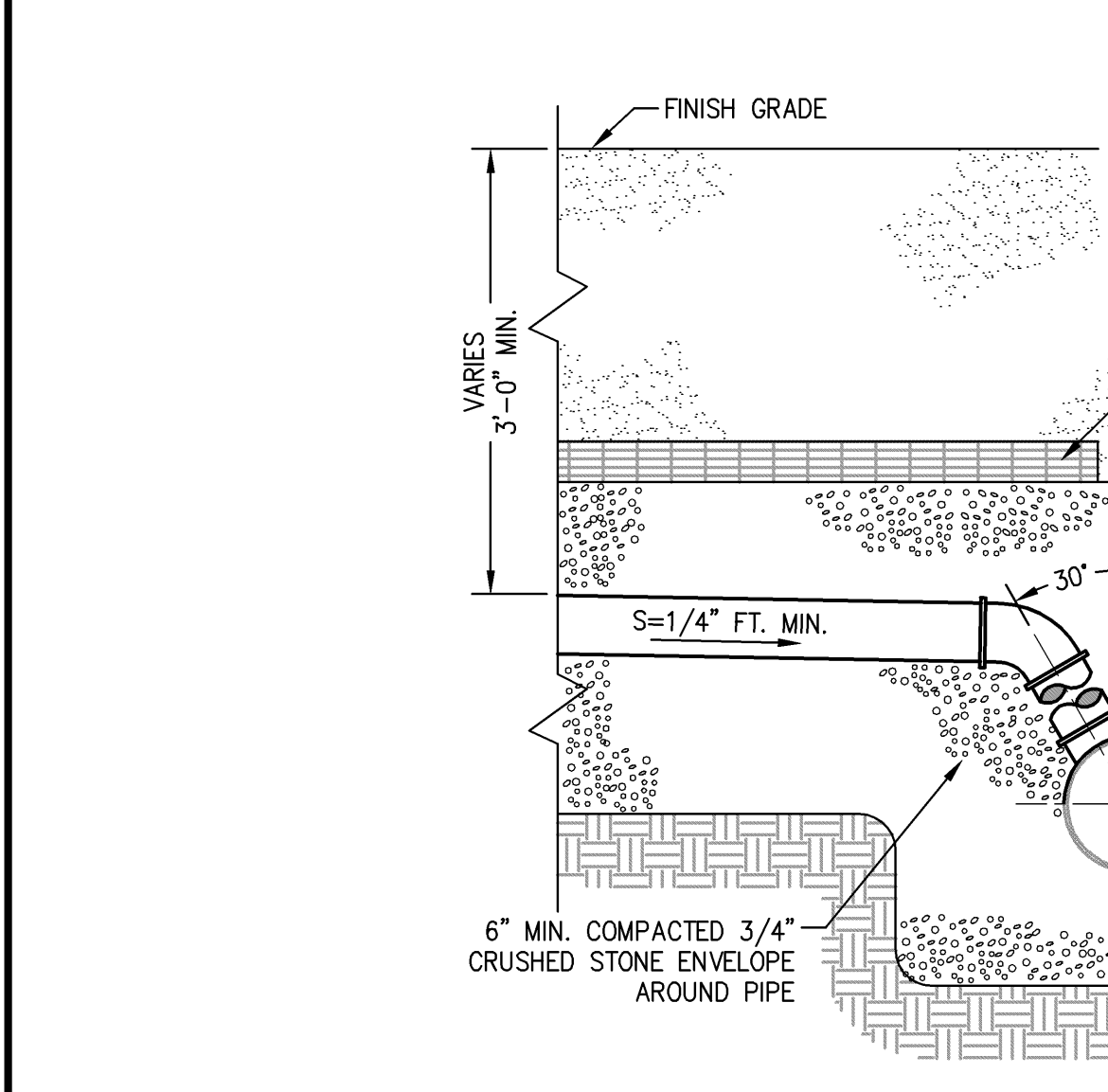

HORIZONTAL SEWER SERVICE CONNECTION C2
NOT TO SCALE

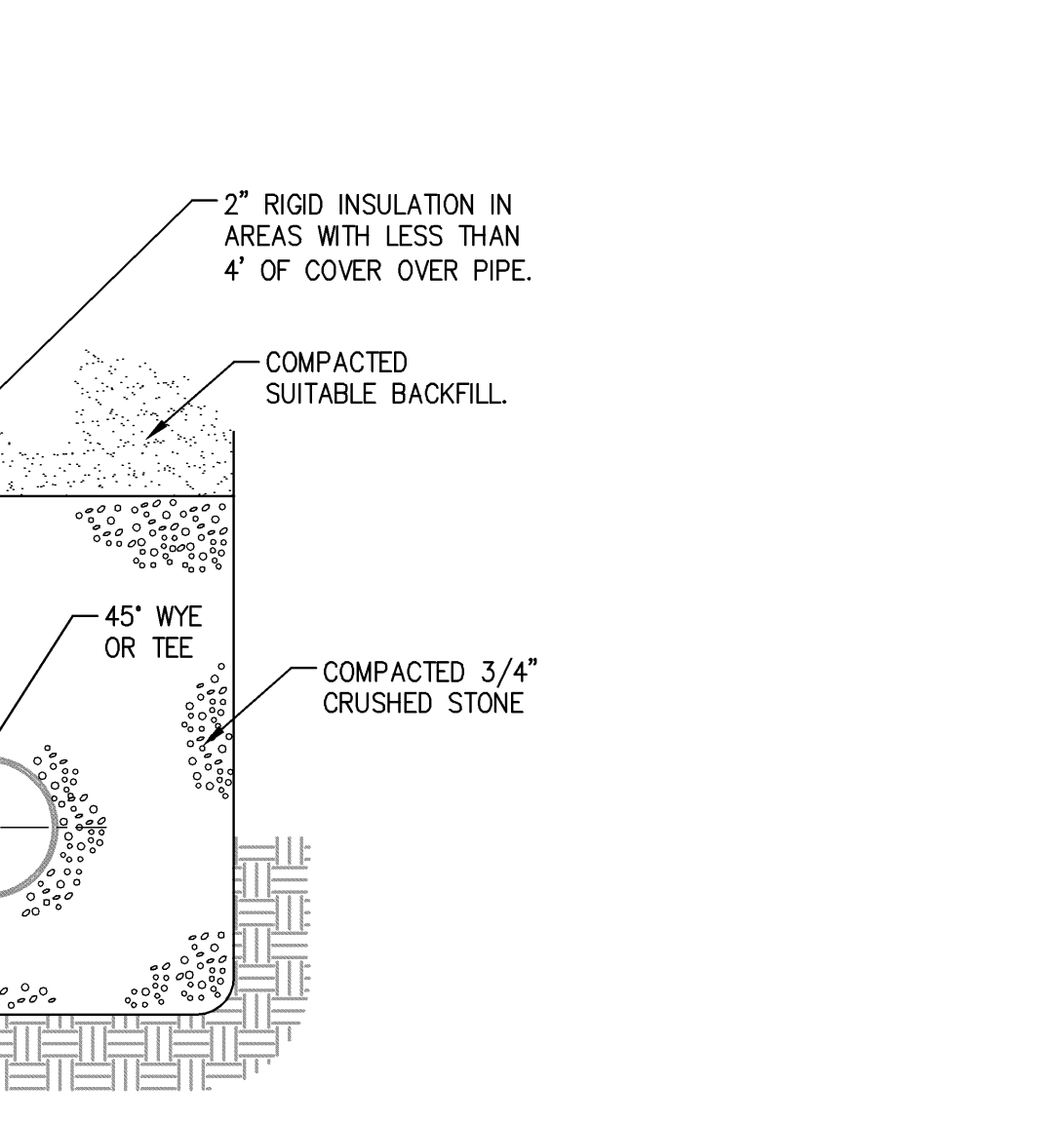

NEW UNDERGROUND LIGHTING CONDUIT C6
NOT TO SCALE

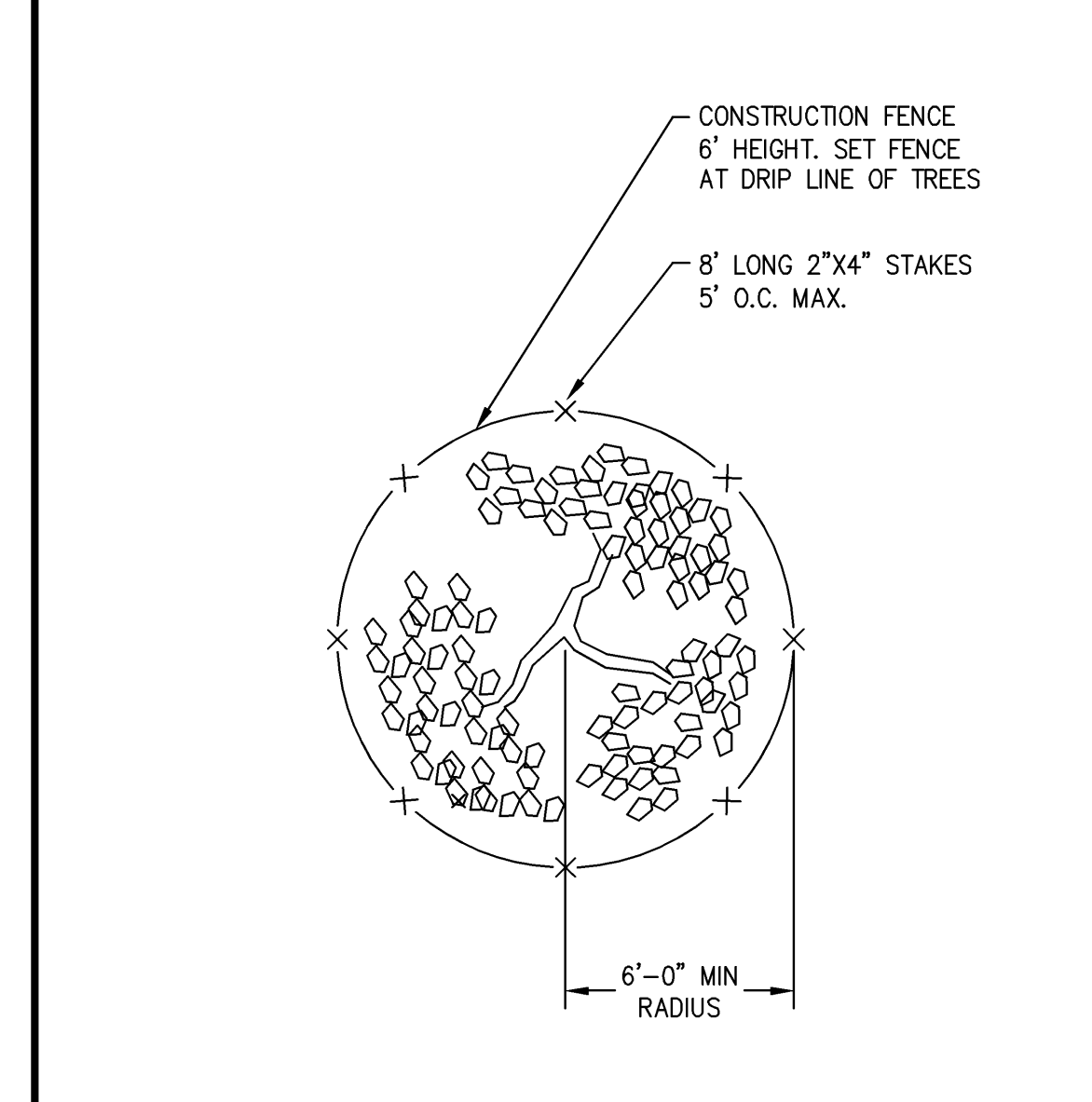

TEMPORARY TREE PROTECTION DETAIL B5
NOT TO SCALE

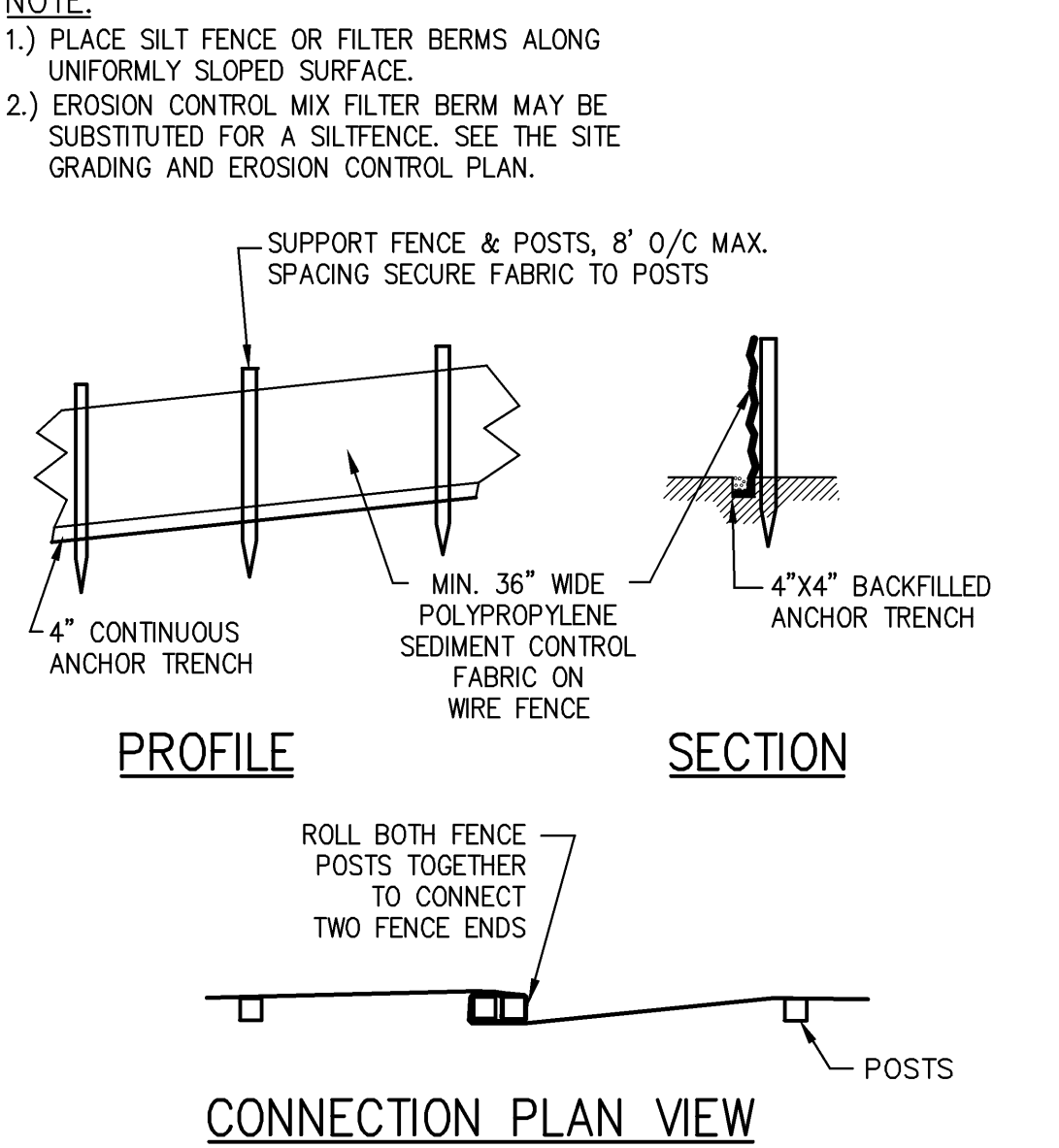

SILT FENCE B4
NOT TO SCALE

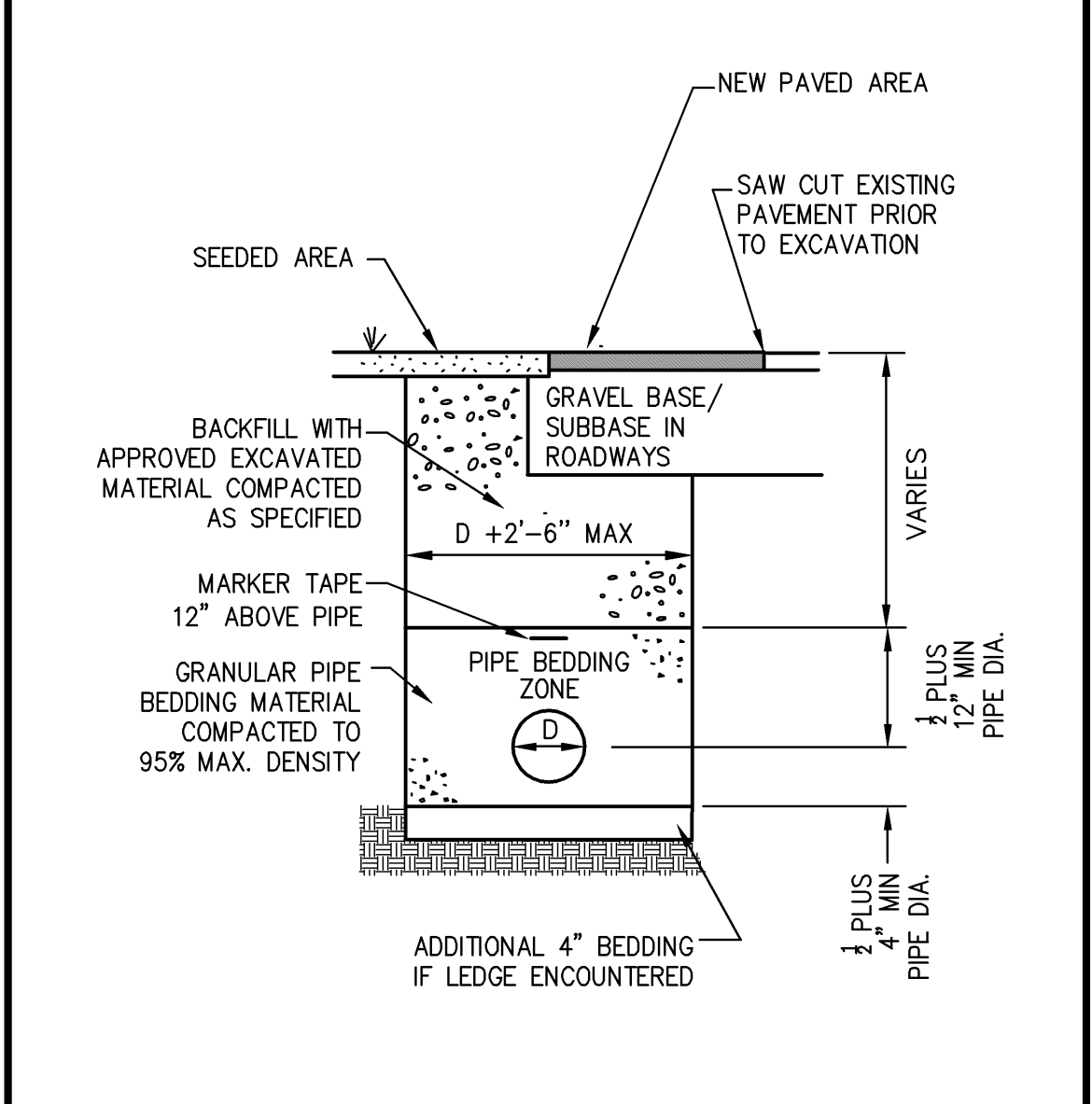

PIPE TRENCH B3
NOT TO SCALE

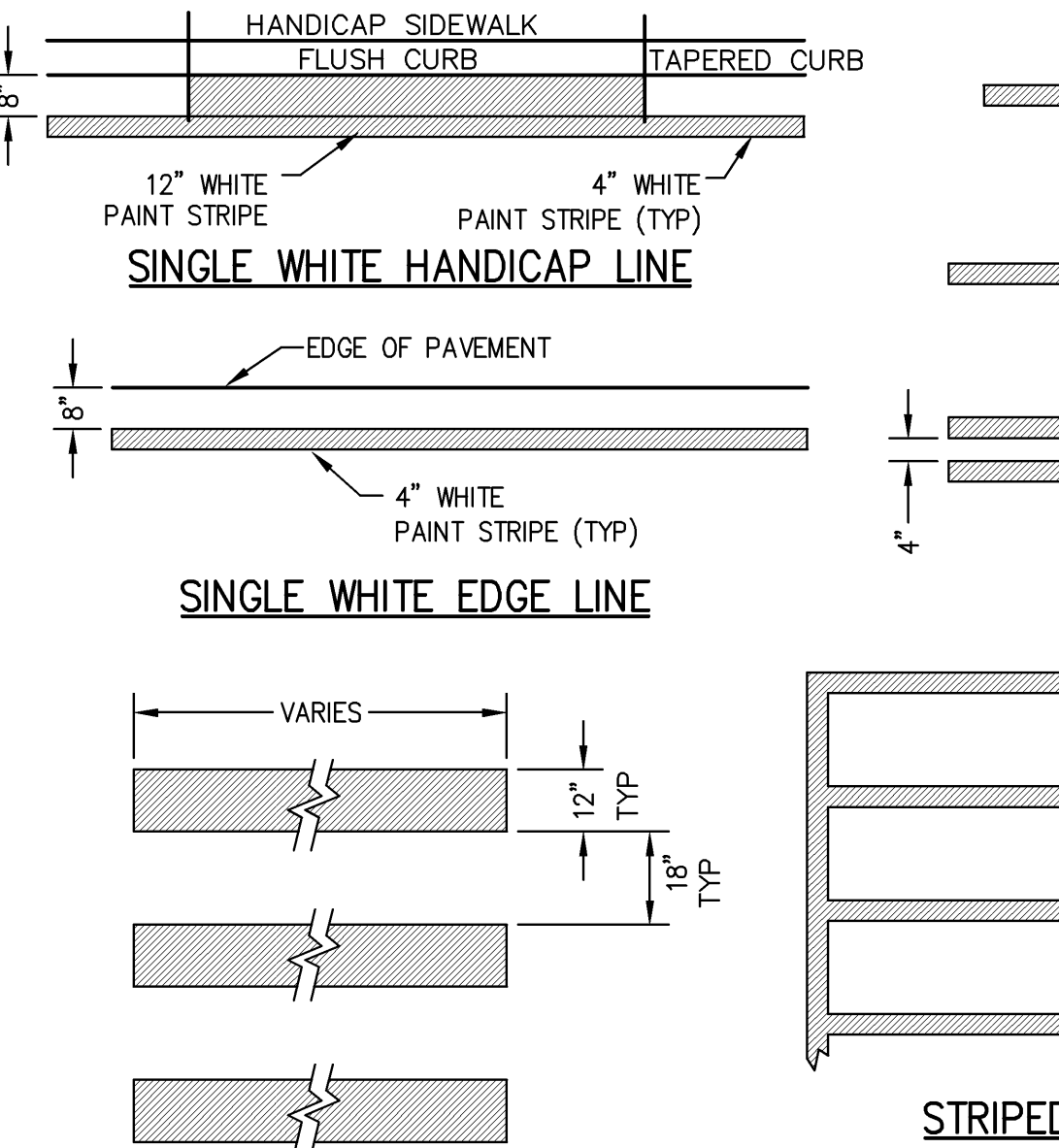

PEDESTRIAN CROSSWALK B1
NOT TO SCALE

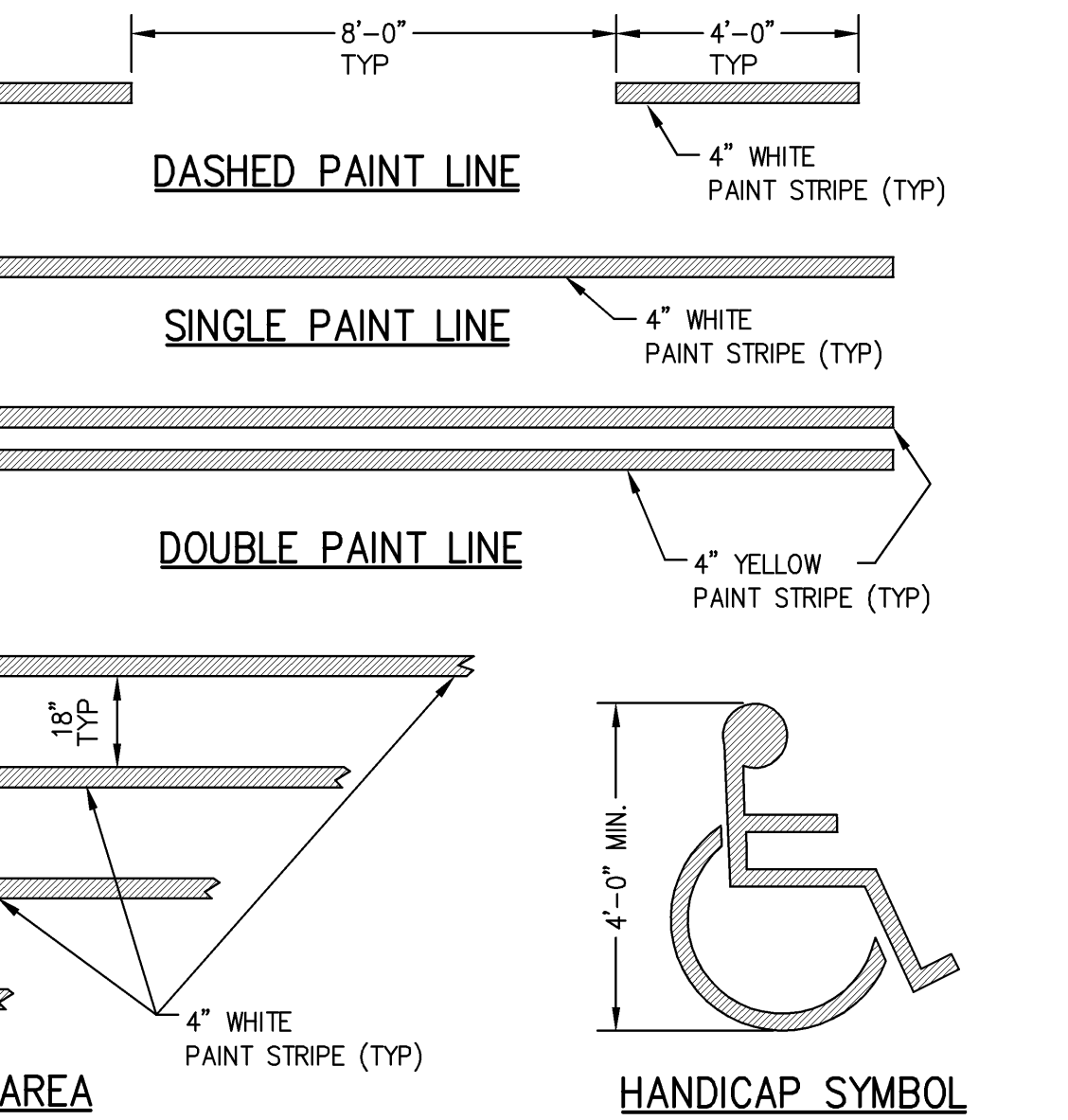

STANDARD PAINT STRIPING B1
NOT TO SCALE

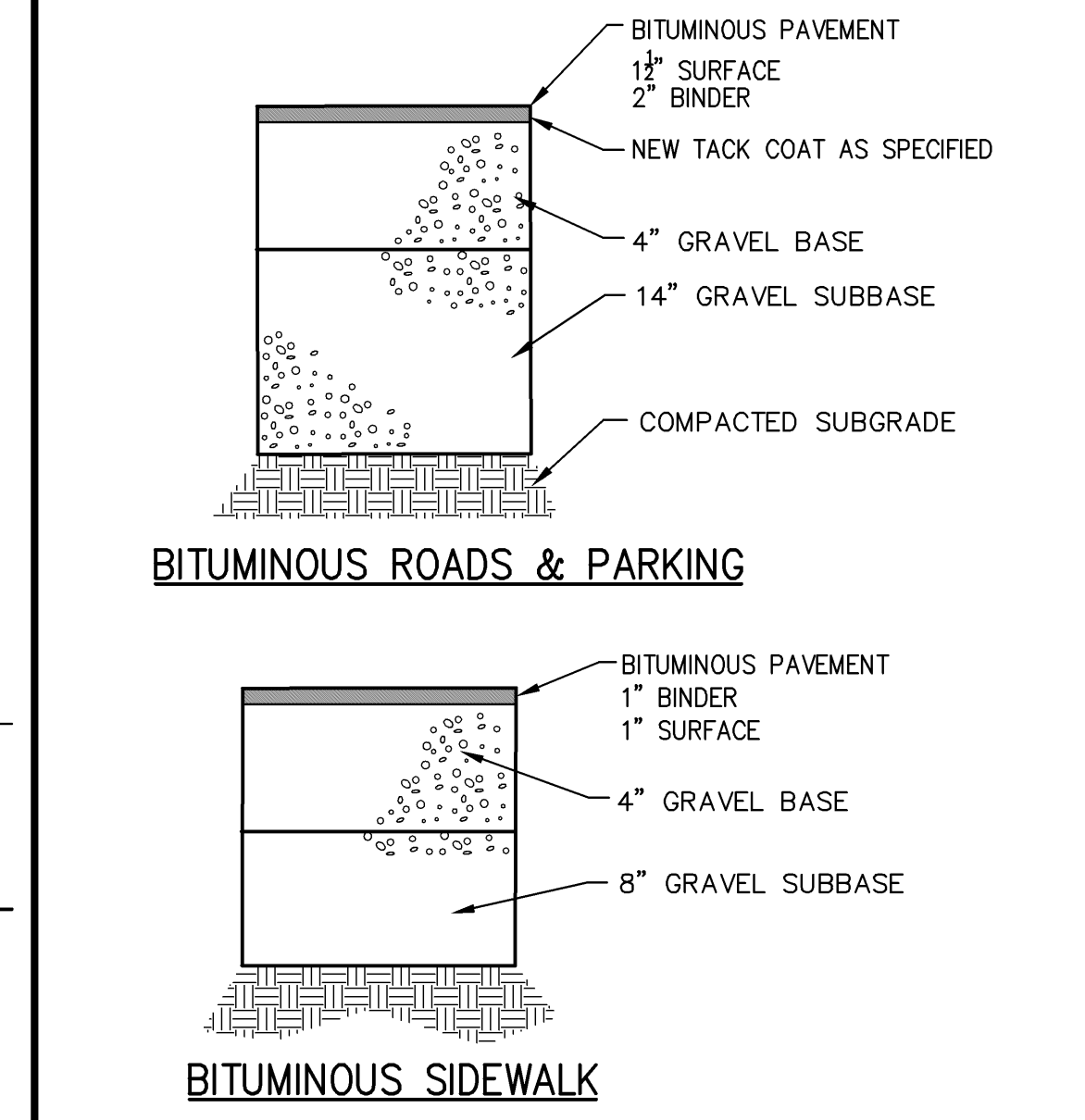

BITUMINOUS PAVEMENT DETAILS A5
NOT TO SCALE

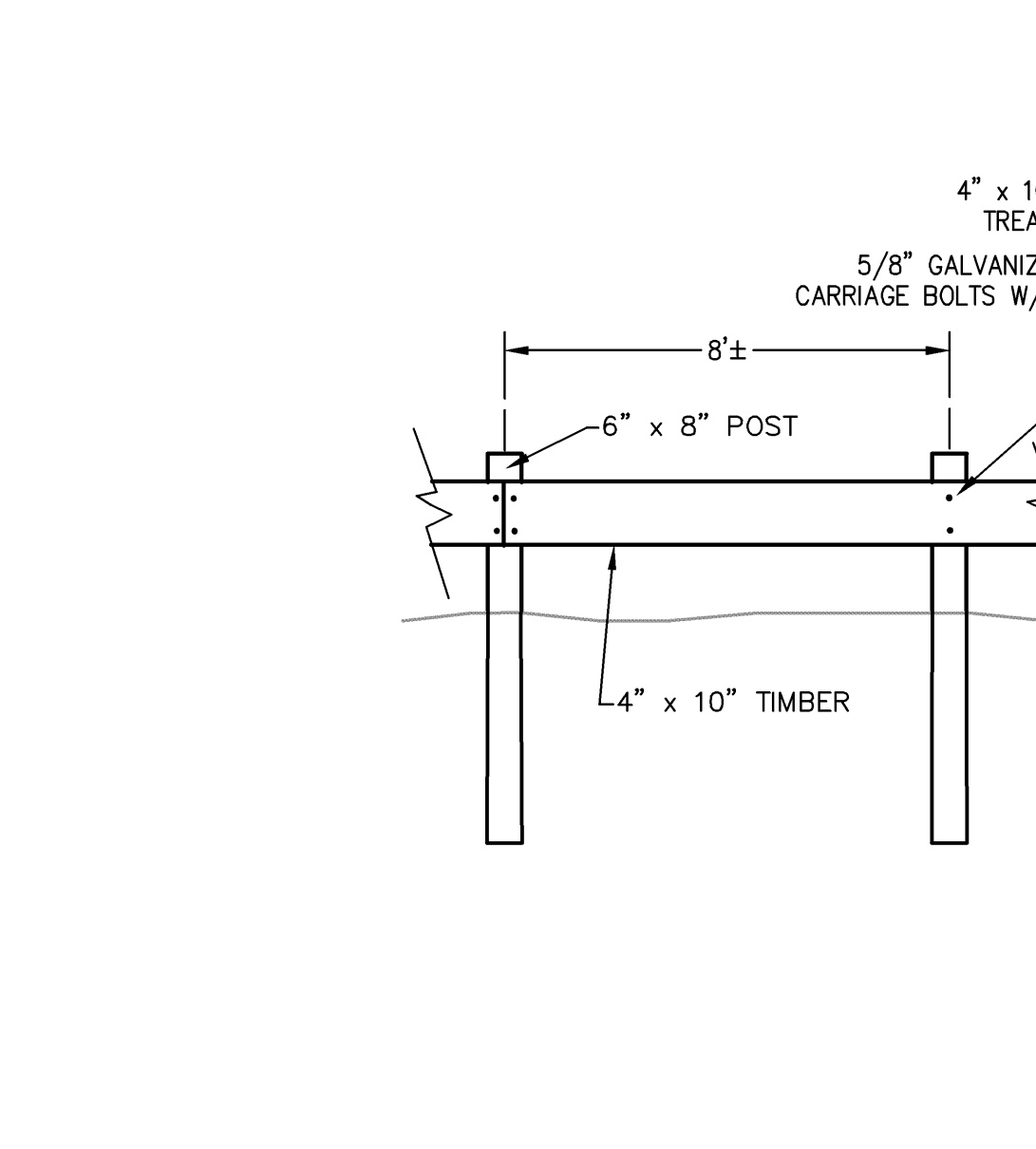

WOODEN GUARDRAIL DETAIL A3
NOT TO SCALE

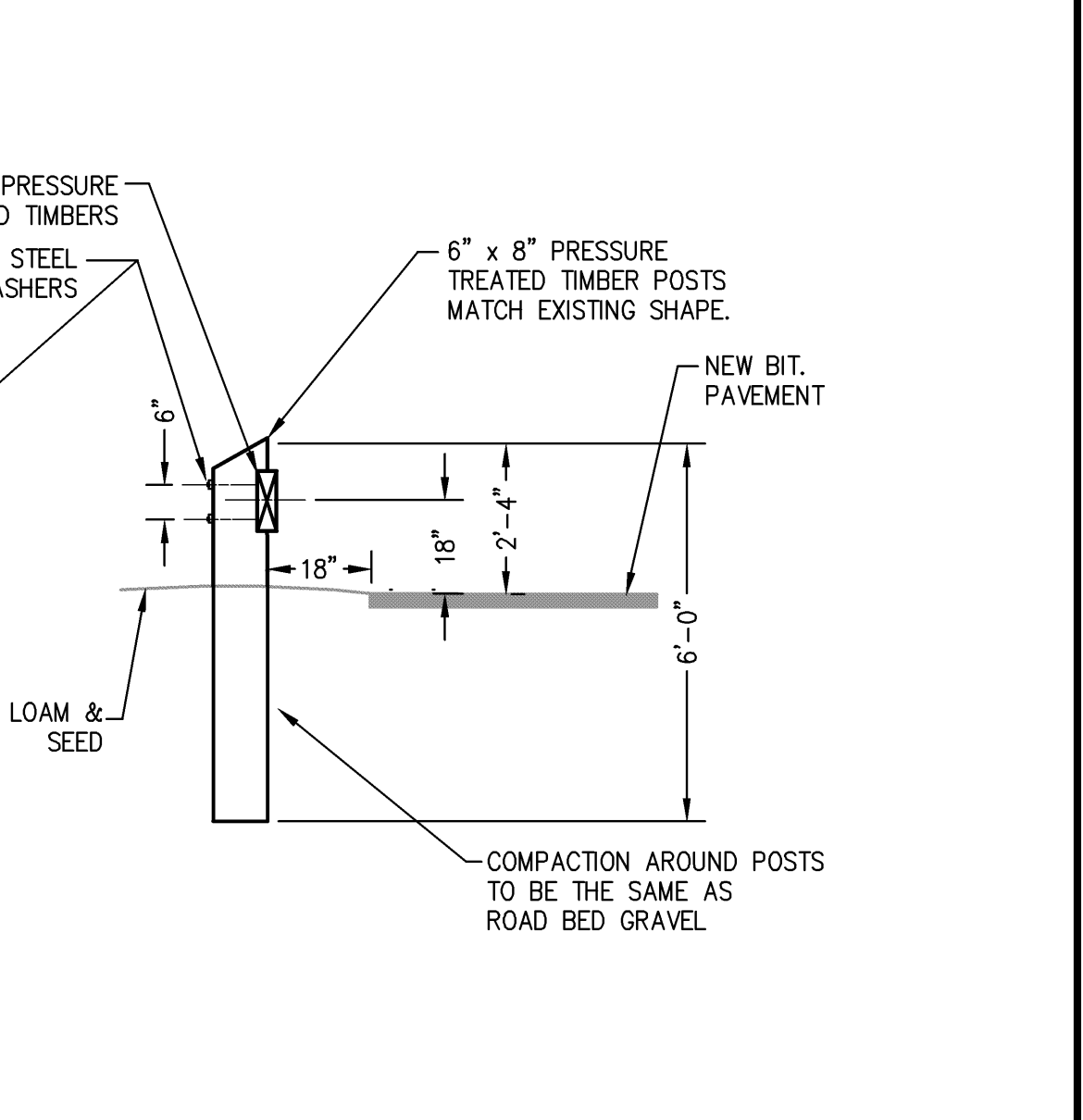

BITUMINOUS CAPE COD BERM CURB A2
NOT TO SCALE

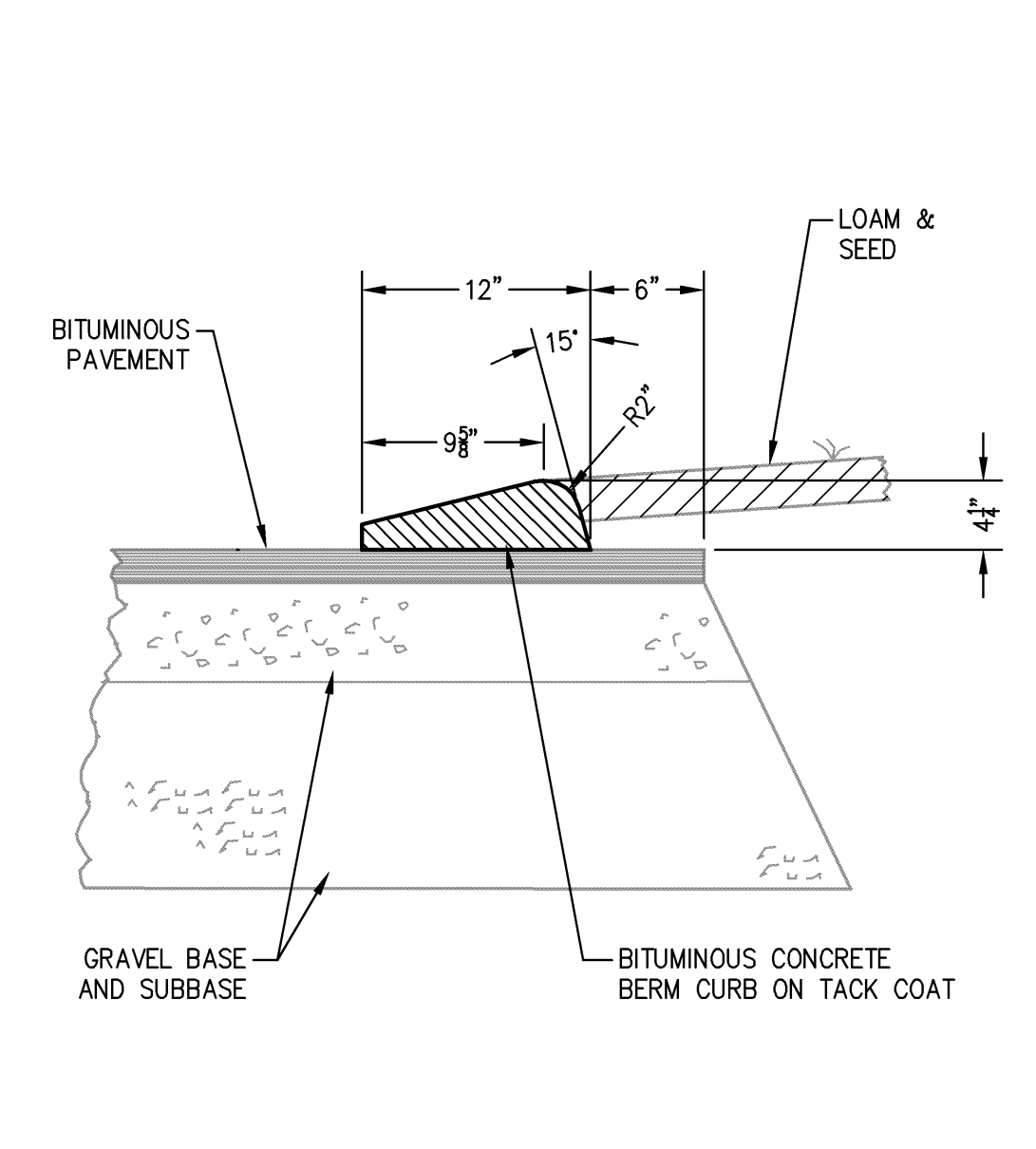

C.I.P. CONCRETE SURFACING A6
NOT TO SCALE

STANDARD SITE LEGEND A1
NOT TO SCALE

EXISTING: BUILDING, BIT. CONC. PAVEMENT, CURB, CHAIN-LINK FENCE, GUARDRAIL, SIGN, BOLLARDS, HANDICAP RAMP, TREES, 1" CONTOUR, SPOT ELEVATION, GRADE TO DRAIN, SILT FENCE, HAY BALE, BARK/STONE CHECK DAM, RIP-RAP (SIZE NOTED), CATCH BASIN/RAIN INLET, MANHOLE, WATER VALVE, HYDRANT, UTILITY POLE, LIGHT BOLLARD, SPOT LIGHT, WALL PACK, TRANSFORMER PAD, POLE, TRANSFORMER, UNDERDRAIN, STORM DRAIN, UNDERSEWER, SANITARY SEWER, WATER LINE, IRRIGATION LINE, FUEL, PROPANE, UNDERGROUND ELECTRICAL, LIGHTING, TELEPHONE, & CABLE, AERIAL ELECTRICAL, TELEPHONE, AND CABLE, PROPERTY LINE, NOT IN CONTRACT, N.L.C.

PROPOSED: WITH DOOR SHOWN, WITH LABEL, TYPICALLY SEWER, DRAIN MANHOLE (DMH) IF NOTED, BOXES INDICATE AIM DIRECTION AND NUMBER OF HEADS OTHER THAN ONE. SEE FEATURE SCHEDULE.

| Mark | Date | Description |
|----------|------|--------------------------|
| 04-28-05 | | ISSUED FOR BID |
| 04-27-05 | | PLANNING BOARD REVISIONS |
| 02-23-05 | | PLANNING BOARD |
| 02-11-05 | | REVIEW |
| 01-10-05 | | D.D. REVIEW |

Drawing Status

Drawing Title
SITE DETAILS
PA / PE: FLC Drawn By: MRL/NHS
Drawing Number
C50.1