

- TYPE (A3) NON-RATED
5.5/8\"/>
- TYPE (A2) NON-RATED
7.5/8\"/>
- TYPE (A3) 2 HR RATED
5.5/8\"/>
- TYPE (A4) 2 HR RATED
7.5/8\"/>

(A3) PARTITION TYPE SCHEDULE
SCALE: 1 1/2\"/>

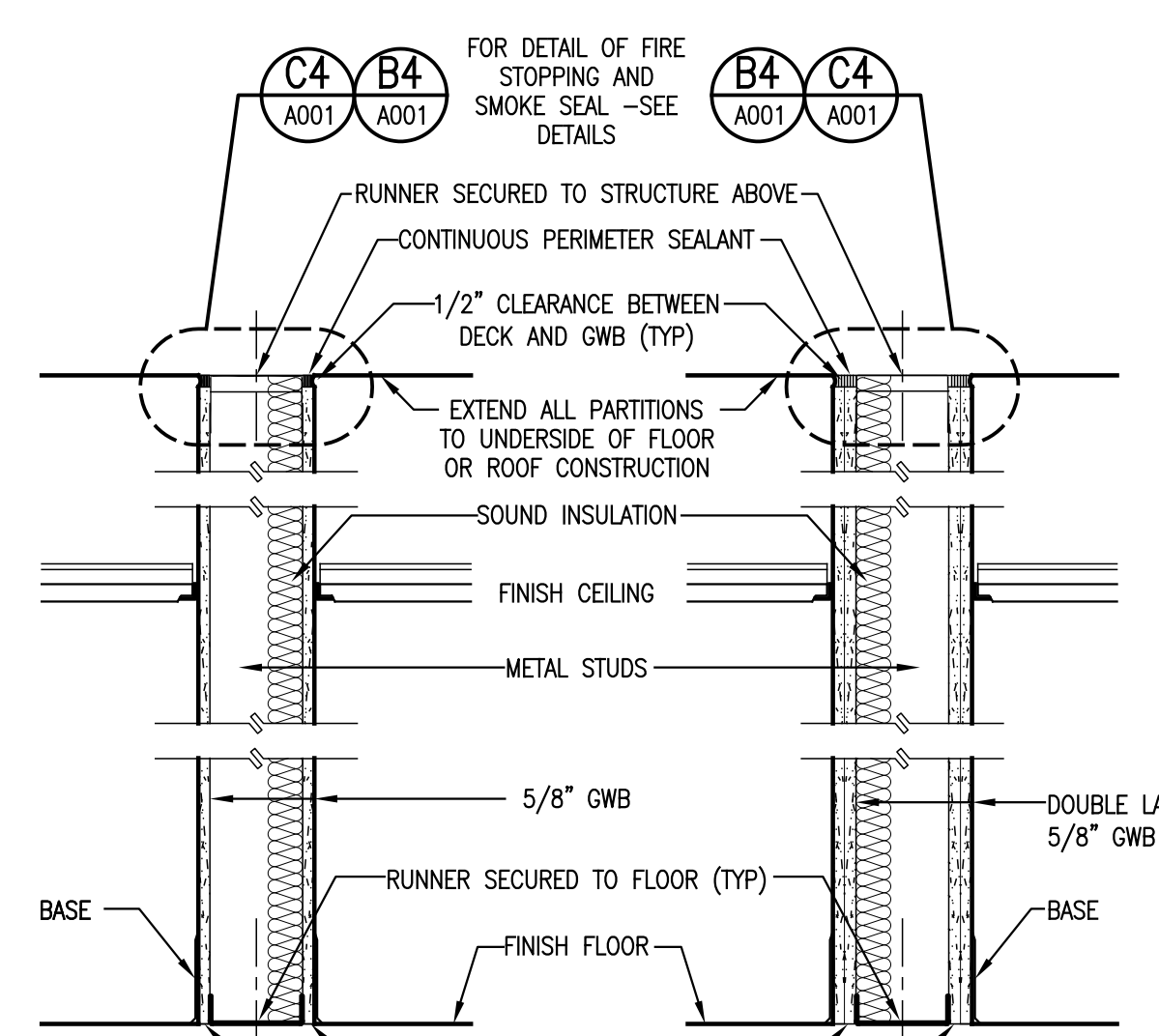

- TYPE (B3) NON-RATED
(STC 45) ONE LAYER 5/8\"/>
- TYPE (B1) NON-RATED
(STC 45) ONE LAYER 5/8\"/>
- TYPE (B2) 1 HR RATED
(STC 45) ONE LAYER 5/8\"/>
- TYPE (B3) 1 HR RATED
(STC 45) ONE LAYER 5/8\"/>

(B3) PARTITION TYPE SCHEDULE
SCALE: 1 1/2\"/>

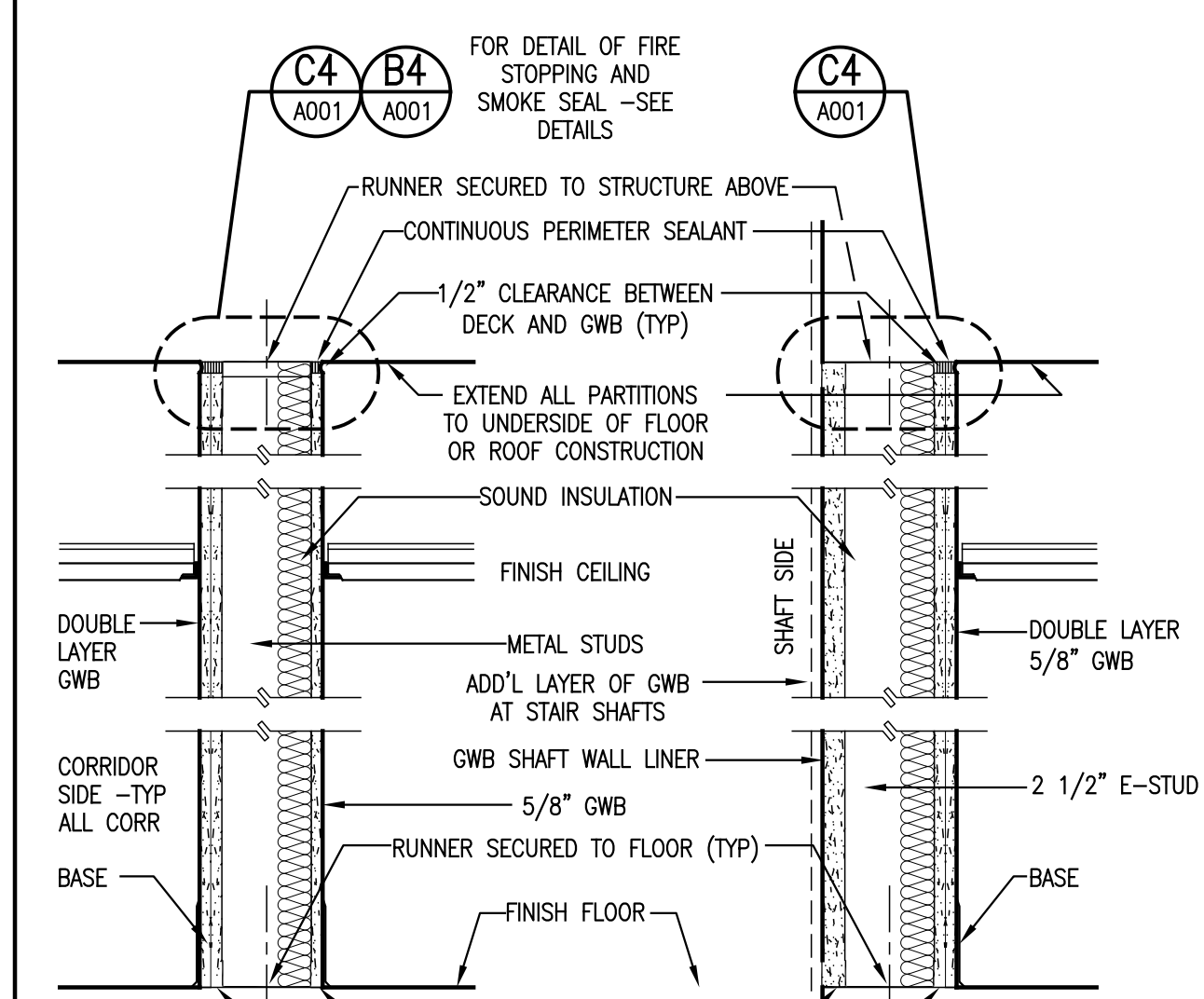

- TYPE (C3) NON-RATED
(STC 50) DOUBLE LAYER 5/8\"/>
- TYPE (C1) NON-RATED
(STC 50) DOUBLE LAYER 5/8\"/>
- TYPE (C2) 1 HR RATED
(STC 50) DOUBLE LAYER 5/8\"/>
- TYPE (C3) 1 HR RATED
(STC 50) DOUBLE LAYER 5/8\"/>

(C3) PARTITION TYPES SCHEDULE
SCALE: 1 1/2\"/>

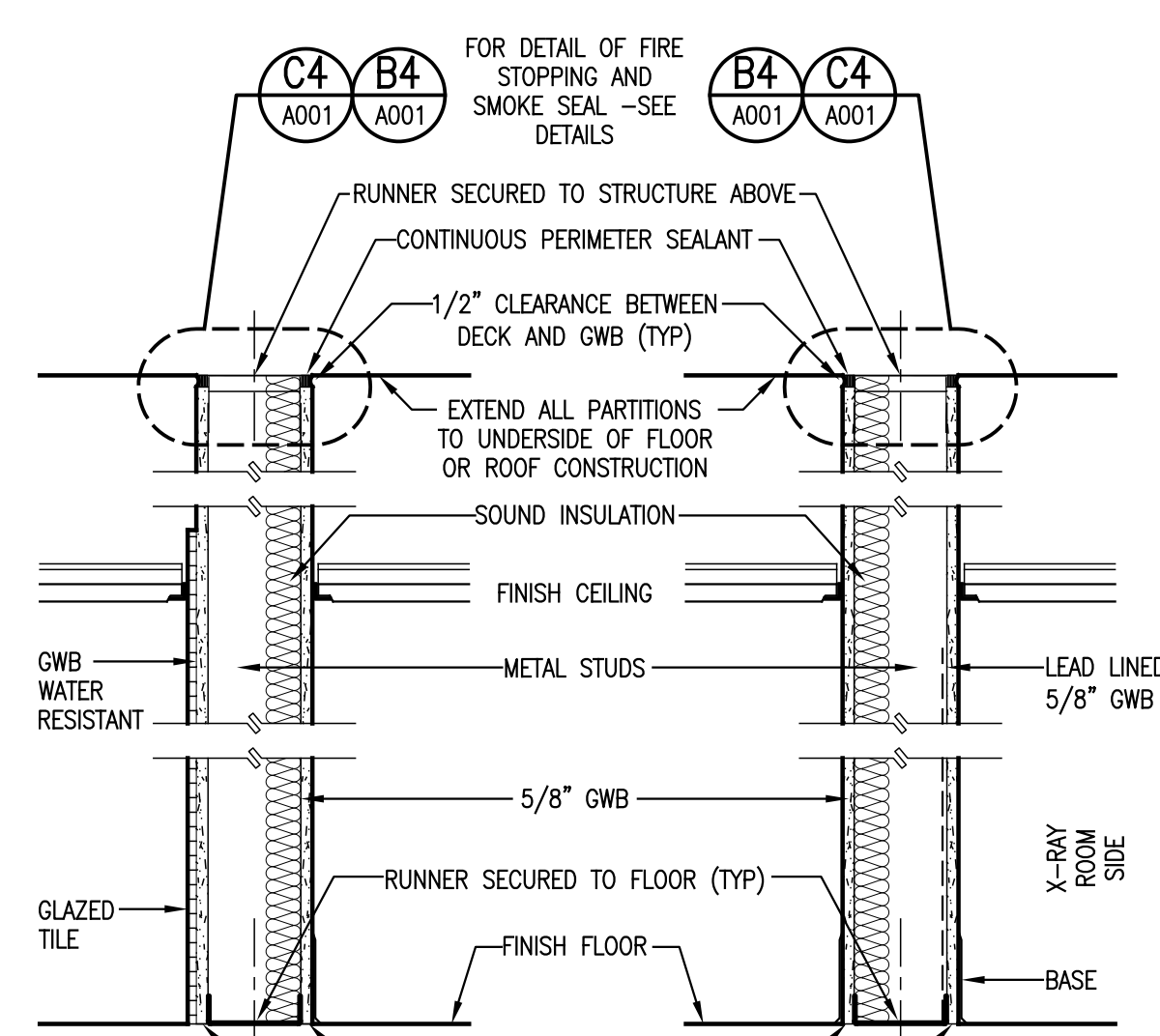

- TYPE (D3) NON-RATED
(STC 45) ONE LAYER 5/8\"/>
- TYPE (D1) NON-RATED
(STC 45) ONE LAYER 5/8\"/>
- TYPE (D2) 1 HR RATED
(STC 45) ONE LAYER 5/8\"/>
- TYPE (D3) 1 HR RATED
(STC 45) ONE LAYER 5/8\"/>

(D3) PARTITION TYPES SCHEDULE
SCALE: 1 1/2\"/>

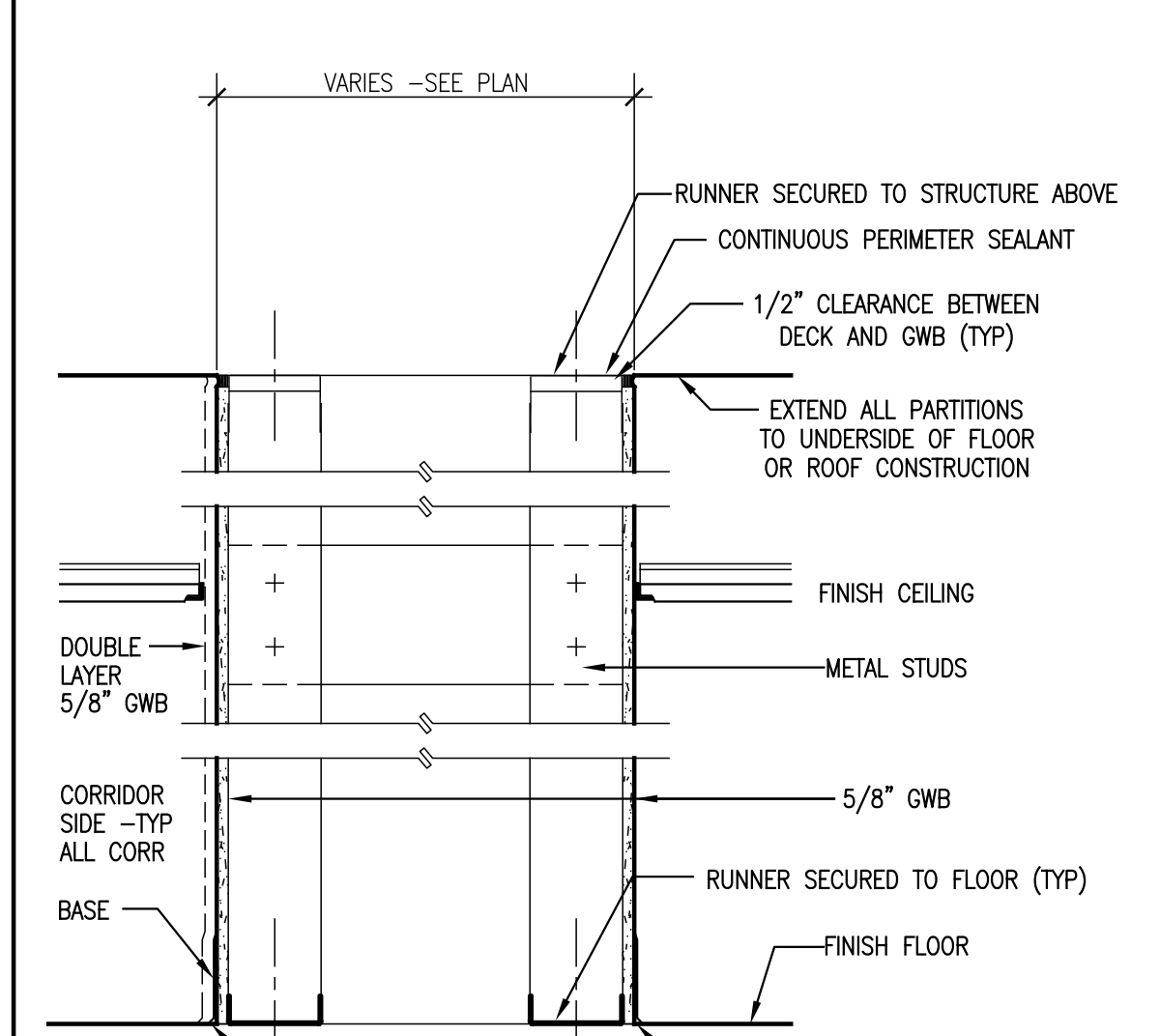

- TYPE (E3) NON-RATED
(STC 45) ONE LAYER 5/8\"/>
- TYPE (E1) NON-RATED
(STC 50) DOUBLE LAYER 5/8\"/>
- TYPE (E2) NON-RATED
(STC 45) ONE LAYER 5/8\"/>

(E3) PARTITION TYPES SCHEDULE
SCALE: 1 1/2\"/>

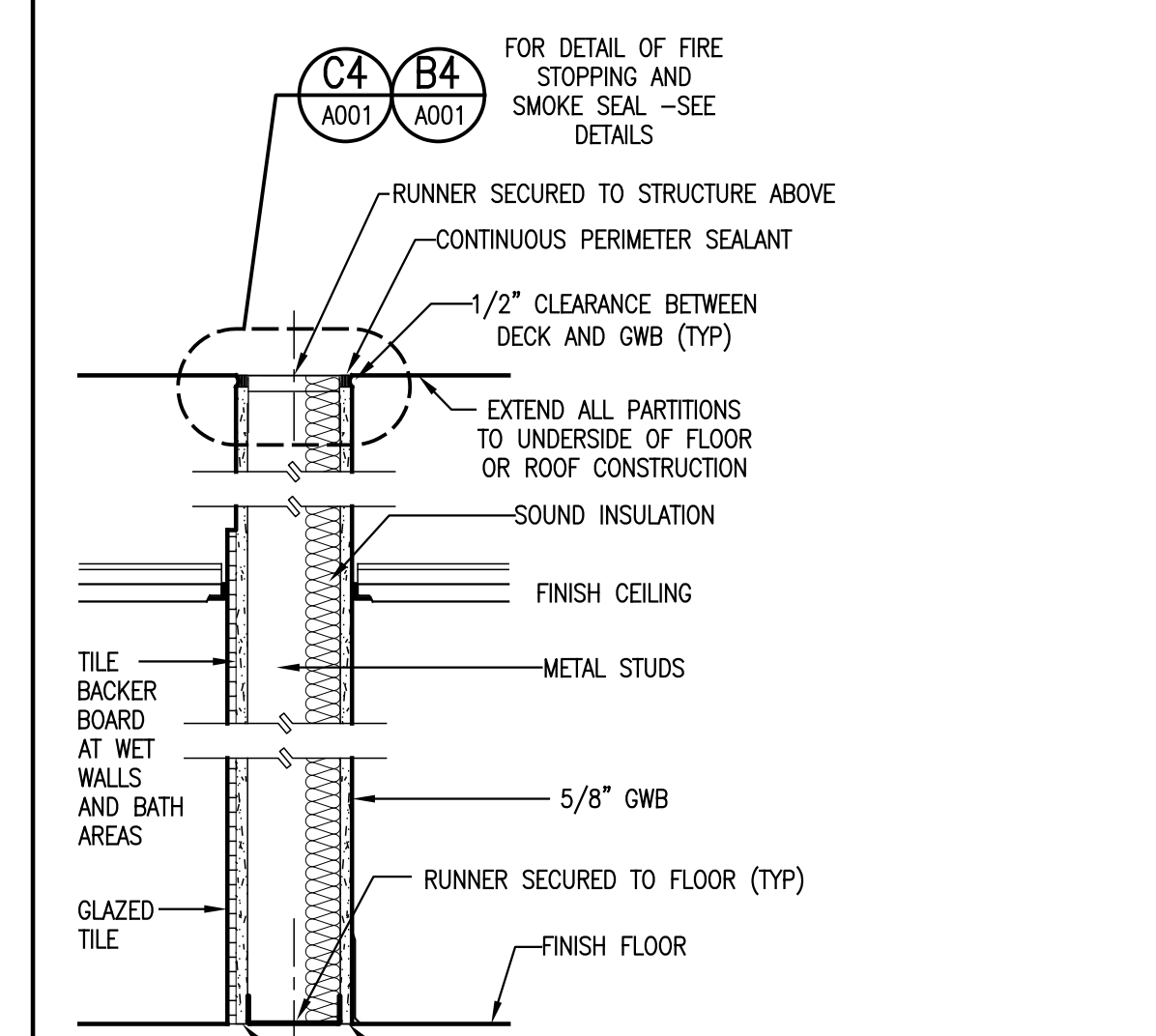

- TYPE (F3) NON-RATED
(STC 45) ONE LAYER 5/8\"/>
- TYPE (F1) NON-RATED
(STC 45) ONE LAYER 5/8\"/>
- TYPE (F2) 1 HR RATED
(STC 45) ONE LAYER 5/8\"/>
- TYPE (F3) 1 HR RATED
(STC 45) ONE LAYER 5/8\"/>

(F3) PARTITION TYPES SCHEDULE
SCALE: 1 1/2\"/>

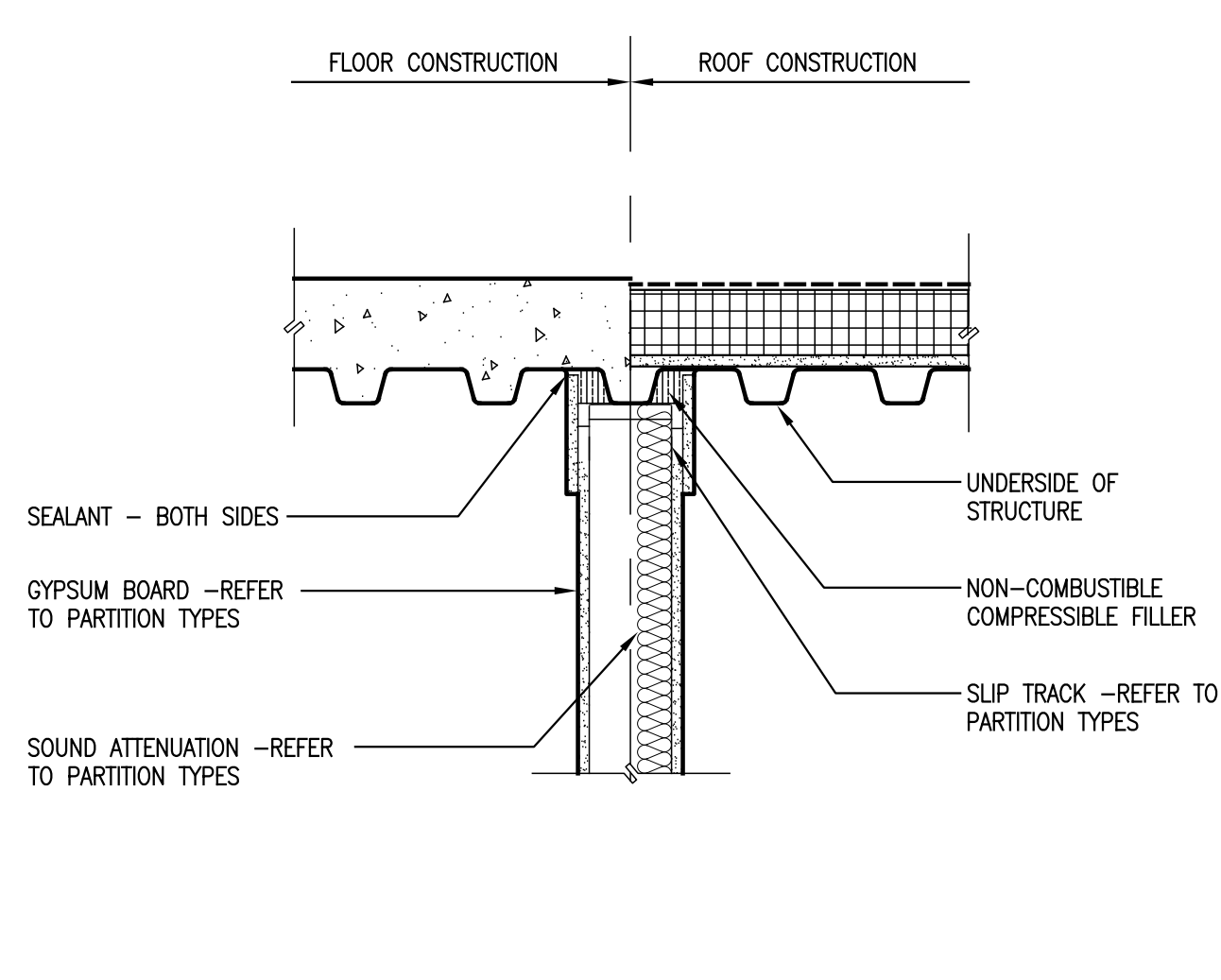

(B4) NON-RATED PARTITION -TOP OF WALL DETAIL
SCALE: 1 1/2\"/>

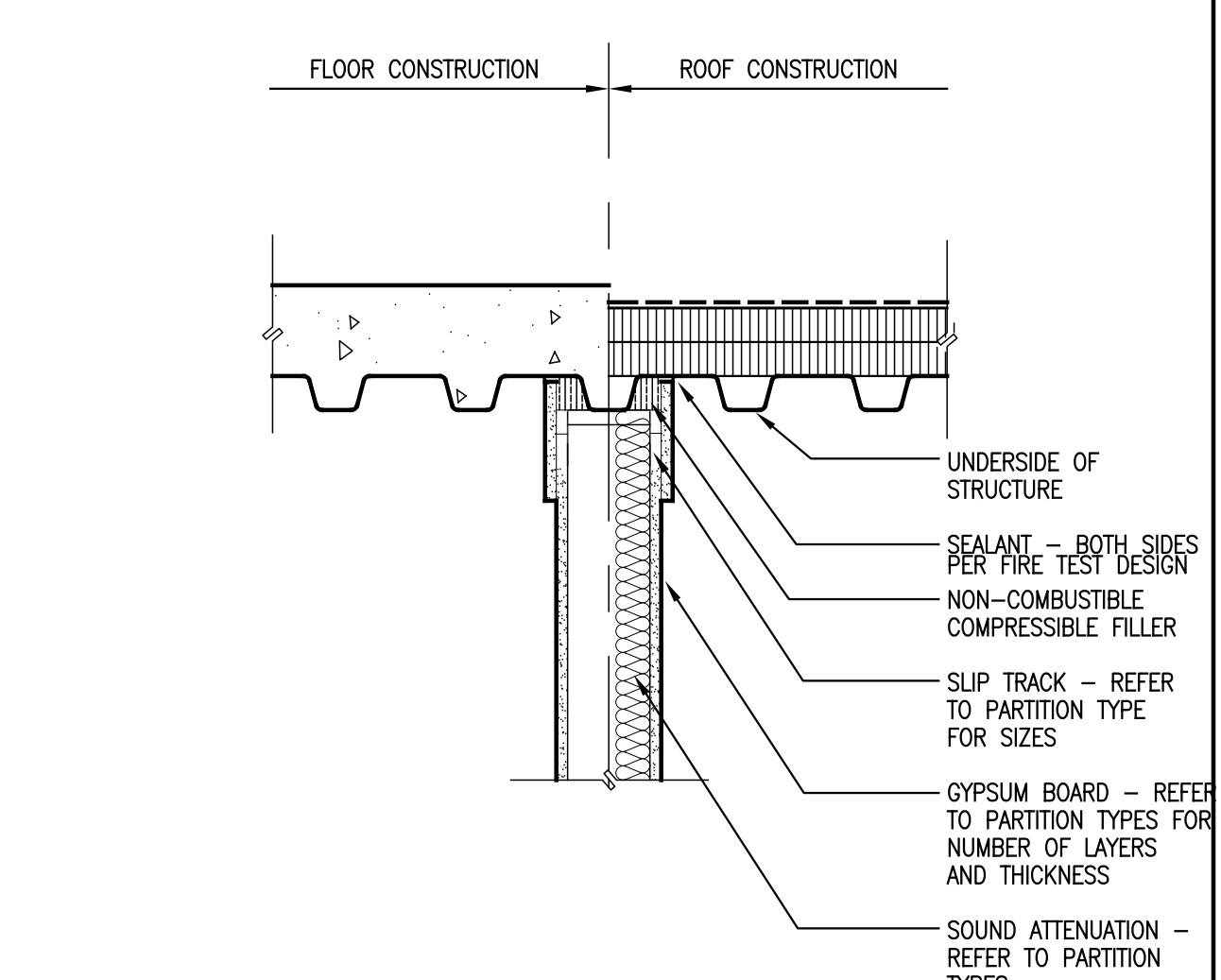

(C4) RATED PARTITION -TOP OF WALL DETAIL
SCALE: 1 1/2\"/>

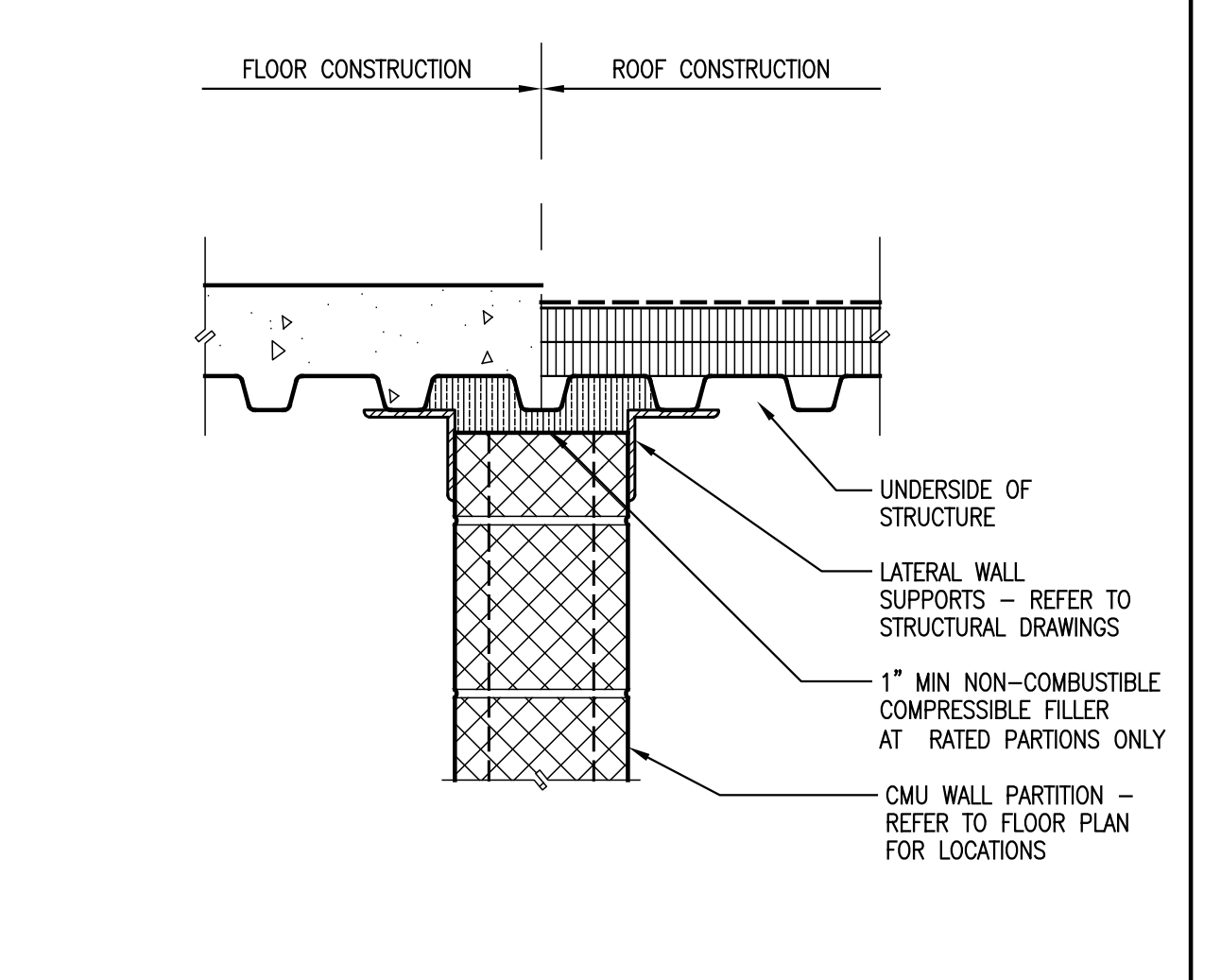

(D4) CMU PARTITION -TOP OF WALL DETAIL
SCALE: 1 1/2\"/>

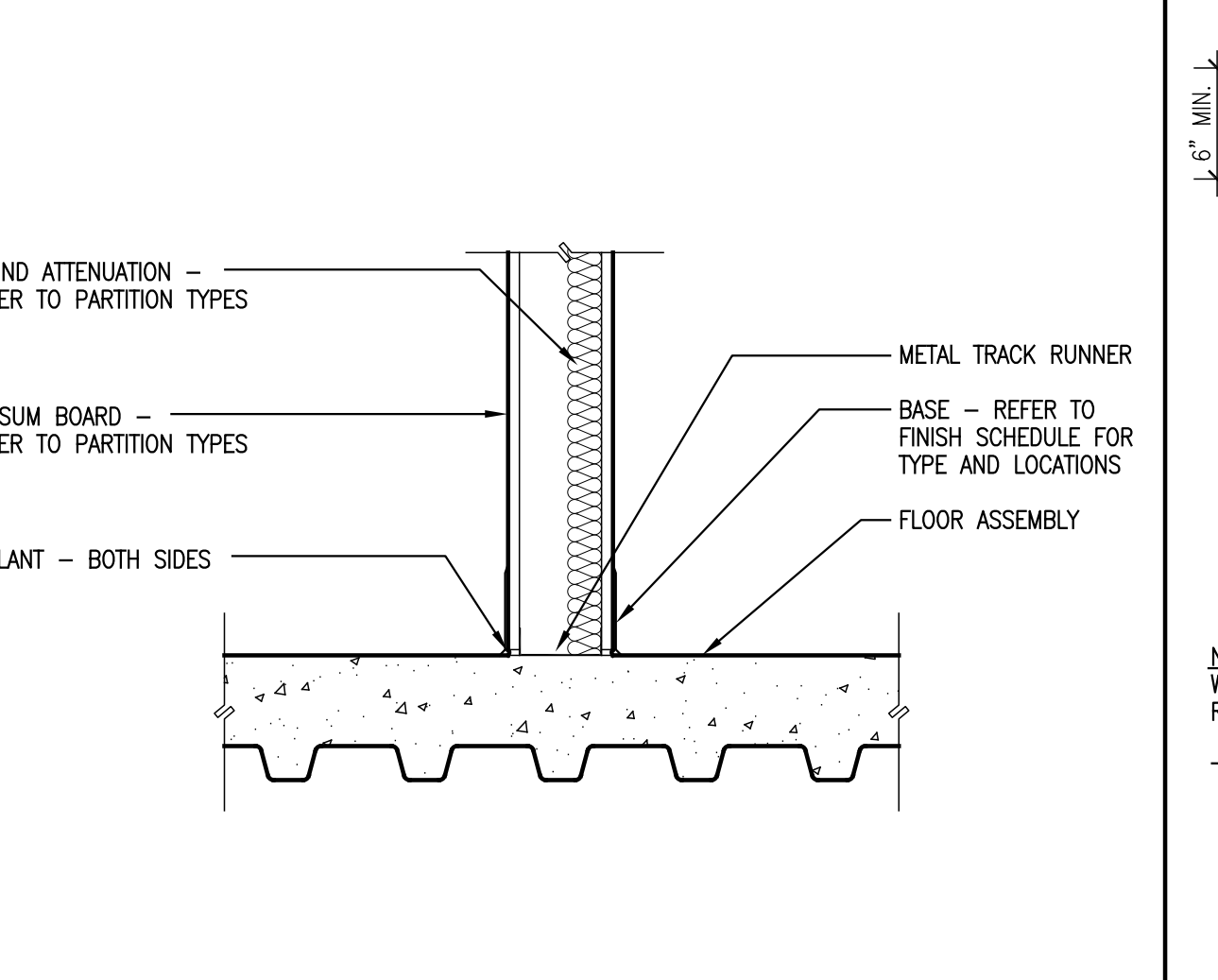

(E4) BOTTOM OF WALL DETAIL
SCALE: 1 1/2\"/>

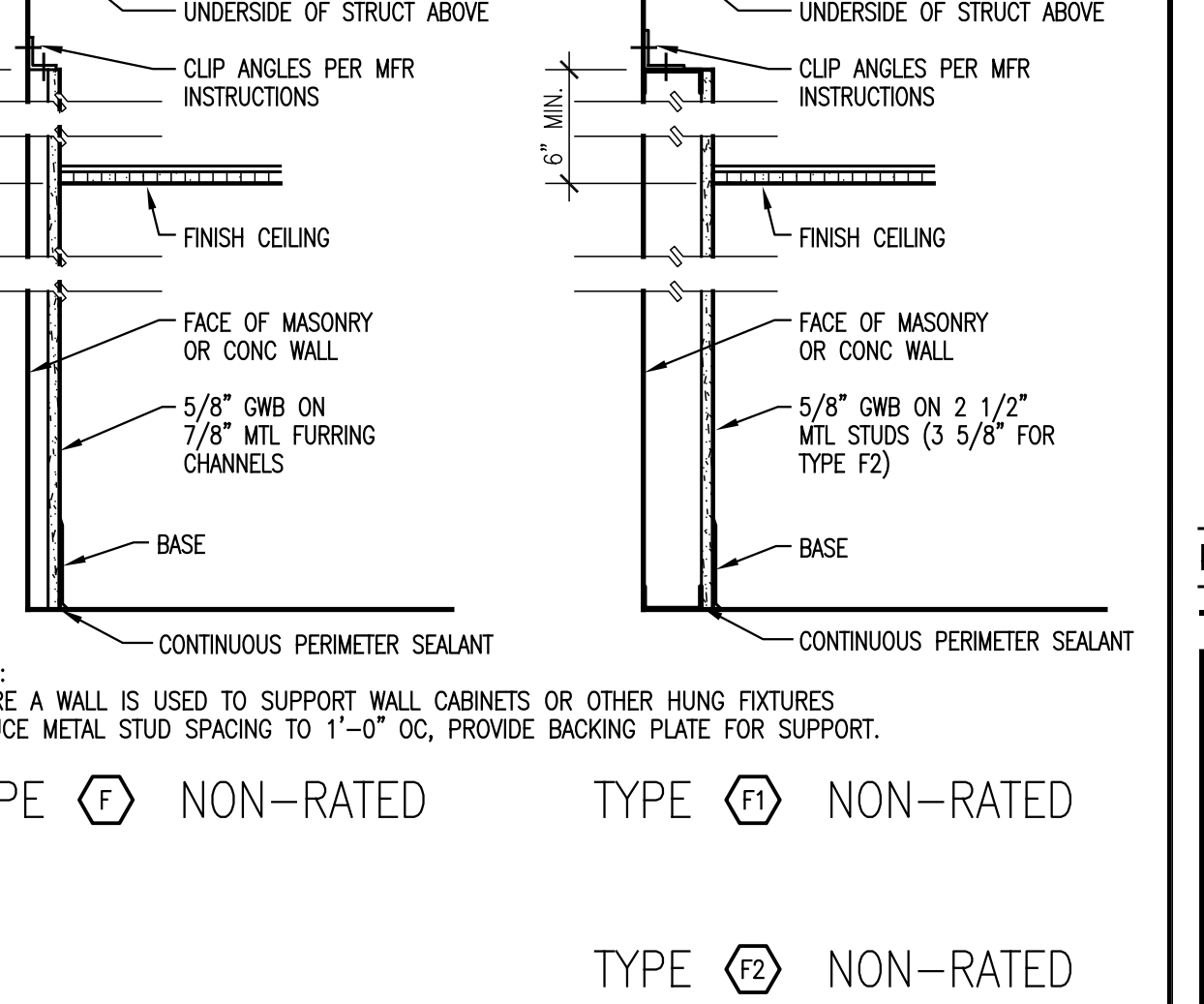

(F4) WALL FURRING TYPES F, F1, AND F2
SCALE: 1 1/2\"/>

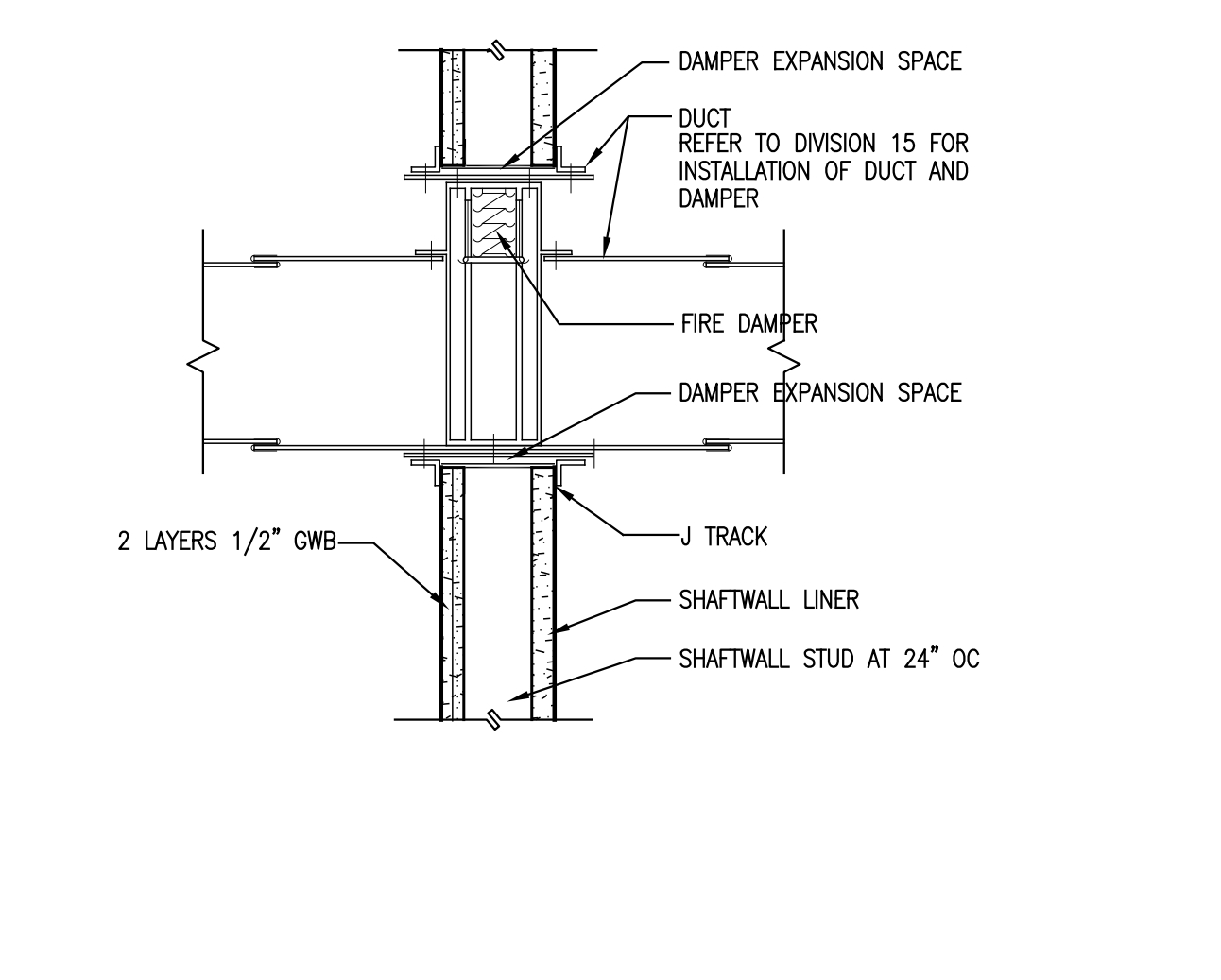

SECTION A
(B5) DUCT OPENING INTO 2-HOUR SHAFT WALL
SCALE: 1 1/2\"/>

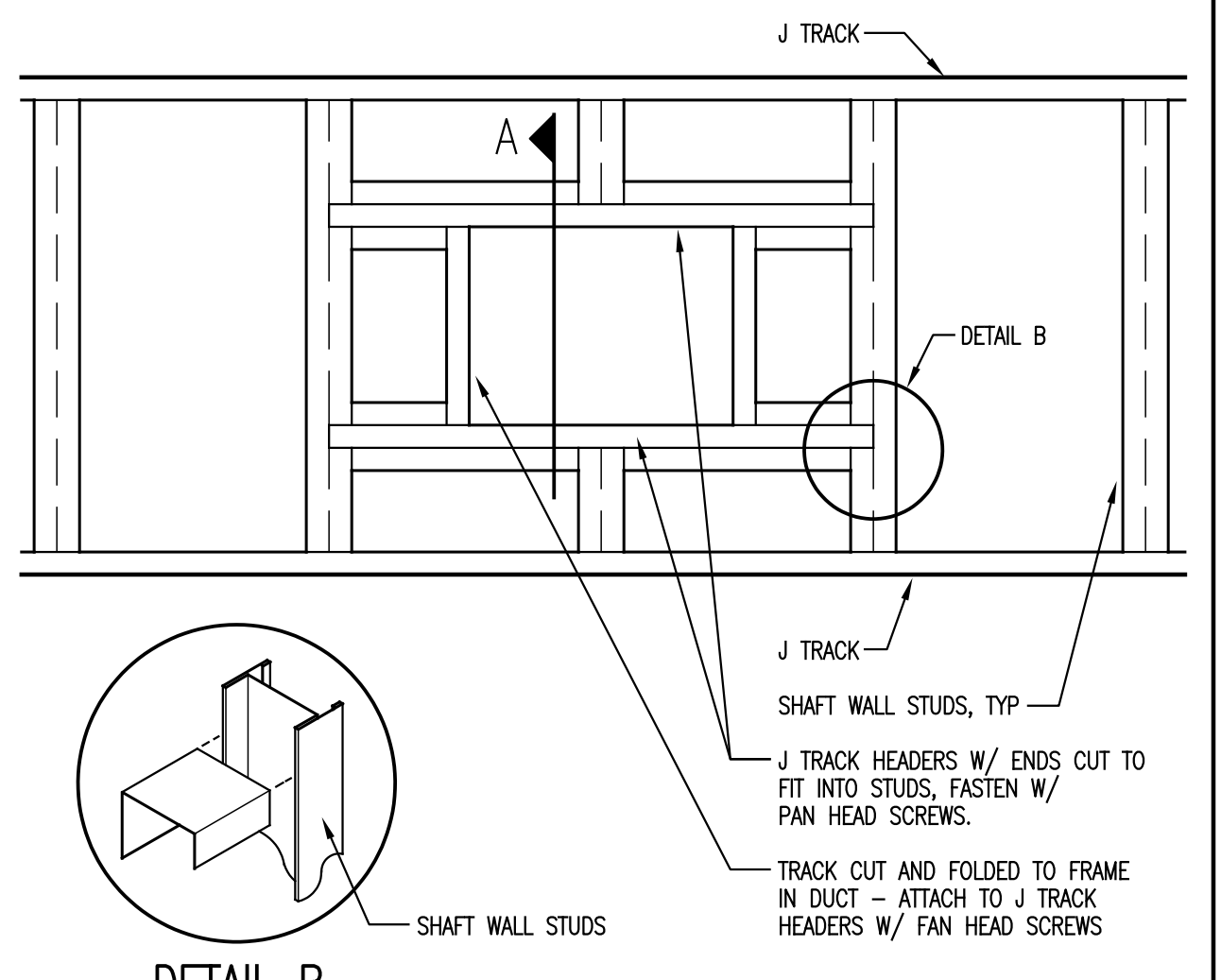

(C5) DUCT OPENING INTO 2-HOUR SHAFT WALL
SCALE: 1 1/2\"/>

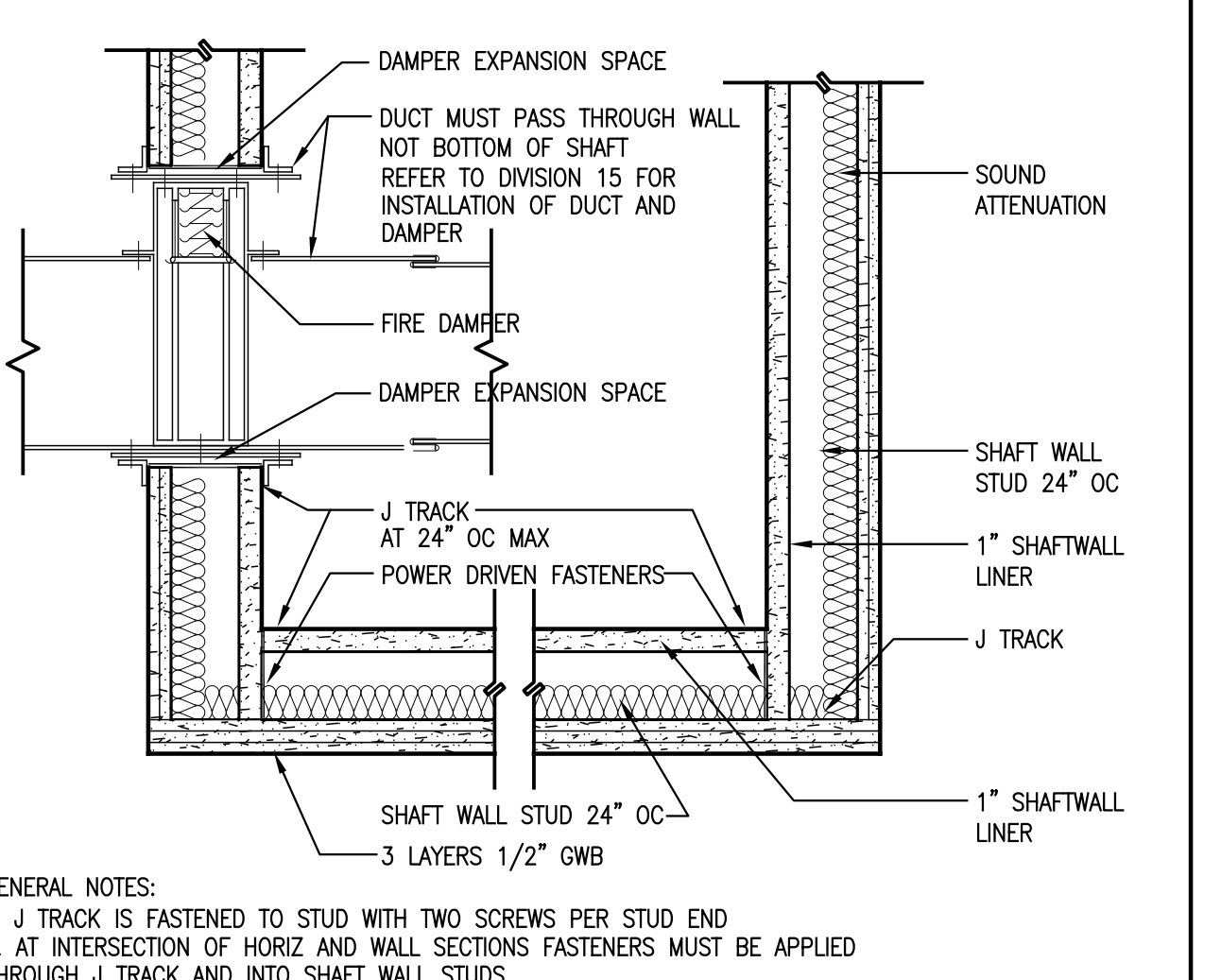

GENERAL NOTES:
1. J TRACK IS FASTENED TO STUD WITH TWO SCREWS PER STUD END
2. AT INTERSECTION OF HORIZ AND WALL SECTIONS FASTENERS MUST BE APPLIED THROUGH J TRACK AND INTO SHAFT WALL STUDS
3. FIRE TEST # WH-495 PSH 0154/0167 AT HORIZ CLOSURE
(D5) 2-HOUR HORIZONTAL SHAFT WALL CLOSURE
SCALE: 1 1/2\"/>

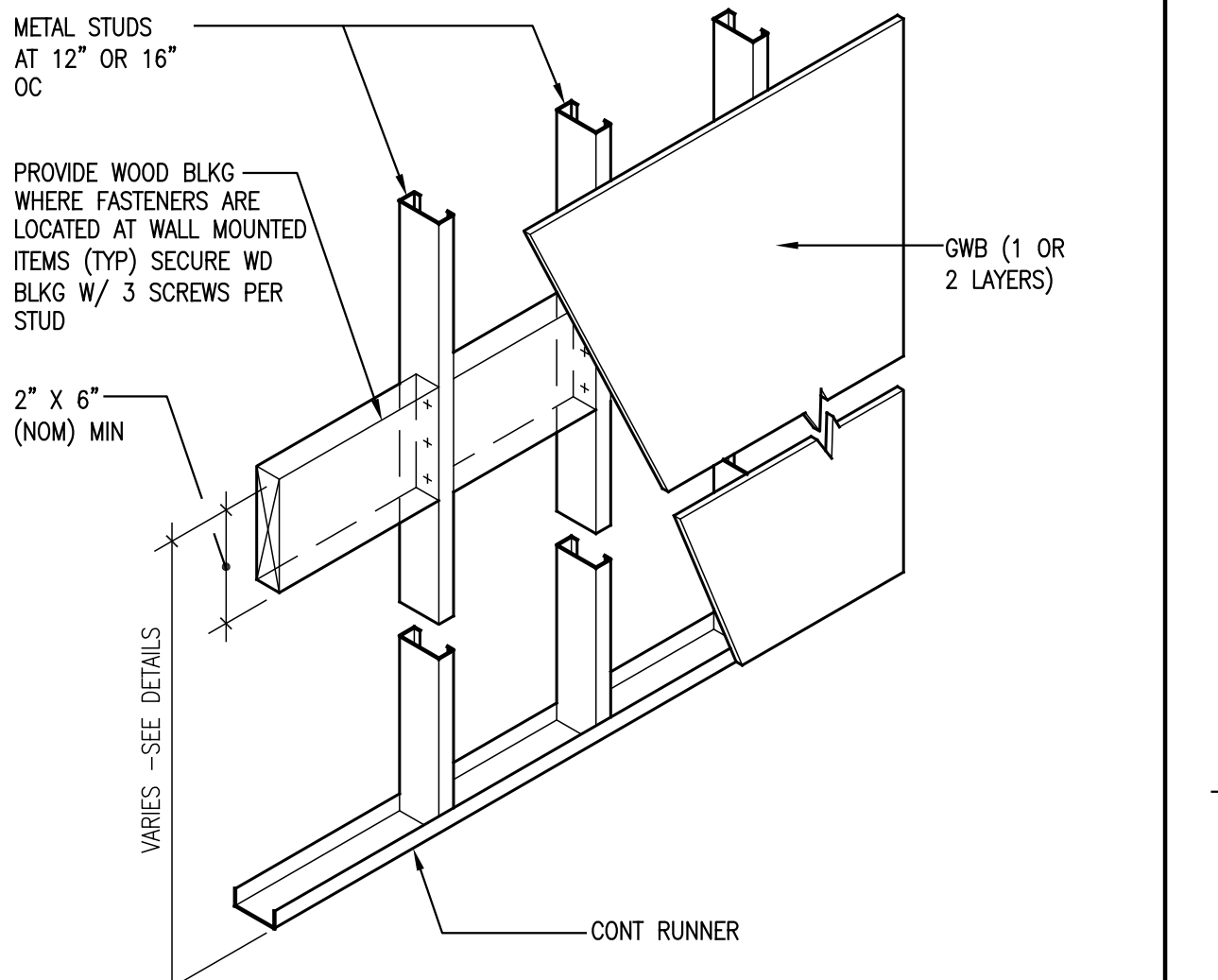

(E5) WOOD BLOCKING ISOMETRIC FOR WALL MOUNTED ITEMS
SCALE: 3/4\"/>

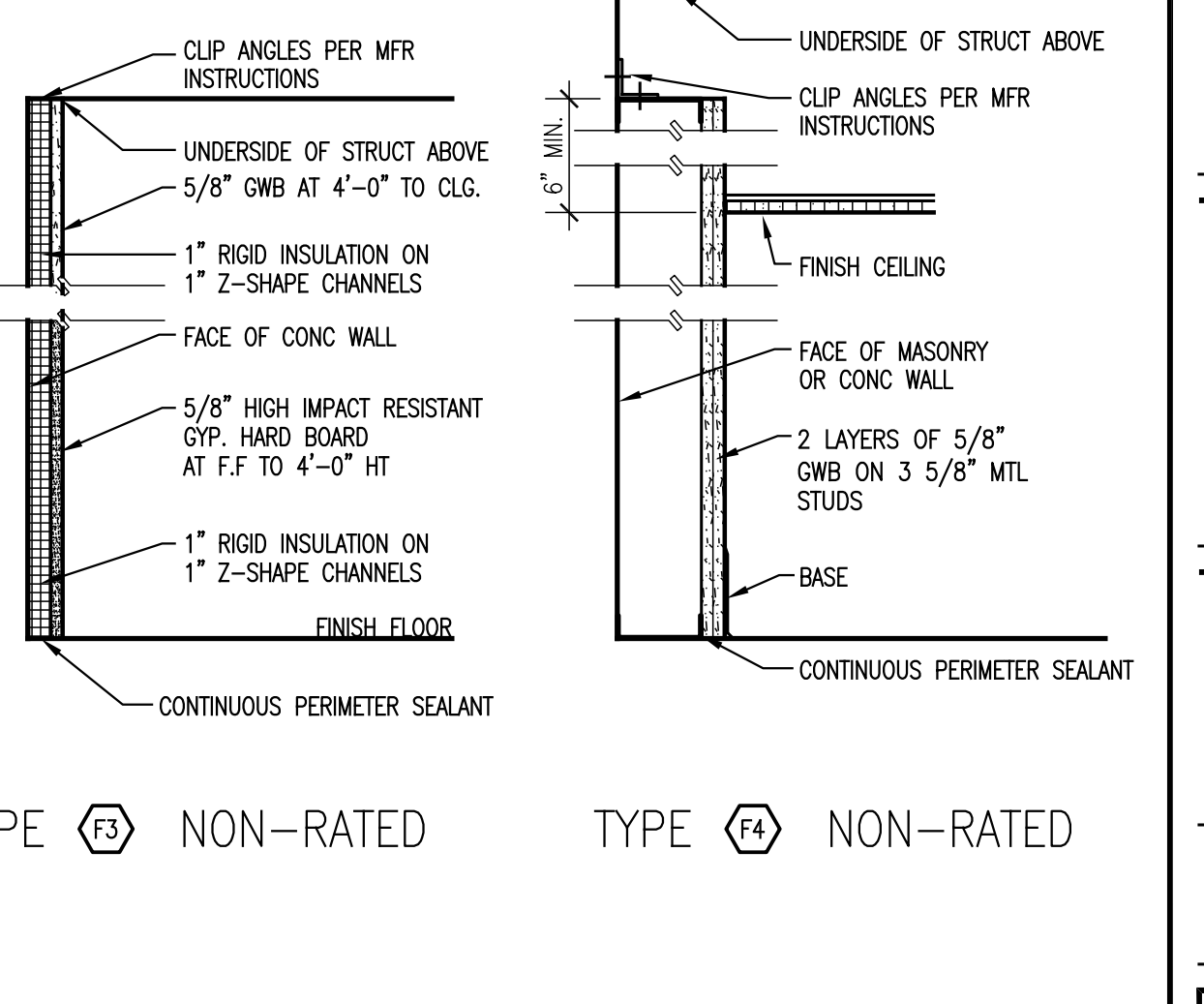

(F5) WALL FURRING TYPES F3
SCALE: 1 1/2\"/>

FOR PERMIT ONLY
NOT FOR CONSTRUCTION

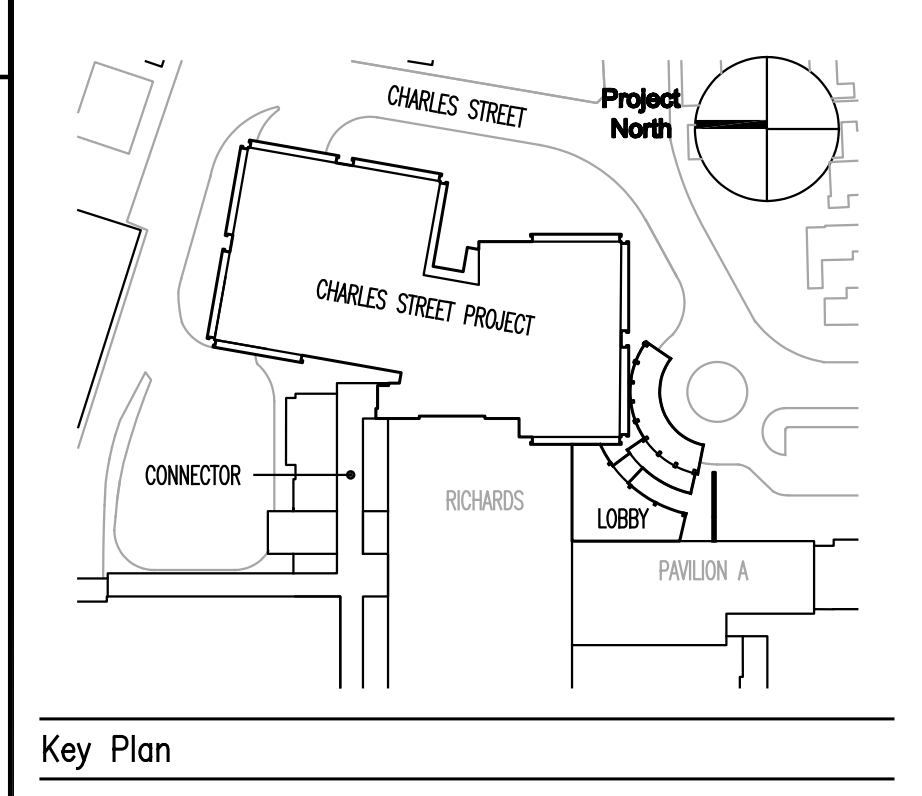

TRO
ARCHITECTURE
PLANNING
ENGINEERING
INTERIOR DESIGN
The Ritchie Organization
80 Bridge Street
Newton, MA 02459-1194
817-999-9100

Maine Medical Center
Charles Street Project
Portland, Maine MMC Project No. 21841

Drawing Title
PARTITION SCHEDULE AND DETAILS

Commission No.	4673	Date Issued	
Scale	AS NOTED	Sheet Number	
Drawn By	JAV		
Approved By	RA		
Filename	3/16/11/11_4673A001.dwg		
Copyright	© 2011 The Ritchie Organization		

A001