

PORTLAND

MAINE MEDICAL CENTER OFF-SITE IMPROVEMENTS

FOR:
 MAINE MEDICAL CENTER
 22 BRAMHALL STREET
 PORTLAND, MAINE 04102

IN CONJUNCTION WITH:
 PERKINS + WILL
 225 FRANKLIN STREET - SUITE 1100
 BOSTON, MA 02110

ENGINEER / SURVEYOR:

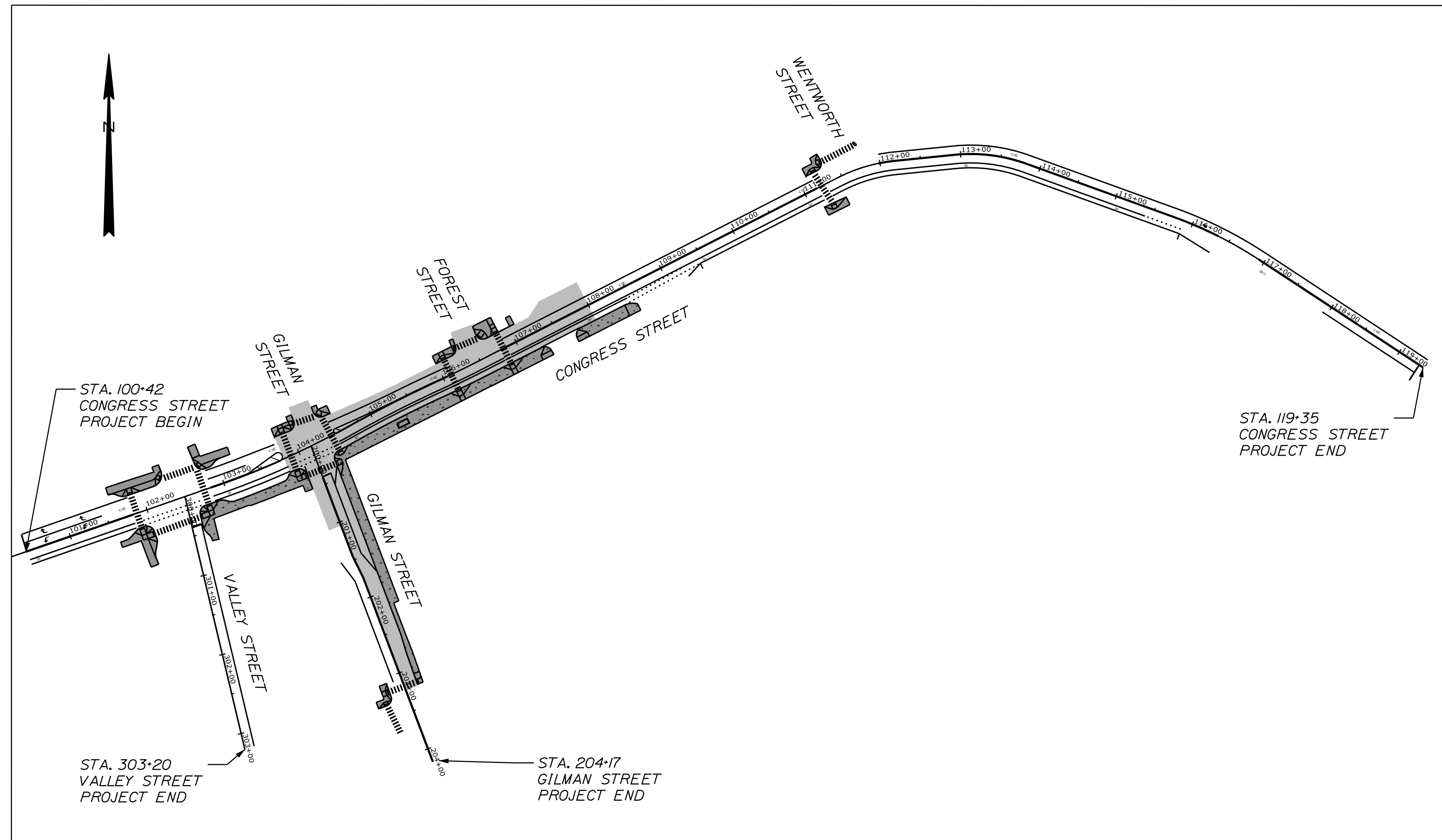

SCALE: 1"=100'

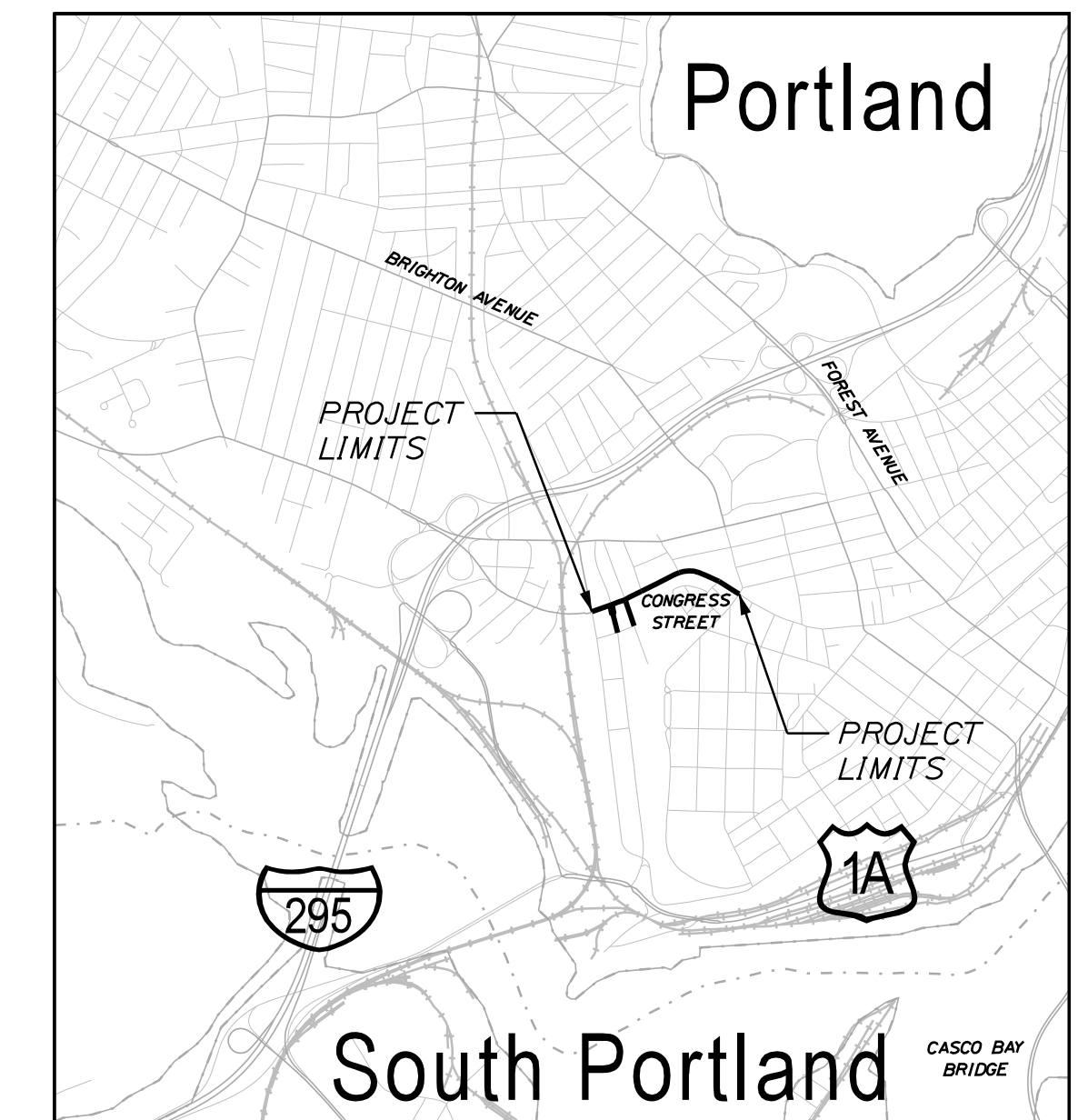

LOCATION MAP

PLAN LEGEND

Town, County, State	Centerline-Existing	Centerline-Proposed
Property Lines	Travelway-Existing	Travelway-Proposed
R/W Lines-Existing	Railroad	Catch Basins
R/W Lines-Proposed	Culvert-Existing	Manholes
Culvert Proposed	Culvert Proposed	Proposed Underdrain
Curbing Existing	Curbing Proposed	Proposed Ditch
Type 1	Type 3	Existing Ditch
Type 3	Type 5	Utility Poles
Outline of Bodies of Water	Boring	Fire Hydrants
	Pavement Core	Existing Water Line
	Test Pit	Existing San. Sewer
	Probe	Existing San. Sewer Manhole
		Guardrail-Existing
		Guardrail-Proposed
		Guardrail-Cable, Other
		Exposed Bedrock
		Buildings
		Trees
		Tree Line
		Clearing Limit Line

#, # = Depth
 X = W (Weathered Rock)
 R (Refusal)
 NR (No Refusal)

SHEET INDEX:

SHEET	DESCRIPTION
1	TITLE SHEET
2	GENERAL NOTES, TYPICALS, & DETAILS
3	GEOMETRIC PLAN
4-6	GENERAL PLANS AND PROFILES
7-11	CURB PLANS
12-15	PAVEMENT MARKING & SIGNING PLANS
16	TRAFFIC SIGNAL PLAN

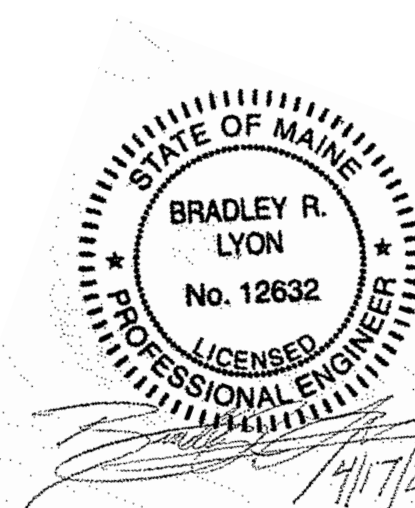

100% FINAL CONTRACT PLANS
APRIL 17, 2020

GENERAL NOTES

- ALL WORK UNDER THIS CONTRACT TO BE GOVERNED BY THE CITY OF PORTLAND'S TECHNICAL MANUAL AND SUPPLEMENTED WITH THE LATEST REVISION AND UPDATES OF THE STATE OF MAINE, DEPARTMENT OF TRANSPORTATION, STANDARD SPECIFICATIONS, REVISION OF 2014 AND STANDARD DETAILS REVISION OF 2014 WITH THE LATEST REVISION AND UPDATES.
 - MAINTENANCE OF TRAFFIC SHALL BE PER THE MANUAL OF UNIFORM TRAFFIC CONTROL DEVICES, (MUTCD), LATEST EDITION.
 - ALL WORK SHALL BE DONE IN ACCORDANCE WITH THE MAINE DEPARTMENT OF TRANSPORTATION'S BEST MANAGEMENT PRACTICES FOR EROSION CONTROL & SEDIMENT CONTROL, FEBRUARY, 2008.
 - THE CONTRACTOR IS SPECIFICALLY CAUTIONED THAT EXISTING UTILITY LOCATIONS AND/OR ELEVATIONS ARE APPROXIMATE. THE CONTRACTOR IS HEREBY CAUTIONED THAT ALL EXISTING SUBSURFACE LINES AND STRUCTURES MAY NOT BE SHOWN. THE INFORMATION IS NOT TO BE RELIED ON AS BEING EXACT OR COMPLETE. THE CONTRACTOR SHALL CONTACT DIG SAFE AT LEAST THREE (3) BUT NOT MORE THAN THIRTY (30) DAYS PRIOR TO COMMENCEMENT OF EXCAVATION OR DEMOLITION. THE CONTRACTOR SHALL BE RESPONSIBLE FOR COMPLIANCE WITH THE REQUIREMENTS OF THE MAINE "DIG SAFE LAW" CHAPTER 718, ENACTED ON 8-11-00. CONTRACTOR SHALL TAKE NOTICE OF THE FOLLOWING RULES:
 - ENFORCEMENT - THE ADMINISTRATIVE PENALTY FOR VIOLATION OF MAINE DIG SAFE LAW IS AS FOLLOWS:
FIRST OFFENSE = \$500.00
SUBSEQUENT OFFENCES (WITHIN 12 MONTHS) = \$5,000.00

THE PUC MAY ALSO REQUIRE A PERSON WHO VIOLATES THE MAINE DIG SAFE LAW TO PARTICIPATE, AT THE EXPENSE OF THE VIOLATOR, IN AN EDUCATIONAL PROGRAM DEVELOPED AND CONDUCTED BY DIG SAFE SYSTEM, INC.

 - EXCAVATION METHODS - IF EXCAVATING WITHIN 18 INCHES OF ANY MARKED UNDERGROUND FACILITY, AN EXCAVATOR MAY NOT USE MECHANICAL MEANS OF EXCAVATION (THE USE OF ANY DEVICE OR TOOL POWERED BY AN ENGINE) UNTIL THE UNDERGROUND FACILITY IS EXPOSED.

EXCEPTIONS: THIS RULE DOES NOT APPLY IF USING AIR VACUUM METHODS OF EXCAVATION. MECHANICAL MEANS MAY BE USED FOR INITIAL PENETRATION OR REMOVAL OF PAVEMENT, ROCK OR OTHER MATERIAL REQUIRING MACHINERY.

EMERGENCIES: PREVIOUSLY, AN EXCAVATOR WAS NOT REQUIRED TO NOTIFY DIG SAFE PRIOR TO ANY EMERGENCY EXCAVATION. NOW IN AN EMERGENCY SITUATION, AN EXCAVATOR MAY COMMENCE EXCAVATION AFTER HAVING TAKEN ALL REASONABLE STEPS CONSISTENT WITH THE EMERGENCY AND PREMARK THE AREA AS SOON AS POSSIBLE AFTER RECEIVING NOTIFICATION OF THE EMERGENCY.
- PAVEMENT THICKNESSES SHOWN ON THE TYPICAL SECTIONS ARE INTENDED TO BE NOMINAL.
 - ALL JOINTS BETWEEN EXISTING AND PROPOSED HOT BITUMINOUS PAVEMENT SHALL BE BUTTED. BUTT JOINTS SHALL HAVE A MINIMUM WIDTH OF 18 INCHES.
 - GRIND TRANSITION TAPERS AT CATCH BASINS UNDER STANDARD SPECIFICATIONS ITEM 202.203. PAVEMENT BUTT JOINTS IN ACCORDANCE WITH STANDARD DETAIL 609(05). GUTTER GRADE TRANSITION AT CATCH BASIN.
 - ANY NECESSARY CLEANING OF EXISTING PAVEMENT PRIOR TO PAVING (OR MILLING) SHALL BE INCIDENTAL TO THE RELATED PAVING (OR MILLING) ITEMS. THIS INCLUDES KILLING AND REMOVAL OF ALL VEGETATIVE MATTER.
 - NO EXISTING DRAINAGE SHALL BE ABANDONED, REMOVED OR PLUGGED WITHOUT PRIOR APPROVAL OF THE RESIDENT.
 - EXISTING ABANDONED WATER MAINS BROKEN BY THE CONTRACTOR DURING CONSTRUCTION SHALL HAVE THE ENDS PLUGGED WITH BRICK AND MORTAR.
 - LOAM HAS BEEN ESTIMATED FOR DISTURBED LAWN AREAS. ACTUAL PLACEMENT OF THE LOAM SHALL BE AS NOTED ON THE PLANS OR DESIGNATED BY THE RESIDENT.
 - UNLESS OTHERWISE NOTED SEEDING METHOD NO. 1 SHALL BE UTILIZED ON ALL LAWNS AND DEVELOPED AREAS; SEEDING METHOD NO. 2 SHALL BE UTILIZED ON ALL OTHER AREAS.
 - LOAM SHALL BE PLACED TO A NOMINAL DEPTH OF 4 INCHES IN LAWN AREAS AND 2 INCHES IN ALL OTHER AREAS UNLESS OTHERWISE NOTED OR DIRECTED.
 - STATIONS REFERENCED ARE APPROXIMATE.
 - FINAL STRIPING FOR THE PROJECT SHALL BE DONE BY THE CONTRACTOR PER THE STRIPING LAYOUT IN THE CONTRACT DOCUMENTS.
 - ALL HMA FOR PATCHING AROUND ADJUSTED, ALTERED, OR REBUILT UTILITY STRUCTURES SHALL BE A 9.5 MM OR 12.5 MM MAINEDOT APPROVED MIX DESIGN. EXCLUDING WATER AND GAS GATE VALVES, THE CONTRACTOR SHALL SAW CUT THE EXISTING PAVEMENT FOR THE PATCH AT LEAST TWO FEET AWAY FROM THE NEAREST EDGE OF THE STRUCTURE. THE CONTRACTOR SHALL PLACE HMA IN LIFTS OF 2 INCHES OR LESS, AS DIRECTED BY THE RESIDENT, AND COMPACT THE HMA USING A MINIMUM OF A 150-POUND PLATE COMPACTOR. HMA FOR PATCHING AROUND ADJUSTED, ALTERED, OR REBUILT UTILITY STRUCTURES IS CONSIDERED INCIDENTAL TO THE RESPECTIVE PAY ITEM FOR ADJUST, ALTER, OR REBUILD UTILITY STRUCTURE.

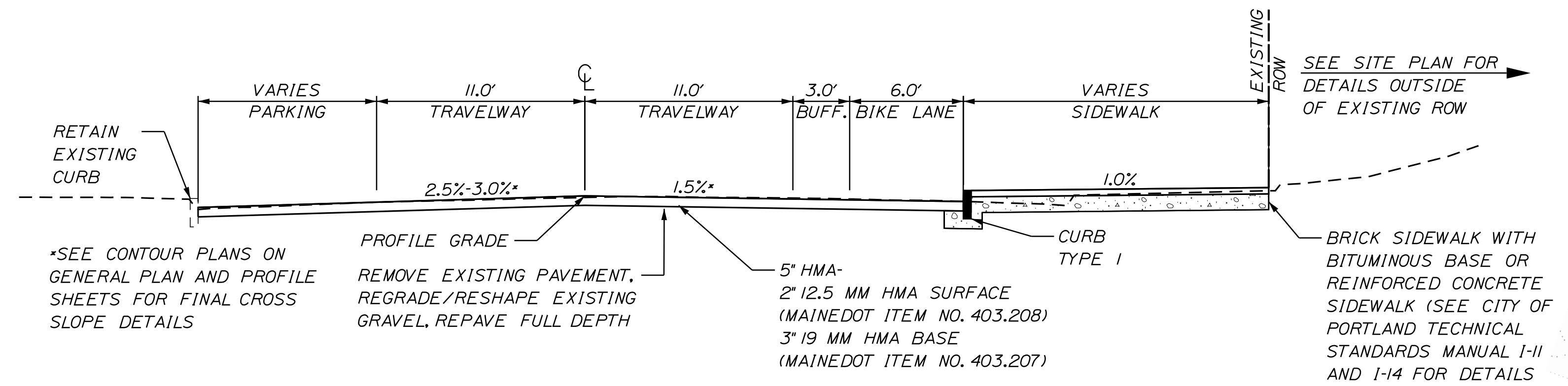

CONGRESS STREET FULL DEPTH PAVEMENT REPLACEMENT
STA. 103+80 TO STA. 108+00

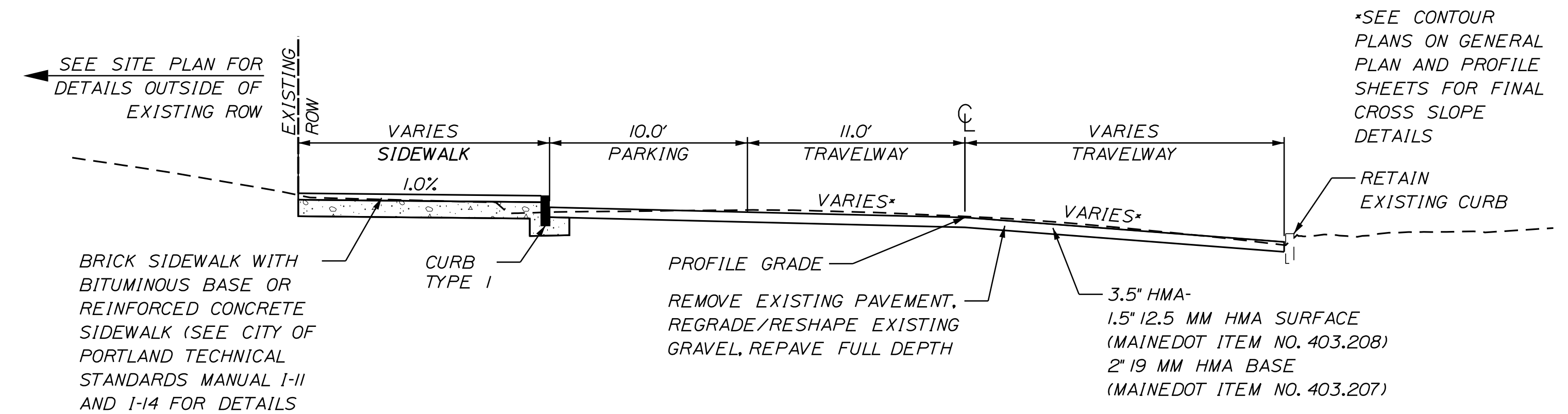

GILMAN STREET FULL DEPTH PAVEMENT REPLACEMENT FULL WIDTH
STA. 200+18 TO STA. 201+05

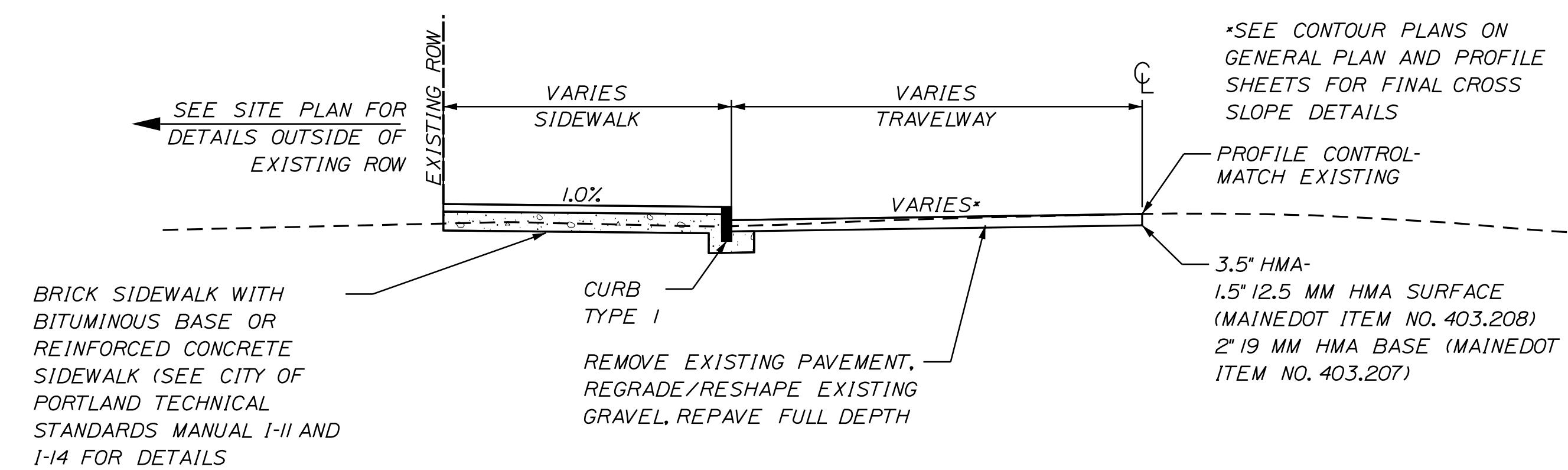

GILMAN STREET FULL DEPTH PAVEMENT REPLACEMENT LT ONLY
STA. 201+05 TO STA. 203+23

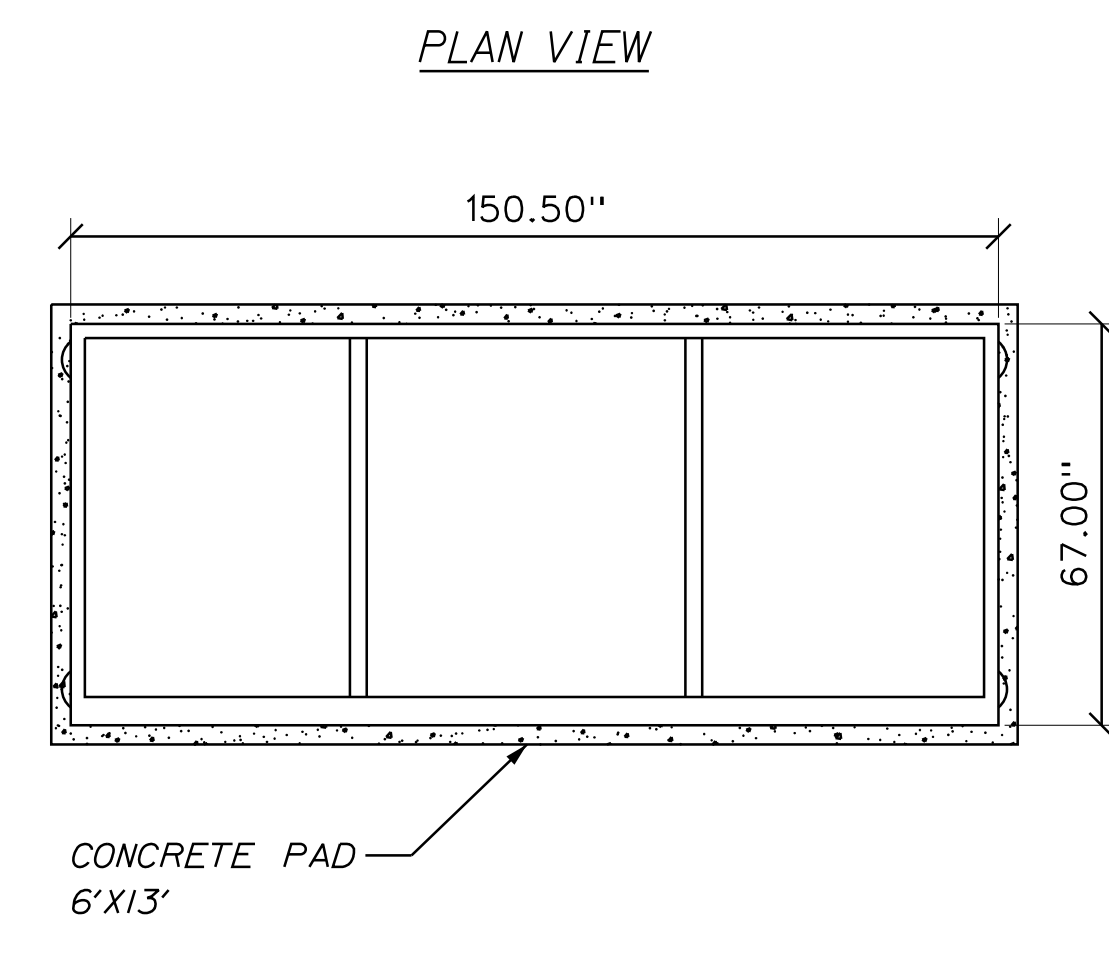
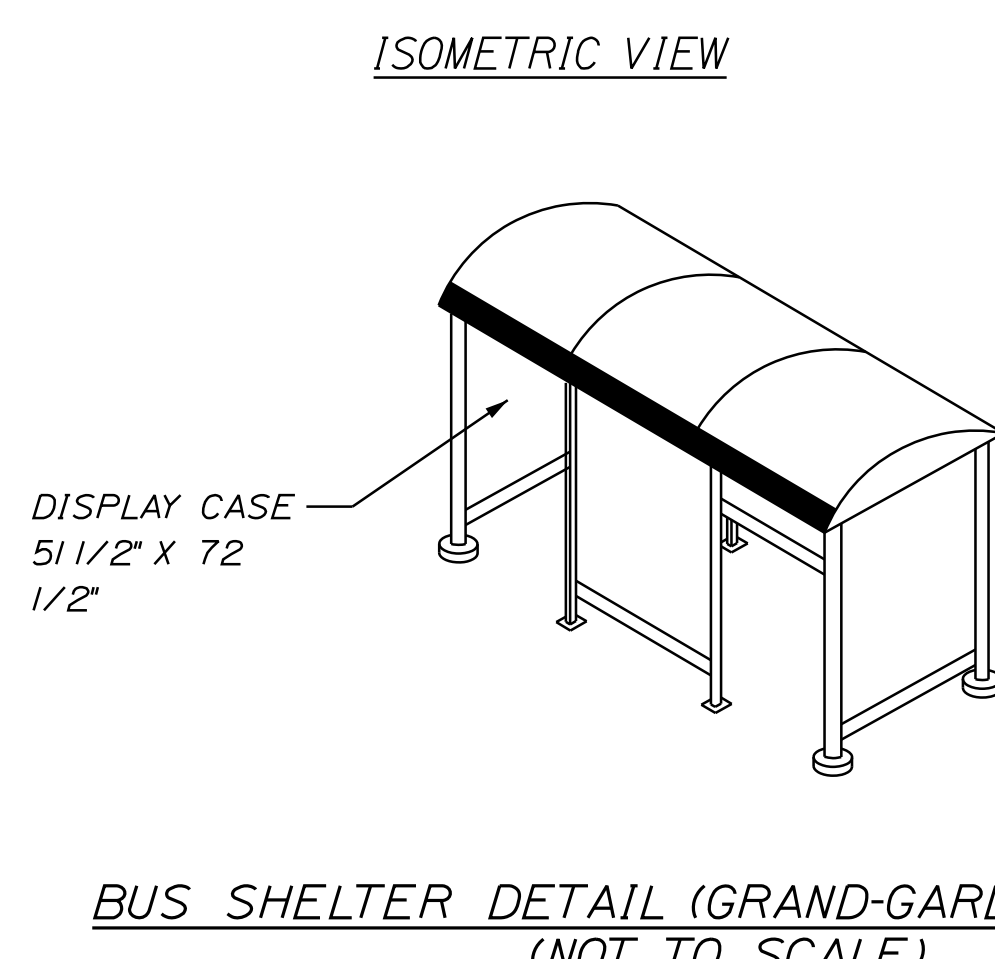
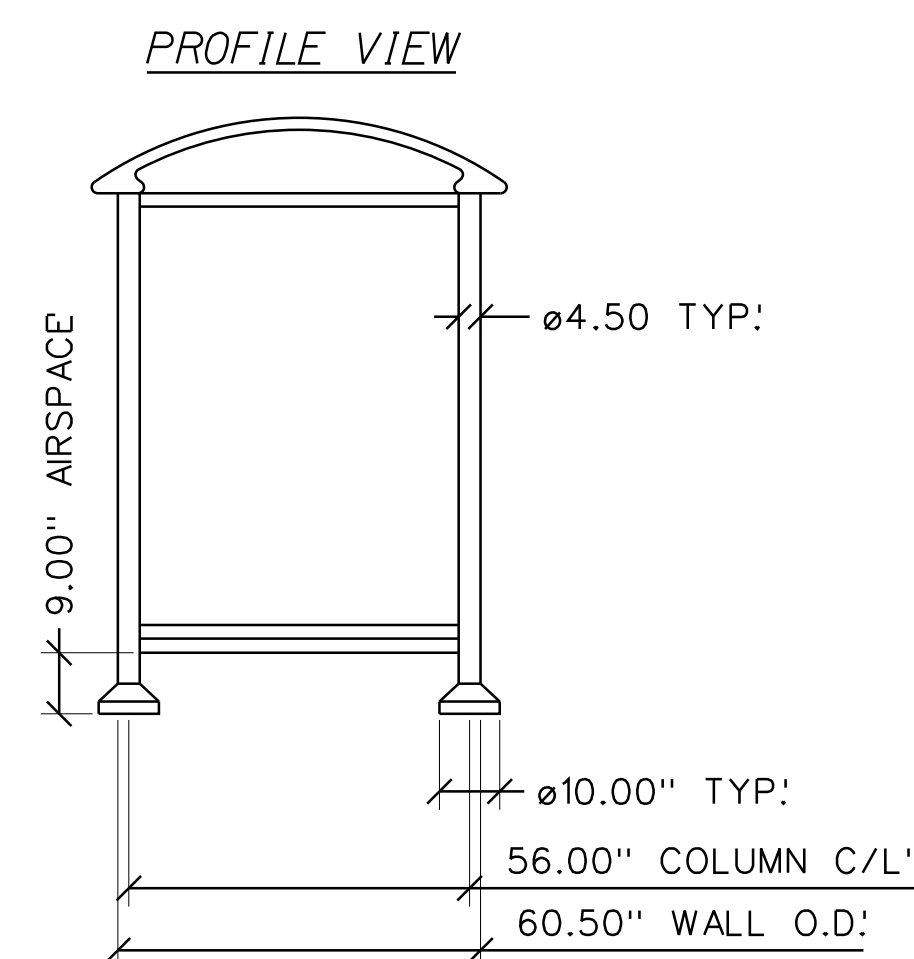
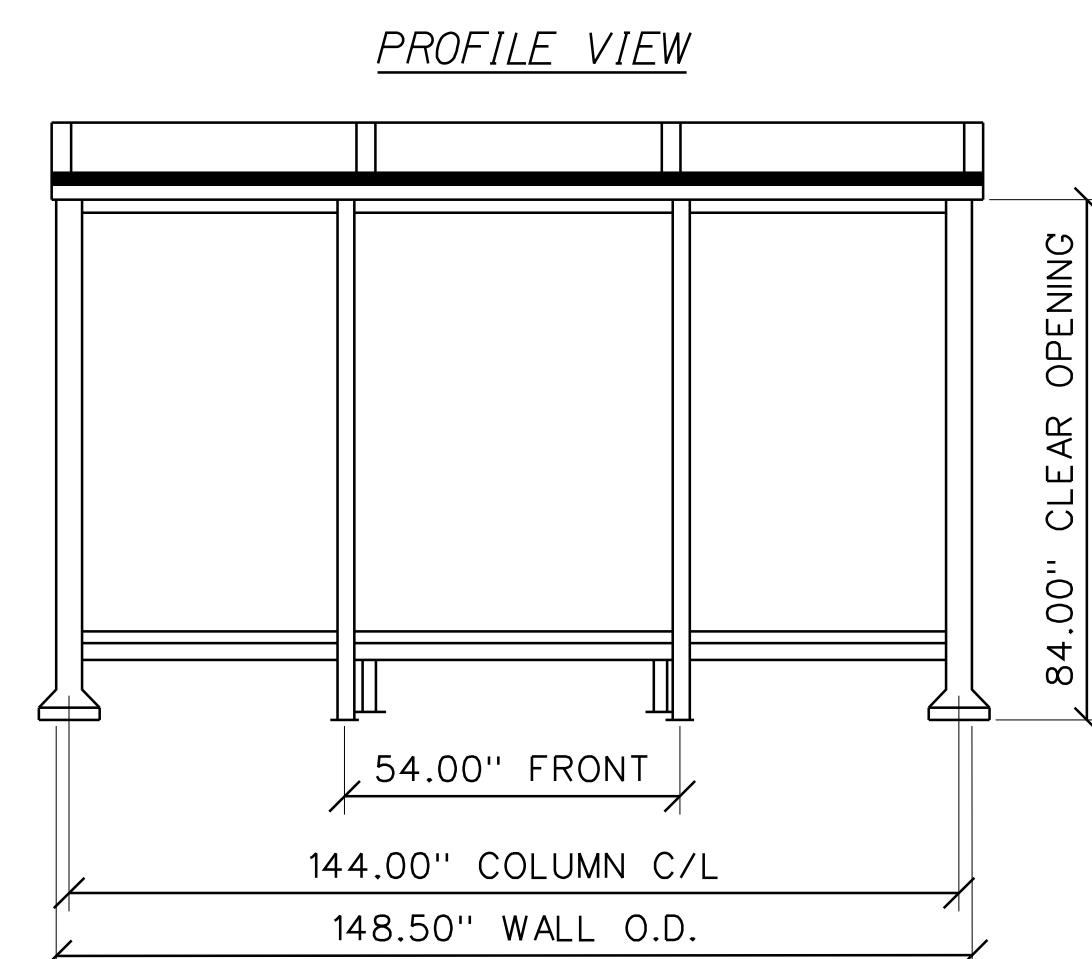

- SHELTER NOTES:**
- BLACK ANODIZED FINISH
 - 3/8" CLEAR TEMPERED GLASS
 - 10MM BRONZE POLYCARBONATE ROOF PANELS (PCSS)
 - DISPLAY CASE - FULL LEFT WALL
 - (2) 5 WATT LED PUCK LIGHTS MOUNTED IN ROOF
 - 44" FREE STANDING ALUMINUM BENCH AND BACKREST

PLS OR PE

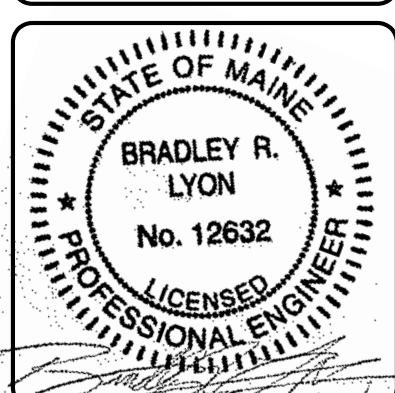

DESIGNED	CHECKED
NLS	BRL
REV. BY:	DATE:
1 NLS	04/17/20
100% FINAL CONTRACT PLANS	
STATUS: FINAL	
THIS PLAN SHALL NOT BE MODIFIED WITHOUT WRITTEN PERMISSION FROM SEBAGO TECHNICS, INC. ANY ALTERATIONS AUTHORIZED OR OTHERWISE, SHALL BE AT THE USER'S SOLE RISK AND WITHOUT LIABILITY TO SEBAGO TECHNICS, INC.	

SEBAGO TECHNICS
WWW.SEBAGOTECHNICS.COM
75 John Roberts Rd.
Suite 4
South Portland, ME 04106
Tel: 207-209-2100

GENERAL NOTES, TYPICALS, & DETAILS
OF:
MAINE MEDICAL CENTER OFF-SITE IMPROVEMENTS
FOR:
MAINE MEDICAL CENTER
22 BRANHALL STREET
PORTLAND, ME 04102

PROJECT NO.	SCALE
15466	1" = 5'



CURVE DATA #1
 PI = 103+80.26
 D = 5°43'46.5"
 Δ = 10°09'36.3" Lt.
 R = 1000.00'
 L = 177.33'
 T = 88.90'
 E = 3.94'

CURVE DATA #2
 PI = 105+28.38
 D = 3°49'11.0"
 Δ = 4°33'29.1" Rt.
 R = 1500.00'
 L = 119.33'
 T = 59.70'
 E = 1.19'

CURVE DATA #3
 PI = 106+18.24
 D = 3°49'11.0"
 Δ = 2°18'31.1" Lt.
 R = 1500.00'
 L = 60.44'
 T = 30.22'
 E = 0.30'

CURVE DATA #4
 PI = 111+82.34
 D = 28°38'52.4"
 Δ = 21°17'43.3" Rt.
 R = 200.00'
 L = 74.33'
 T = 37.60'
 E = 3.50'

CURVE DATA #5
 PI = 113+37.95
 D = 28°38'52.4"
 Δ = 25°38'08.1" Rt.
 R = 200.00'
 L = 89.49'
 T = 45.50'
 E = 5.11'

CURVE DATA #6
 PI = 116+34.74
 D = 11°27'33.0"
 Δ = 13°27'11.0" Rt.
 R = 500.00'
 L = 117.40'
 T = 58.97'
 E = 3.47'

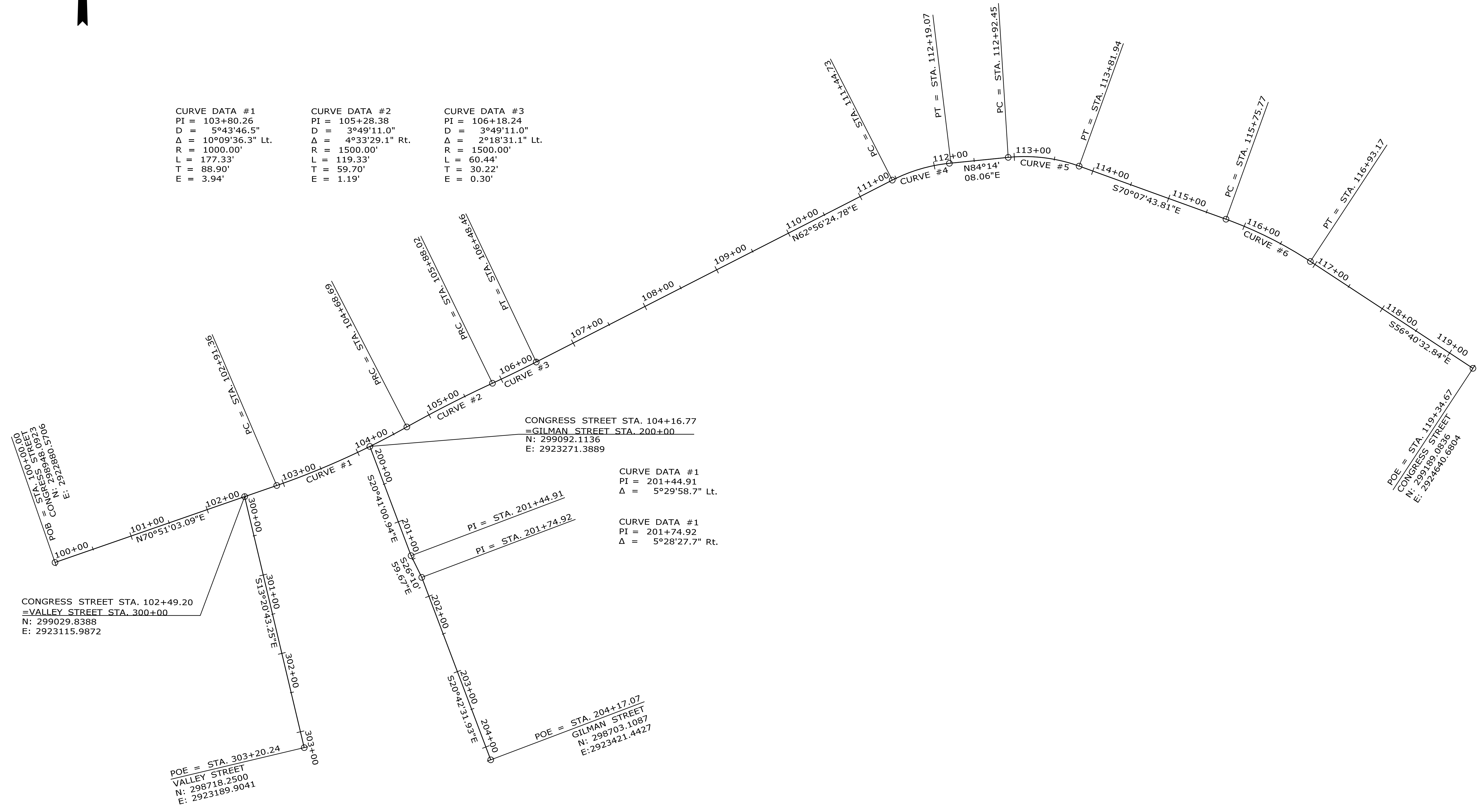

CONGRESS STREET STA. 102+49.20
 = VALLEY STREET STA. 300+00
 N: 299029.8388
 E: 2923115.9872

POE = STA. 303+20.24
 VALLEY STREET
 N: 298718.2500
 E: 2923189.9041

CONGRESS STREET STA. 104+16.77
 = GILMAN STREET STA. 200+00
 N: 299092.1136
 E: 2923271.3889

PI = STA. 201+44.91
 PI = STA. 201+74.92

POE = STA. 204+17.07
 GILMAN STREET
 N: 298703.1087
 E: 2923421.4427

CURVE DATA #1
 PI = 201+44.91
 Δ = 5°29'58.7" Lt.

CURVE DATA #1
 PI = 201+74.92
 Δ = 5°28'27.7" Rt.

PLS OR PE

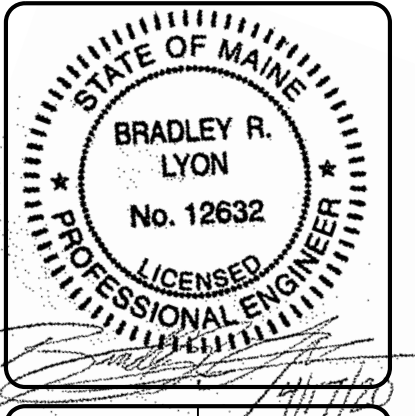



DESIGNED	CHECKED
NLS	BRL
1 NLS 04/17/20 100% FINAL CONTRACT PLANS	
REV/ BY:	DATE / STATUS:
THIS PLAN SHALL NOT BE MODIFIED WITHOUT WRITTEN PERMISSION FROM SEBAGO TECHNICS, INC. ANY ALTERATIONS AUTHORIZED OR OTHERWISE SHALL BE AT THE USER'S SOLE RISK AND WITHOUT LIABILITY TO SEBAGO TECHNICS, INC.	

SEBAGO
 TECHNICS
 WWW.SEBOGOTECHNICS.COM
 75 John Roberts Rd.
 Suite 4
 South Portland, ME 04106
 Tel: 207-200-2100

GEOMETRIC PLAN
 OF:
 MAINE MEDICAL CENTER
 OFF-SITE IMPROVEMENTS
 PORTLAND, MAINE
 FOR:
 MAINE MEDICAL CENTER
 22 BRANHALL STREET
 PORTLAND, ME 04102

PROJECT NO.	SCALE
15466	1" = 60'

CONSTRUCTION LEGEND

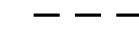
-  CONCRETE SIDEWALK
-  BRICK SIDEWALK
-  FULL DEPTH PAVEMENT REMOVAL
-  SAW CUT LINE

DETECTABLE WARNING FIELD

SIZE	DETECTABLE WARNING FIELD
2' X 6'	101+86 RT
2' X 6'	101+86 LT
2' X 6'	102+29 LT
2' X 6'	102+74 RT
2' X 6'	102+74 LT
2' X 6'	103+88 RT
2' X 6'	103+88 LT
2' X 6'	104+11 LT
2' X 8'	104+41 LT
2' X 6'	104+45 RT
2' X 6'	300+28 LT
2' X 6'	300+28 RT
2' X 6'	200+31 RT
2' X 6'	200+31 LT

- NOTES:**
- PROPOSED CONTOURS ARE SHOWN IN 0.5' INTERVALS AND ARE ONLY SHOWN WITHIN THE PROPOSED ROADWAY WHERE CONSTRUCTION OF FULL DEPTH PAVEMENT REPLACEMENT IS OCCURRING.
 - RIM ELEVATIONS, STATIONS, AND OFFSETS OF DRAINAGE STRUCTURES ARE TO THE CENTER OF THE STRUCTURE. RIM ELEVATIONS SHOWN ACCOUNT FOR DEPRESSION OF THE STRUCTURE AS NEEDED.

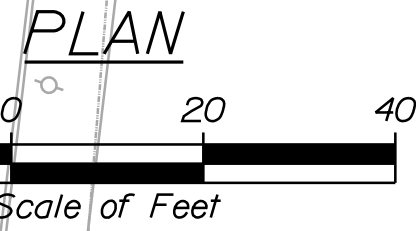
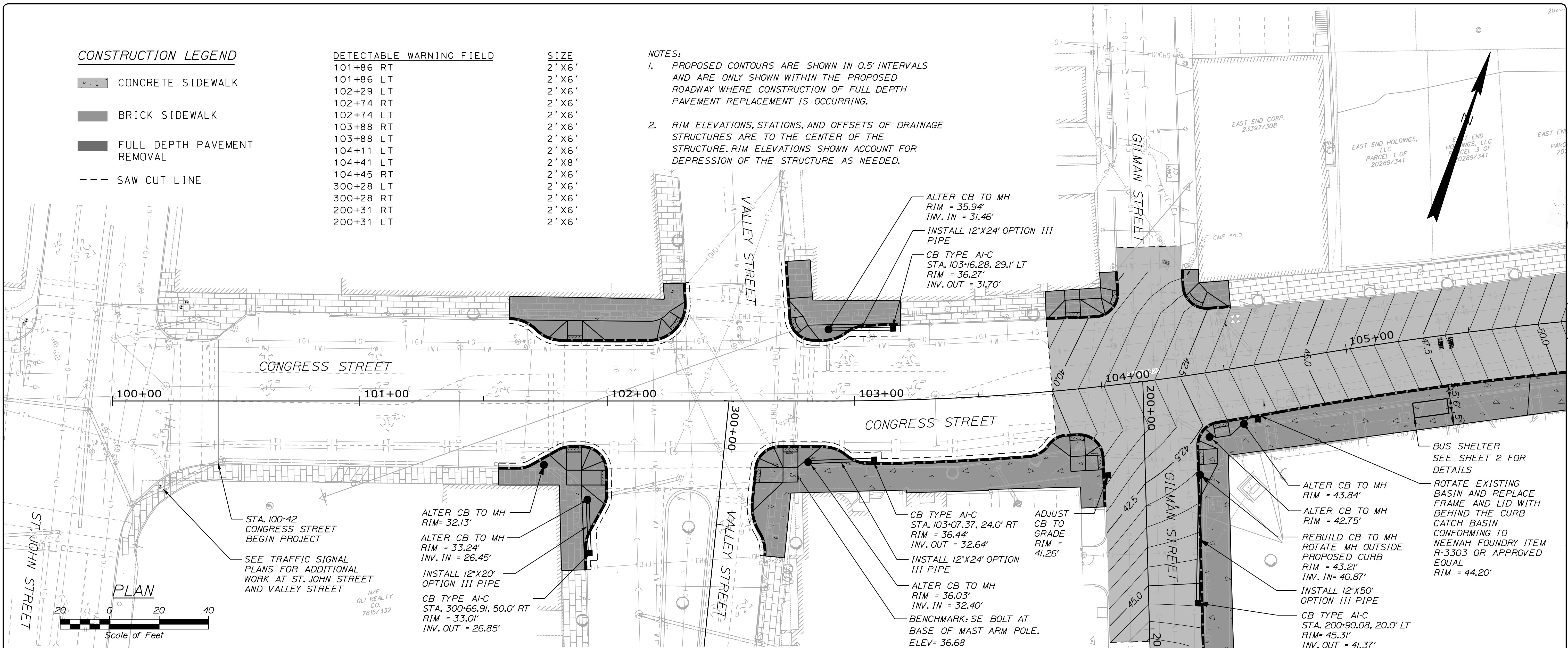

N/F
GLI REALTY
CO.
7815/332

ALTER CB TO MH
RIM = 32.13'
ALTER CB TO MH
RIM = 33.24'
INV. IN = 26.45'
INSTALL 12"X20"
OPTION III PIPE
CB TYPE A-C
STA. 300+66.91, 50.0' RT
RIM = 33.01'
INV. OUT = 26.85'

ALTER CB TO MH
RIM = 35.94'
INV. IN = 31.46'
INSTALL 12"X24' OPTION III
PIPE
CB TYPE A-C
STA. 103+16.28, 29.1' LT
RIM = 36.27'
INV. OUT = 31.70'

ALTER CB TO MH
RIM = 43.84'
ALTER CB TO MH
RIM = 42.75'
REBUILD CB TO MH
ROTATE MH OUTSIDE
PROPOSED CURB
RIM = 43.21'
INV. IN = 40.87'
INSTALL 12"X50'
OPTION III PIPE
CB TYPE A-C
STA. 200+90.08, 20.0' LT
RIM = 45.31'
INV. OUT = 41.37'

BUS SHELTER
SEE SHEET 2 FOR
DETAILS
ROTATE EXISTING
BASIN AND REPLACE
FRAME AND LID WITH
BEHIND THE CURB
CATCH BASIN
CONFORMING TO
NEENAH FOUNDRY ITEM
R-3303 OR APPROVED
EQUAL
RIM = 44.20'

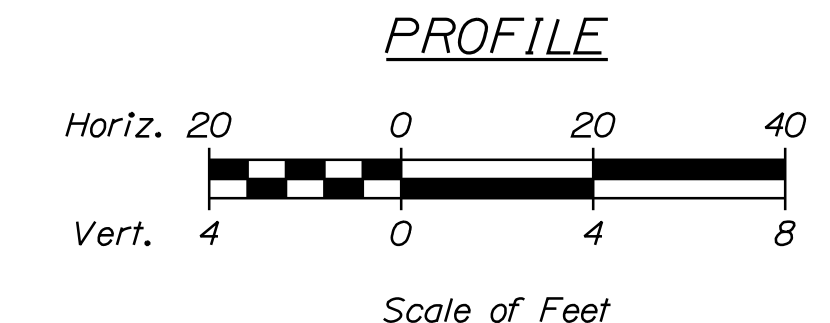
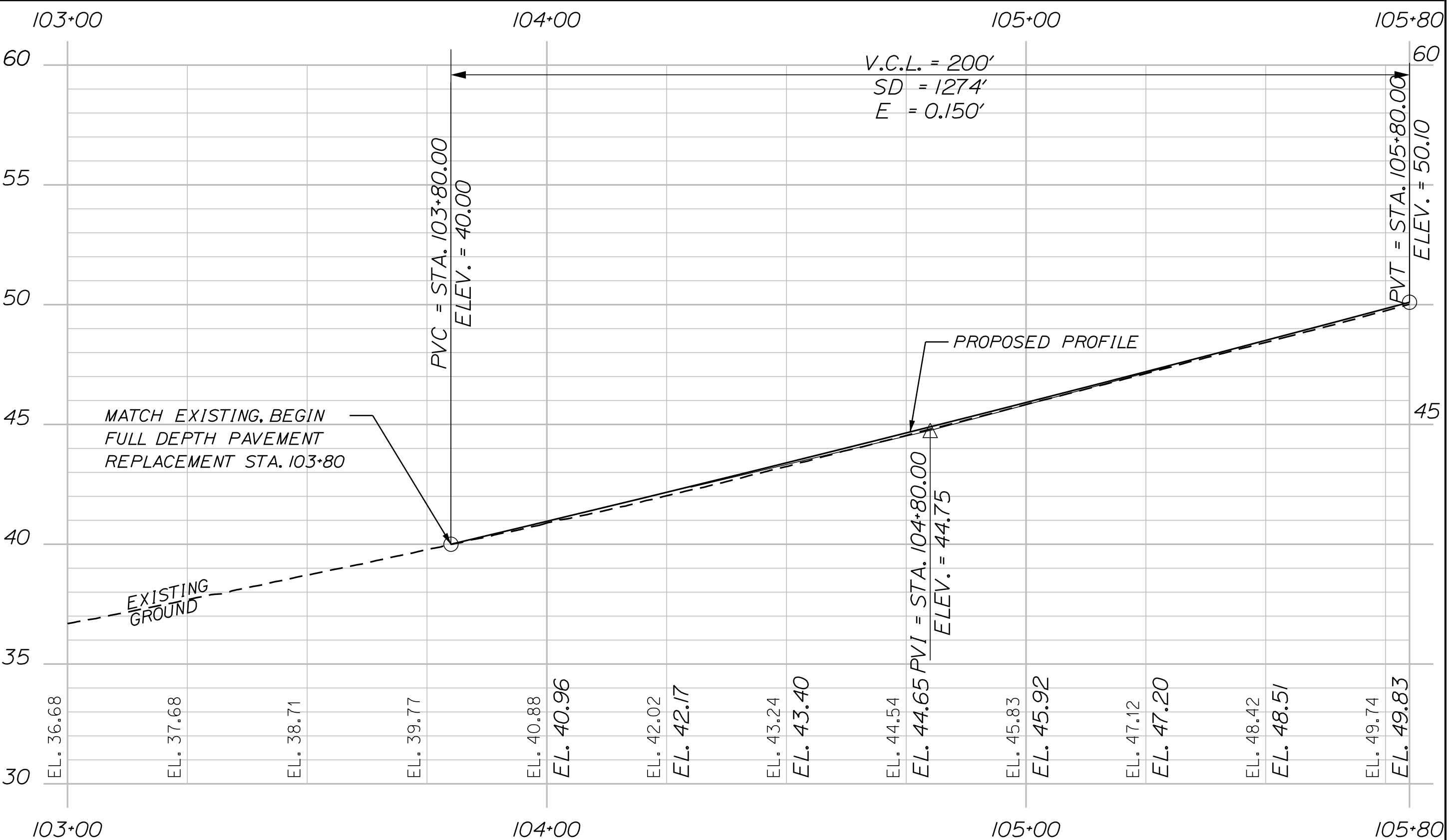

CONGRESS STREET PROFILE

PLS OR PE

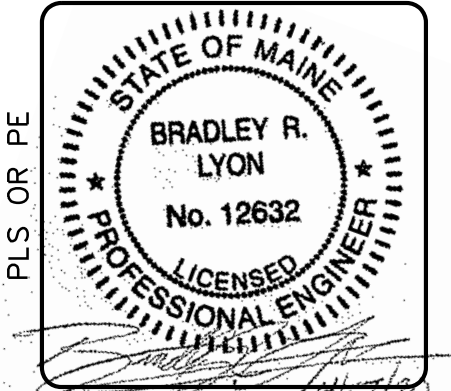

DESIGNED	CHECKED
SCK	BRL

1 SCK 04/17/20 100% FINAL CONTRACT PLANS
REV. BY: DATE: STATUS:
THIS PLAN SHALL NOT BE MODIFIED WITHOUT WRITTEN PERMISSION FROM SEBAGO TECHNICS, INC. ANY ALTERATIONS, AUTHORIZED OR OTHERWISE, SHALL BE AT THE USER'S SOLE RISK AND WITHOUT LIABILITY TO SEBAGO TECHNICS, INC.

SEBAGO
TECHNICS
WWW.SEBAGOTECHNICS.COM
75 John Roberts Rd.
Suite 4
South Portland, ME 04106
Tel. 207-209-2100

GENERAL PLAN AND PROFILE
OF
CONGRESS STREET
OFF-SITE IMPROVEMENTS
FOR
MAINE MEDICAL CENTER
22 BRANHALL STREET
PORTLAND, ME 04102

PROJECT NO.	SCALE
15466	1" = 20'

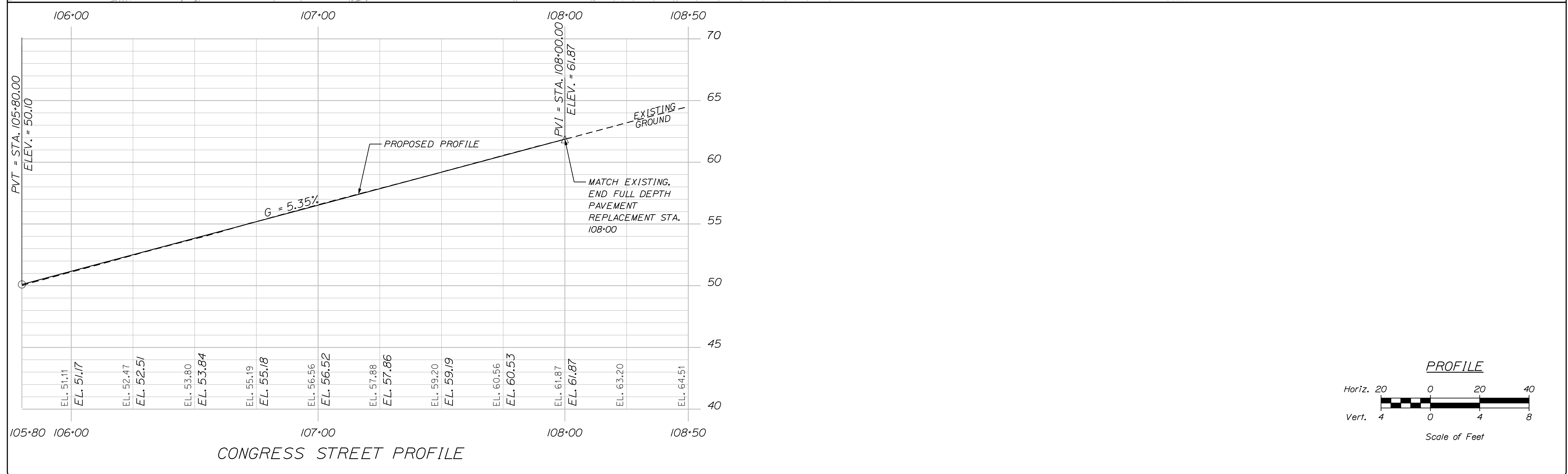
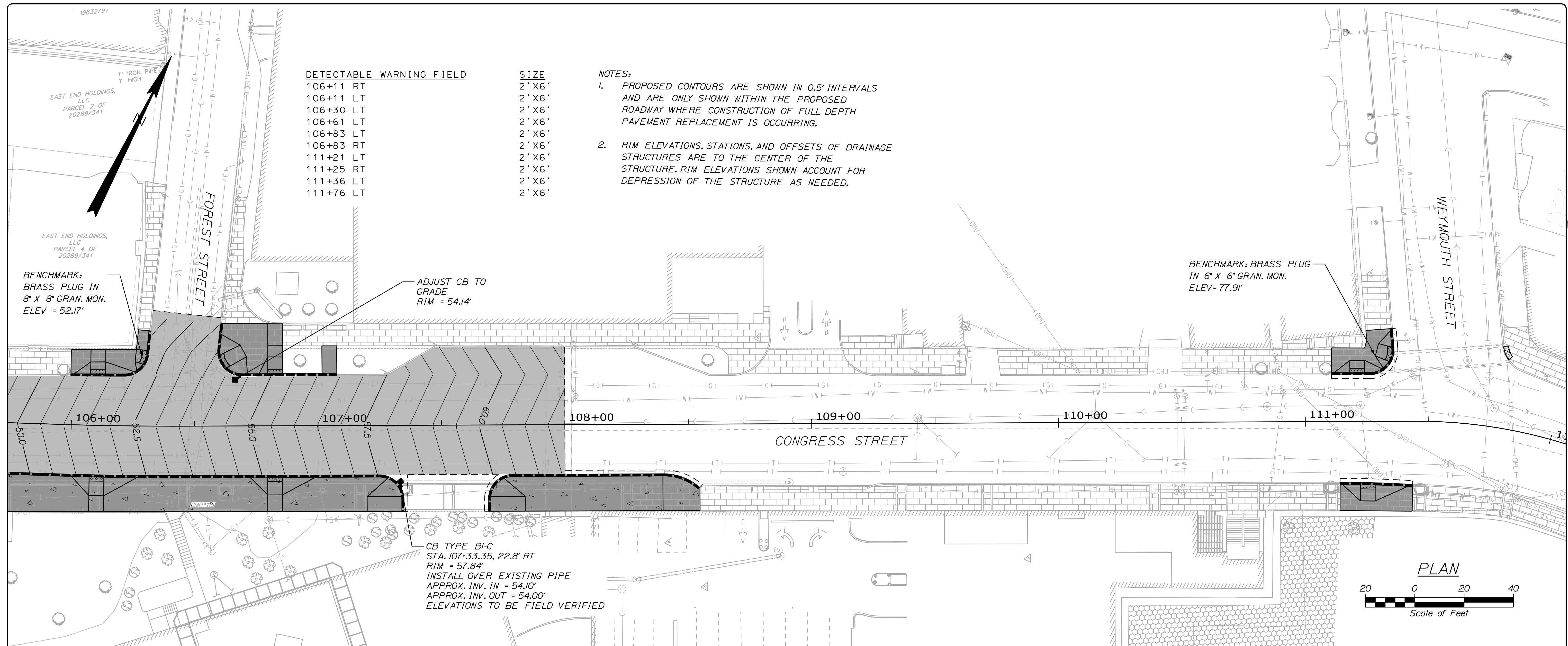

PLS OR PE

STATE OF MAINE
BRADLEY R. LYON
No. 12632
LICENSED PROFESSIONAL ENGINEER

DESIGNED	CHECKED
SCK	BRL

1 SCK 04/17/20 100% FINAL CONTRACT PLANS
REVIEW BY: DATE: STATUS:
THIS PLAN SHALL NOT BE MODIFIED WITHOUT WRITTEN PERMISSION FROM SEBAGO TECHNICS, INC. ANY ALTERATIONS, AUTHORIZED OR OTHERWISE, SHALL BE AT THE USER'S SOLE RISK AND WITHOUT LIABILITY TO SEBAGO TECHNICS, INC.

SEBAGO TECHNICS
WWW.SEBAGOTECHNICS.COM
75 John Roberts Rd.
Suite 4
South Portland, ME 04106
Tel. 207-209-2100

GENERAL PLAN AND PROFILE
OF
CONGRESS STREET
OFF-SITE IMPROVEMENTS
FOR:
MAINE MEDICAL CENTER
22 BRAMHALL STREET
PORTLAND, ME 04102

PROJECT NO. 15466 SCALE 1" = 20'

SHEET 5 OF 16

DETECTABLE WARNING FIELD	SIZE
203+18 LT	2' X 6'
203+18 RT	2' X 6'
203+33 RT	2' X 6'

- NOTES:
1. PROPOSED CONTOURS ARE SHOWN IN 0.5' INTERVALS AND ARE ONLY SHOWN WITHIN THE PROPOSED ROADWAY WHERE CONSTRUCTION OF FULL DEPTH PAVEMENT REPLACEMENT IS OCCURRING.
 2. RIM ELEVATIONS, STATIONS, AND OFFSETS OF DRAINAGE STRUCTURES ARE TO THE CENTER OF THE STRUCTURE. RIM ELEVATIONS SHOWN ACCOUNT FOR DEPRESSION OF THE STRUCTURE AS NEEDED.

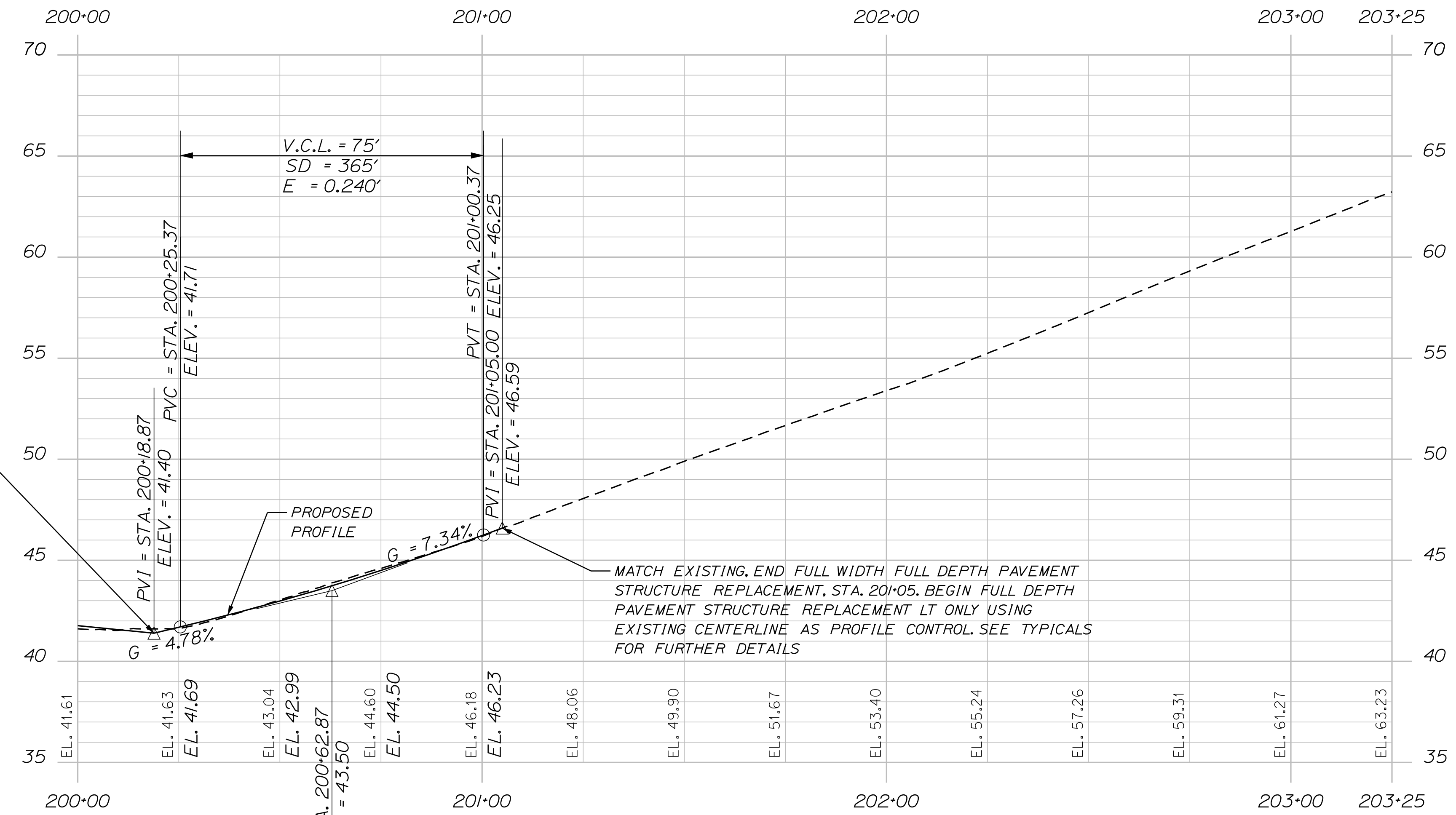
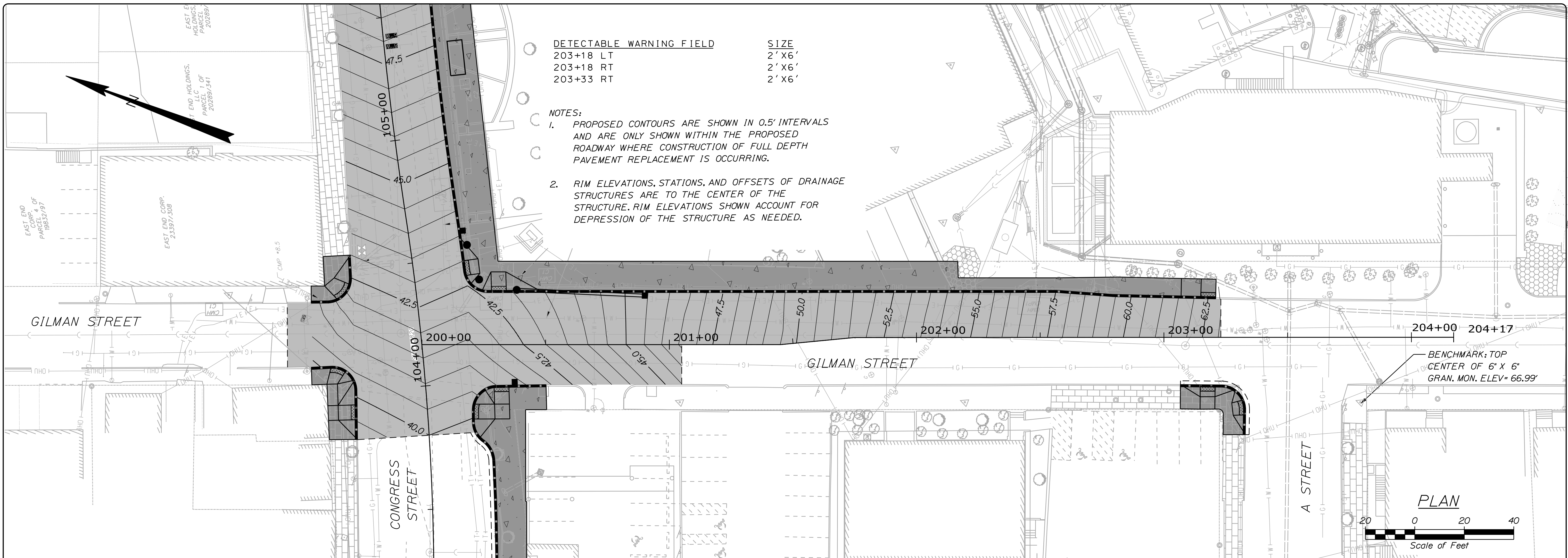

MATCH PROPOSED CONGRESS STREET CONSTRUCTION, BEGIN FULL DEPTH PAVEMENT STRUCTURE REPLACEMENT ALONG GILMAN STREET, STA. 200+18.87

MATCH EXISTING, END FULL WIDTH FULL DEPTH PAVEMENT STRUCTURE REPLACEMENT, STA. 201+05. BEGIN FULL DEPTH PAVEMENT STRUCTURE REPLACEMENT LT ONLY USING EXISTING CENTERLINE AS PROFILE CONTROL. SEE TYPICALS FOR FURTHER DETAILS

GILMAN STREET PROFILE

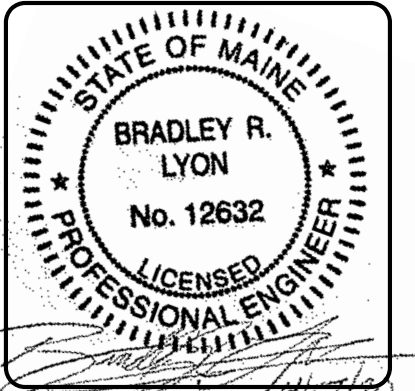
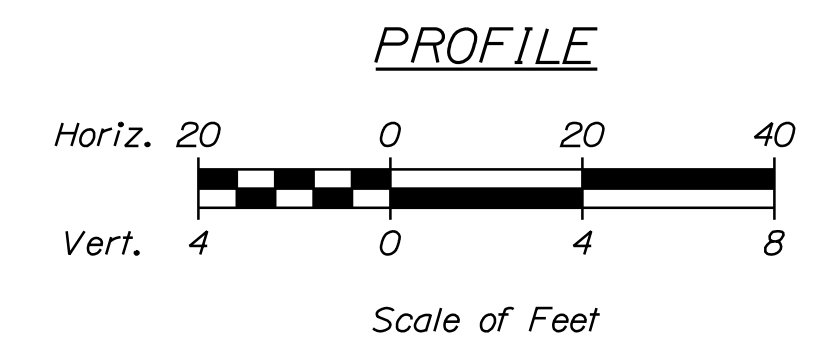

DESIGNED	CHECKED
SCK	BRL

1 SCK 04/17/20 100% FINAL CONTRACT PLANS
 REV. BY: DATE: STATUS:
 THE PLAN SHALL NOT BE MODIFIED WITHOUT WRITTEN PERMISSION FROM SEBAGO TECHNICS, INC. ANY ALTERATIONS, AUTHORIZED OR OTHERWISE, SHALL BE AT THE USER'S SOLE RISK AND WITHOUT LIABILITY TO SEBAGO TECHNICS, INC.

SEBAGO
 TECHNICS
 WWW.SEBAGOTECHNICS.COM
 75 John Roberts Rd.
 Suite 4
 South Portland, ME 04106
 Tel. 207-209-2100

GENERAL PLAN AND PROFILE
 OF
GILMAN STREET
 OFF-SITE IMPROVEMENTS
 FOR
MAINE MEDICAL CENTER
 22 BRANHALL STREET
 PORTLAND, ME 04102

PROJECT NO.	SCALE
15466	1" = 20'

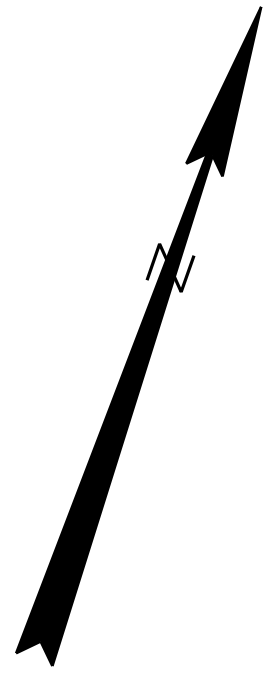

PAVEMENT MARKING LEGEND

SDYL	4" SOLID DOUBLE YELLOW LINE
SSWL	4" SOLID SINGLE WHITE LINE
6" SSWL	6" SOLID SINGLE WHITE LINE
SWSL	24" SOLID WHITE STOP LINE
SSYL	4" SOLID SINGLE YELLOW LINE
DOSWL	6" DOTTED SINGLE WHITE LINE
SSYCL	12" SOLID SINGLE YELLOW CHEVRON LINE

PAVEMENT MARKING NOTES:

1. ALL PAVEMENT MARKINGS SHALL BE IN CONFORMANCE WITH THE MANUAL ON UNIFORM TRAFFIC CONTROL DEVICES FOR STREETS AND HIGHWAYS, U.S. DOT, FHWA, 2009 EDITION.
2. ALL PAVEMENT MARKINGS SHALL BE PAINT AND SHALL BE FURNISHED AND INSTALLED IN ACCORDANCE WITH MAINEDOT STANDARD SPECIFICATION 627.
3. REMOVAL OF PAVEMENT MARKINGS AS NECESSARY TO PROVIDE THE FINAL STRIPING LAYOUT OUTLINED IN THESE PLANS SHALL BE COMPLETED PER MAINEDOT STANDARD SPECIFICATION 627.08.

SIGNAGE LEGEND

NEW	FURNISH AND INSTALL NEW
R&R	REMOVE AND RESET
R&S	REMOVE AND SALVAGE

SIGN DETAILS
NOT TO SCALE

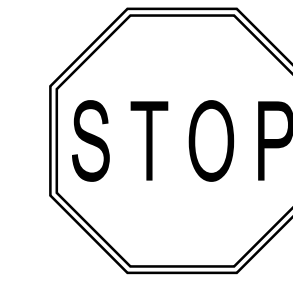

RI-1
30"X30"



W11-2
30"X30"

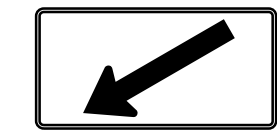

W16-7PL
24"X12"

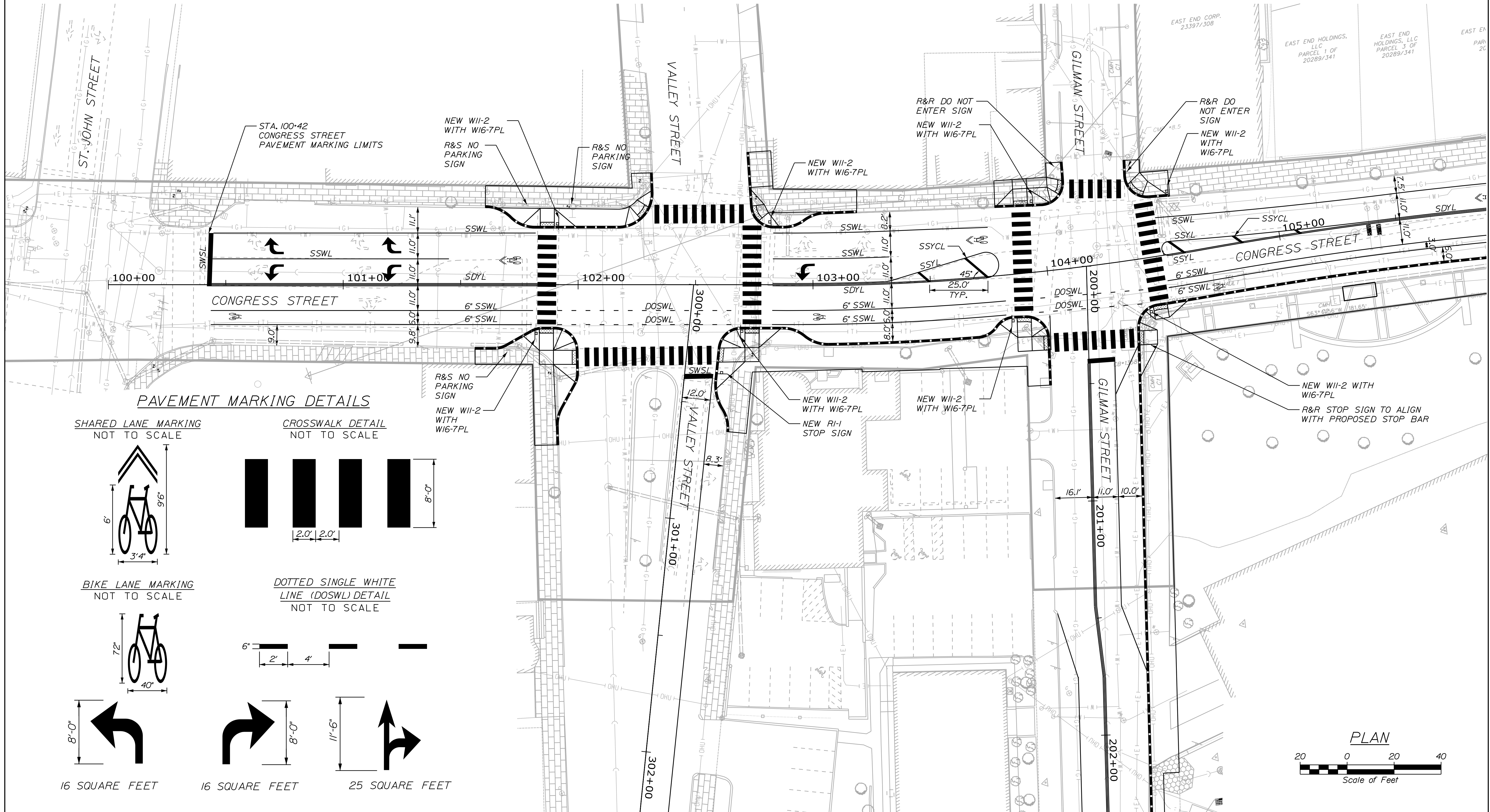

PAVEMENT MARKING DETAILS

SHARED LANE MARKING
NOT TO SCALE

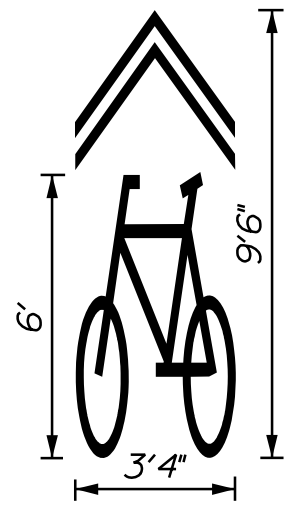

BIKE LANE MARKING
NOT TO SCALE

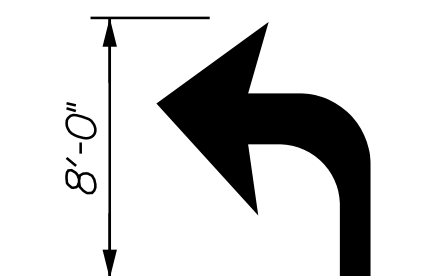
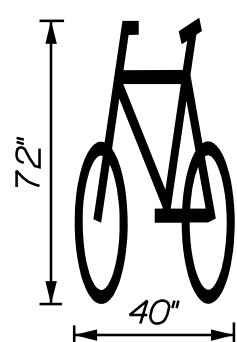

16 SQUARE FEET

CROSSWALK DETAIL
NOT TO SCALE

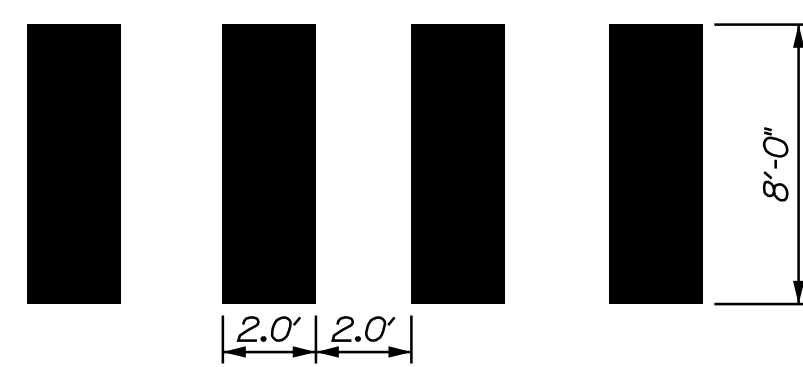

DOTTED SINGLE WHITE
LINE (DOSWL) DETAIL
NOT TO SCALE

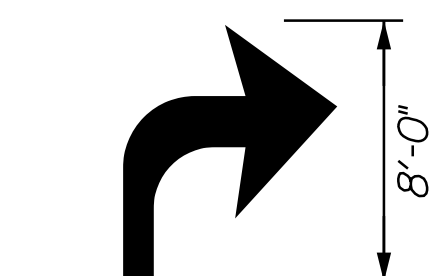
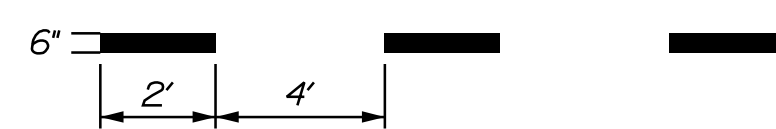

16 SQUARE FEET

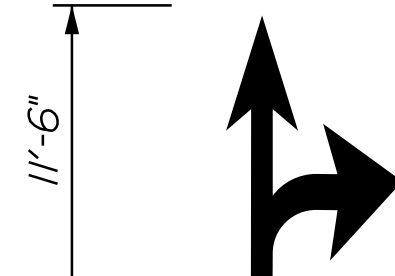

25 SQUARE FEET

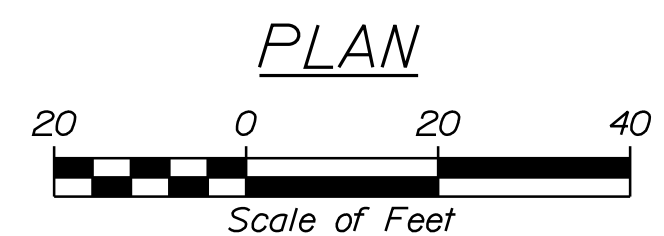

PLS OR PE

STATE OF MAINE
BRADLEY R. LYON
No. 12632
LICENSED PROFESSIONAL ENGINEER

DESIGNED NLS	CHECKED BRL
1 NLS 04/17/20 100% FINAL CONTRACT PLANS	
REV. BY: DATE: STATUS:	
THIS PLAN SHALL NOT BE MODIFIED WITHOUT WRITTEN PERMISSION FROM SEBAGO TECHNICS, INC. ANY ALTERATIONS, AUTHORIZED OR OTHERWISE, SHALL BE AT THE USER'S SOLE RISK AND WITHOUT LIABILITY TO SEBAGO TECHNICS, INC.	

SEBAGO

TECHNICS
WWW.SEBOGOTECHNICS.COM
75 John Roberts Rd.
South Portland, ME 04106
Tel: 207-209-2100

PAVEMENT MARKING & SIGNING PLAN
OF
**CONGRESS STREET
OFF-SITE IMPROVEMENTS**
FOR:
MAINE MEDICAL CENTER
22 BRANHALL STREET
PORTLAND, ME 04102

PROJECT NO. 15466	SCALE 1" = 20'
----------------------	-------------------

SHEET 7 OF 16

PLS OR PE

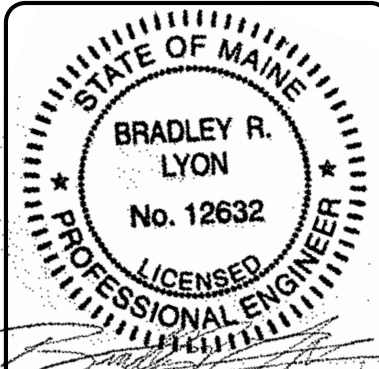

DESIGNED	CHECKED
NLS	BRL
1 NLS 04/17/20 100% FINAL CONTRACT PLANS	
REV. BY:	DATE:
STATUS:	
THE PLAN SHALL NOT BE MODIFIED WITHOUT WRITTEN PERMISSION FROM SEBAGO TECHNICS, INC. ANY ALTERATIONS, AUTHORIZED OR OTHERWISE, SHALL BE AT THE USER'S SOLE RISK AND WITHOUT LIABILITY TO SEBAGO TECHNICS, INC.	

SEBAGO
TECHNICS

WWW.SEAGOTECHNICS.COM
75 John Roberts Rd.
South Portland, ME 04106
Tel. 207-209-2100

PAVEMENT MARKING & SIGNING PLAN
OF
CONGRESS STREET
OFF-SITE IMPROVEMENTS
PORTLAND, MAINE
FOR:
MAINE MEDICAL CENTER
22 BRANHALL STREET
PORTLAND, ME 04102

PROJECT NO.	SCALE
15466	1" = 20'

SHEET 8 OF 16

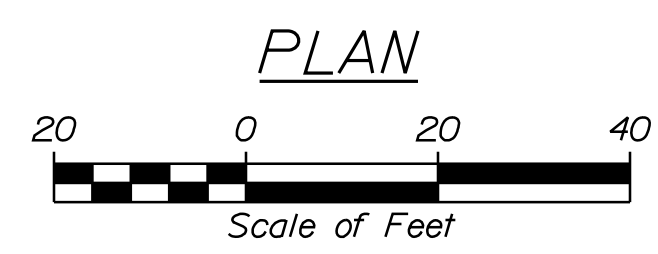
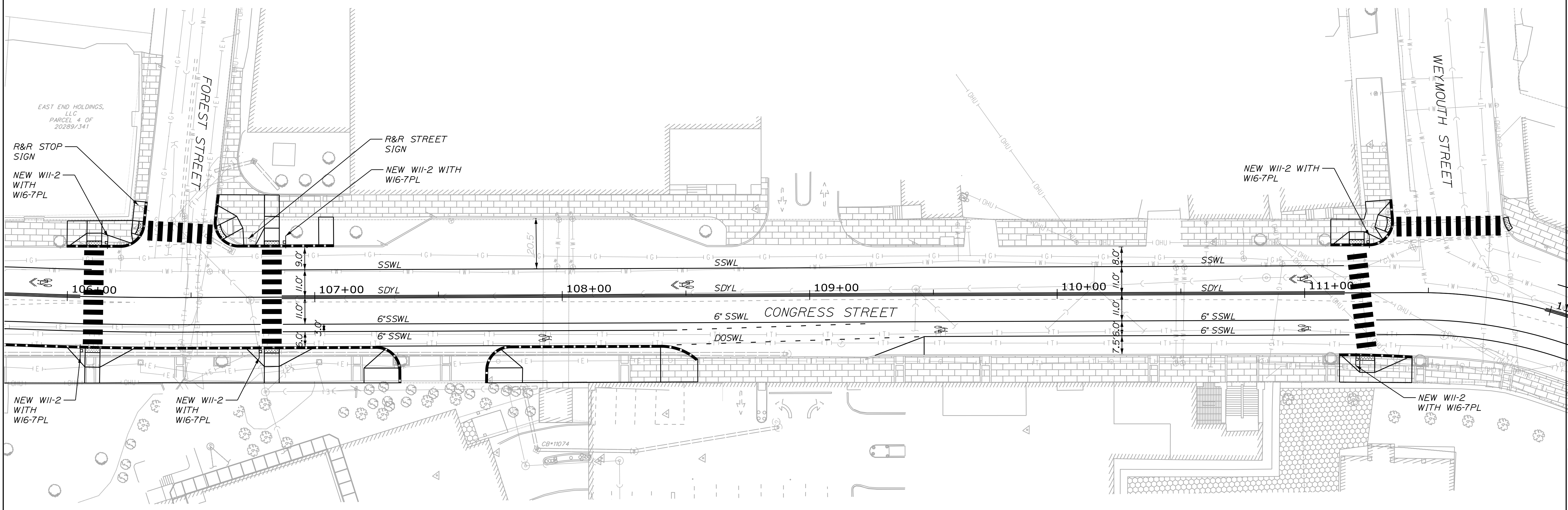
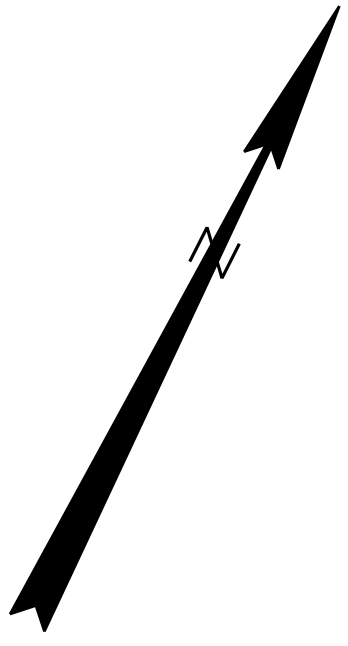

PLS OR PE

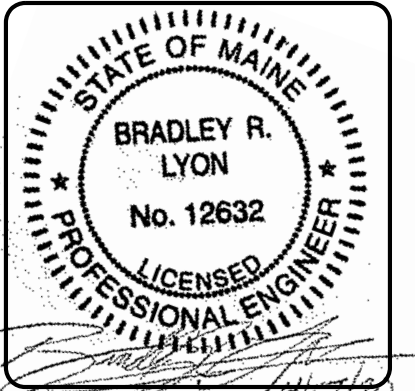

DESIGNED	CHECKED
NLS	BRL
1 NLS 04/17/20 100% FINAL CONTRACT PLANS	
REV. BY: DATE: STATUS:	
THE PLAN SHALL NOT BE MODIFIED WITHOUT WRITTEN PERMISSION FROM SEBAGO TECHNICS, INC. ANY ALTERATIONS AUTHORIZED OR OTHERWISE, SHALL BE AT THE USER'S SOLE RISK AND WITHOUT LIABILITY TO SEBAGO TECHNICS, INC.	

SEBAGO
TECHNICS
WWW.SEBAGOTECHNICS.COM
75 John Roberts Rd.
Suite 4
South Portland, ME 04106
Tel. 207-209-2100

PAVEMENT MARKING & SIGNING PLAN
OF
CONGRESS STREET
OFF-SITE IMPROVEMENTS
FOR
MAINE MEDICAL CENTER
22 BRANHALL STREET
PORTLAND, ME 04102

PROJECT NO.	SCALE
15466	1" = 20'

SHEET 9 OF 16

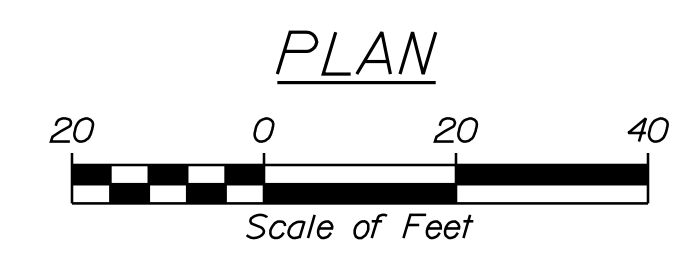
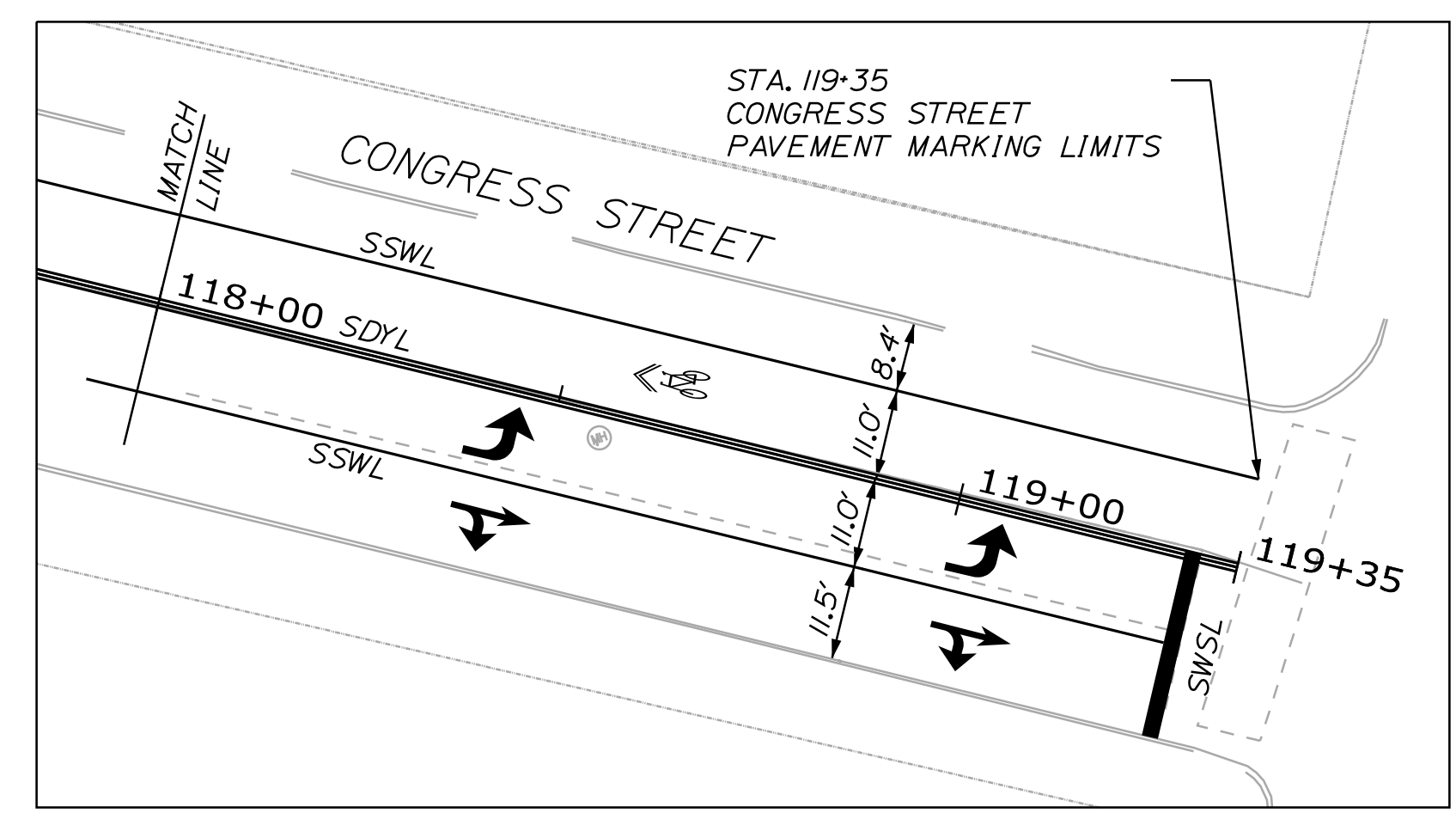
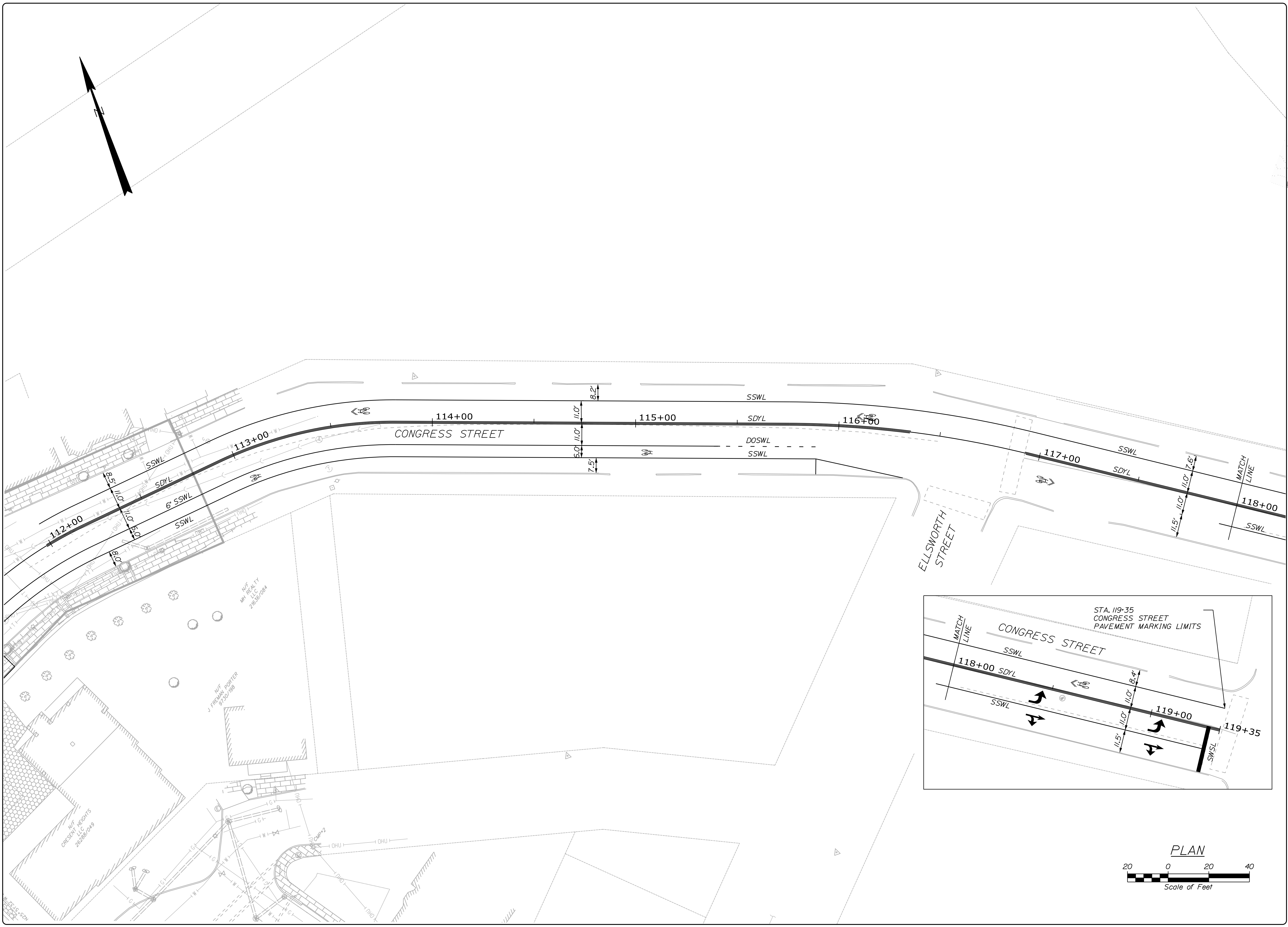

PLAN

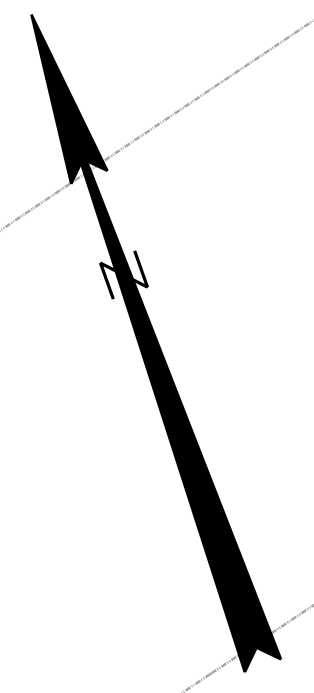

ME-615-S2N

NF
CRESENT HEIGHTS
L.L.C.
28288/049

NF
J. FROMM PORTER
9/20/08

NF
M4 NGLEY
L.L.C.
2/6/08/084

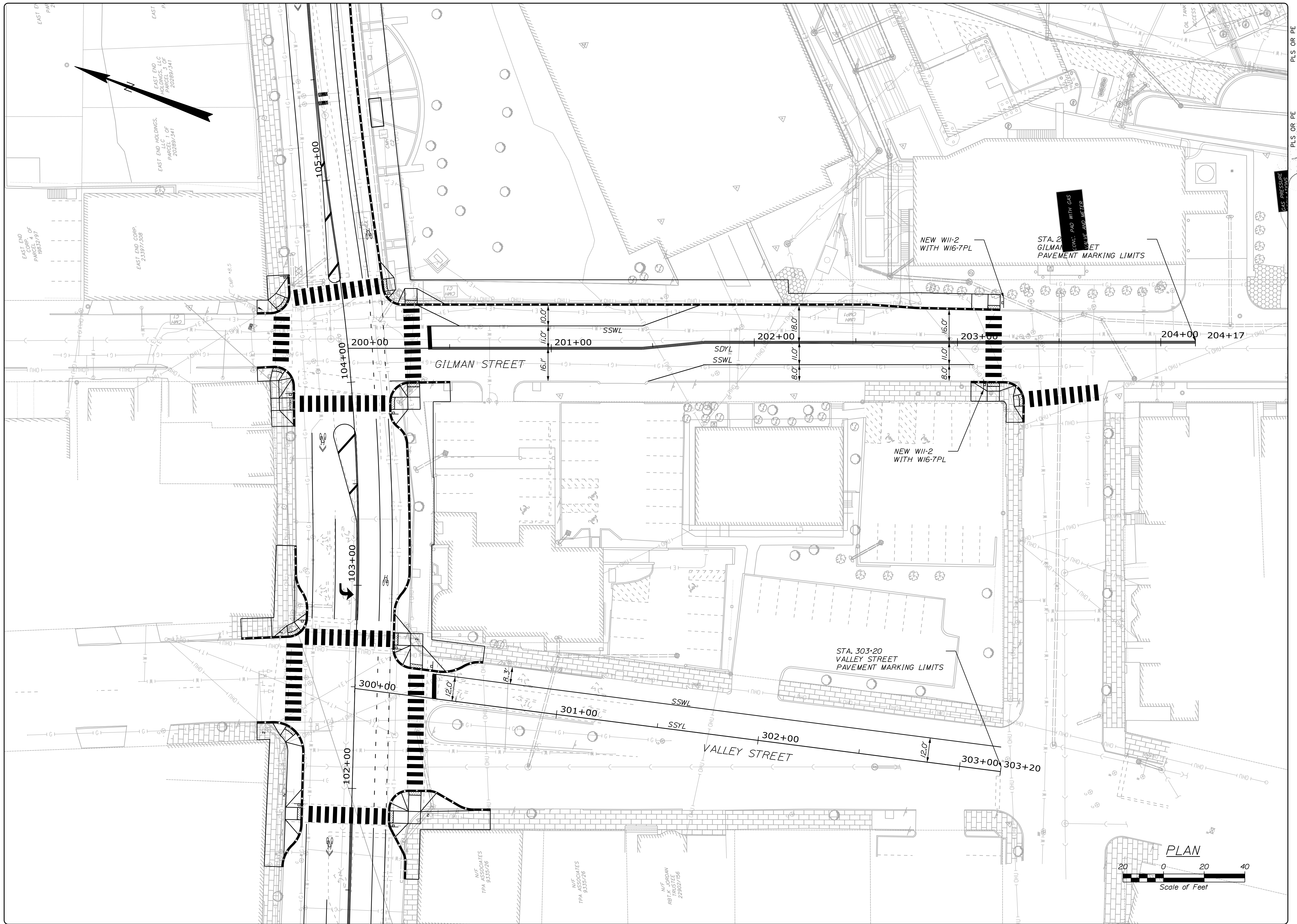

PLS. OR PE

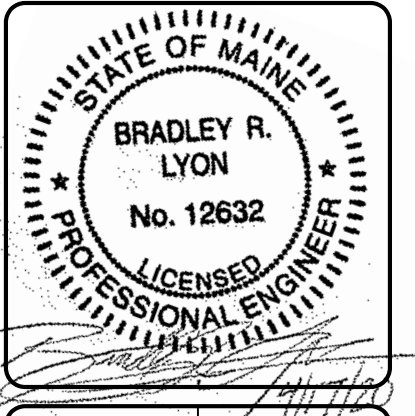

DESIGNED	CHECKED
NLS	BRL
1 NLS 04/17/20 100% FINAL CONTRACT PLANS REV. BY: DATE: STATUS: THIS PLAN SHALL NOT BE MODIFIED WITHOUT WRITTEN PERMISSION FROM SEBAGO TECHNICS, INC. ANY ALTERATIONS, AUTHORIZED OR OTHERWISE, SHALL BE AT THE USER'S SOLE RISK AND WITHOUT LIABILITY TO SEBAGO TECHNICS, INC.	

SEBAGO
TECHNICS
WWW.SEBAGOTECHNICS.COM
75 John Roberts Rd.
Suite 4
South Portland, ME 04106
Tel. 207-209-2100

PAVEMENT MARKING & SIGNING PLAN
OF
VALLEY STREET AND GILMAN STREET
OFF-SITE IMPROVEMENTS
FOR:
MAINE MEDICAL CENTER
22 BRAMHALL STREET
PORTLAND, ME 04102

PROJECT NO.	SCALE
15466	1" = 20'

NEW VERTICAL CURB TYPE 1		
POINT TO POINT	RADIUS (FT)	LENGTH (LF)
13 TO 14 (FLUSH)	-	6
15 TO 16	-	17.1
20 TO 21	-	7.2
22 TO 23	-	15
28 TO 29	-	13.6
31 TO 32	-	6
41 TO 42	-	8
43 TO 44	-	8.1
45 TO 46 (FLUSH)	-	6
49 TO 50	-	6
51 TO 52	-	12.2
53 TO 54	-	8
57 TO 58	-	12
58 TO 59 (FLUSH)	-	6
62 TO 63 (FLUSH)	-	6
66 TO 67	1025	63.8
70 TO 71 (FLUSH)	-	6
73 TO 74 (FLUSH)	-	6
78 TO 79 (FLUSH)	-	6
82 TO 83 (FLUSH)	1020	6
84 TO 85	1020	10.9
SHEET SUBTOTAL (LF)		236

NEW TERMINAL CURB TYPE 1 - CIRCULAR		
POINT TO POINT	RADIUS (FT)	LENGTH (LF)
12 TO 13	15	8
17 TO 18	15	8
19 TO 20	15	8
15 TO 16	10	12
33 TO 34	10	4
44 TO 45	10	8
46 TO 47	10	4
48 TO 49	10	4
50 TO 51	10	8
59 TO 60	10	4
69 TO 70	10	8
71 TO 72	10	8
72 TO 73	10	4
79 TO 80	10	4
81 TO 82	10	4
SHEET SUBTOTAL (LF)		96

CONTROL POINTS FOR CONGRESS STREET		
POINT	STATION	OFFSET
10	101+60.52	32.8' LT
11	101+70.94	28.5' LT
12	101+75.84	25.2' LT
13	101+83.84	24.0' LT
14	101+89.84	24.0' LT
15	101+99.84	24.0' LT
16	102+16.98	24.0' LT
17	102+19.84	24.3' LT
18	102+26.86	27.8' LT
19	102+30.57	32.7' LT
20	102+31.93	40.5' LT
21	102+31.62	47.7' LT
22	102+71.77	56.4' LT
23	102+72.75	41.4' LT
24	102+73.28	33.4' LT
25	102+94.79	24.4' LT

CONTROL POINTS FOR CONGRESS STREET		
POINT	STATION	OFFSET
26	102+86.17	24.0' LT
27	102+96.77	27.1' LT
28	103+05.40	30.0' LT
29	103+19.43	30.2' LT
30	103+80.09	29.0' LT
31	103+88.31	28.6' LT
32	103+94.48	28.2' LT
33	104+04.79	28.4' LT
34	104+09.19	31.4' LT
35	104+11.55	37.3' LT
36	104+11.91	45.3' LT
37	104+38.73	42.6' LT
38	104+38.56	31.6' LT
39	104+44.39	25.8' LT
40	104+56.61	24.4' LT
41	101+56.17	26.6' RT

NEW TERMINAL CURB TYPE 1		
POINT TO POINT	RADIUS (FT)	LENGTH (LF)
14 TO 15	-	10
23 TO 24	-	8
30 TO 31	-	8
32 TO 33	-	10
35 TO 36	-	8
37 TO 38	-	11
39 TO 40	-	12
61 TO 62	-	4
63 TO 64	-	10
74 TO 75	-	15
77 TO 78	-	15
83 TO 84	1020	10
SHEET SUBTOTAL (LF)		121

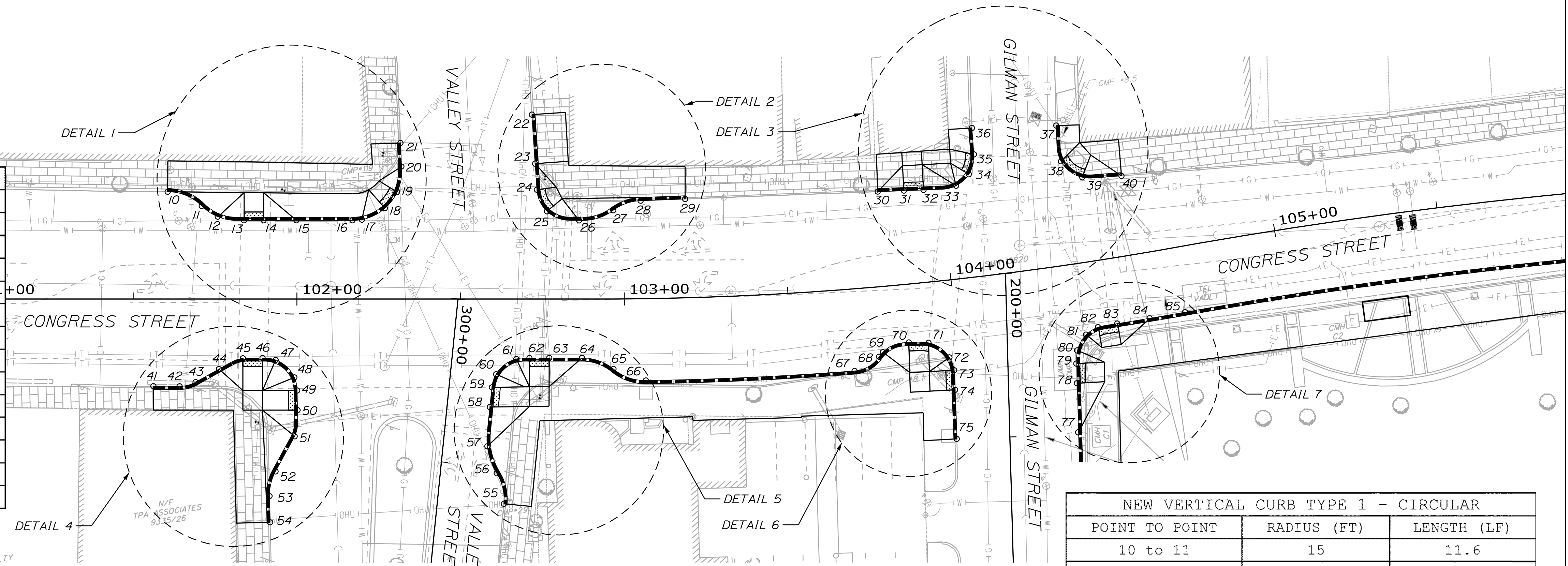

NEW VERTICAL CURB TYPE 1 - CIRCULAR		
POINT TO POINT	RADIUS (FT)	LENGTH (LF)
10 TO 11	15	11.6
11 TO 12	15	5.9
16 TO 17	15	2.8
18 TO 19 (FLUSH)	15	6
24 TO 25 (FLUSH)	10	6
26 TO 27	15	11.2
27 TO 28	15	9.1
34 TO 35 (FLUSH)	10	6
38 TO 39 (FLUSH)	10	8
42 TO 43	10	5.1
47 TO 48	10	9.8
52 TO 53	15	7.8
55 TO 56	15	9.8
56 TO 57	20	8.7
60 TO 61	10	8
64 TO 65	15	10.5
65 TO 66	15	10.5
67 TO 68	10	8.9
68 TO 69	10	2
80 TO 81	10	5.6
SHEET SUBTOTAL (LF)		154

CONTROL POINTS FOR CONGRESS STREET		
POINT	STATION	OFFSET
42	101+64.17	26.7' RT
43	101+69.05	25.4' RT
44	101+76.19	21.4' RT
45	101+83.50	18.0' RT
46	101+89.50	18.0' RT
47	101+93.50	18.6' RT
48	101+99.24	24.0' RT
49	102+00.00	27.9' RT
50	102+00.00	33.9' RT
51	300+46.78	45.4' RT
52	300+58.03	50.1' RT
53	300+65.72	51.2' RT
54	300+73.66	50.2' RT
55	300+80.82	20.3' RT
56	300+51.76	17.0' RT

CONTROL POINTS FOR CONGRESS STREET		
POINT	STATION	OFFSET
57	300+43.87	13.5' RT
58	102+58.92	33.0' RT
59	102+59.53	27.0' RT
60	102+60.84	23.0' RT
61	102+67.03	18.3' RT
62	102+71.03	18.0' RT
63	102+77.07	18.0' RT
64	102+87.07	18.0' RT
65	102+96.58	21.4' RT
66	103+06.20	25.0' RT
67	103+68.49	25.0' RT
68	103+76.12	21.3' RT
69	103+77.38	20.0' RT
70	103+85.37	17.8' RT
71	103+91.24	18.4' RT

CONTROL POINTS FOR CONGRESS STREET		
POINT	STATION	OFFSET
72	103+97.01	23.5' RT
73	103+98.01	27.6' RT
74	200+35.15	16.3' RT
75	200+50.15	16.3' RT
77	200+49.15	20.9' LT
78	200+34.14	20.9' LT
79	104+34.25	30.2' RT
80	104+35.02	26.3' RT
81	104+38.32	21.9' RT
82	104+42.21	20.2' RT
83	104+48.09	20.0' RT
84	104+57.89	20.0' RT
85	104+68.66	20.0' RT

- NOTES:**
- CURB RAMPS HAVE BEEN DESIGNED TO COMPLY TO THE MAXIMUM EXTENT FEASIBLE TO THE MOST RECENT MAINEDOT STANDARD DETAIL 80(KII).
 - ELEVATION 1 IS PROVIDED FOR ROADWAY ELEVATIONS AND ELEVATION 2 IS FOR SIDEWALK ELEVATIONS.

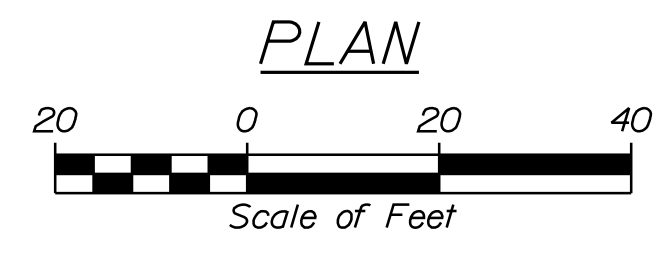

PLS OR PE

DESIGNED	CHECKED
NLS	BRL

1 NLS 04/17/20 100% FINAL CONTRACT PLANS
 REV. BY: DATE: STATUS:
 THIS PLAN SHALL NOT BE MODIFIED WITHOUT WRITTEN PERMISSION FROM SEBAGO TECHNICS, INC. ANY ALTERATIONS AUTHORIZED OR OTHERWISE, SHALL BE AT THE USER'S SOLE RISK AND WITHOUT LIABILITY TO SEBAGO TECHNICS, INC.

WWW.SEBAGOTECHNICS.COM
 75 John Roberts Rd.
 Suite 4
 South Portland, ME 04106
 Tel. 207-209-2100

CURB PLAN
 OF
 CONGRESS STREET
 OFF-SITE IMPROVEMENTS
 FOR:
 MAINE MEDICAL CENTER
 22 BRANHALL STREET
 PORTLAND, ME 04102

PROJECT NO.	SCALE
15466	1" = 20'

SHEET 11 OF 16

DETAIL 1

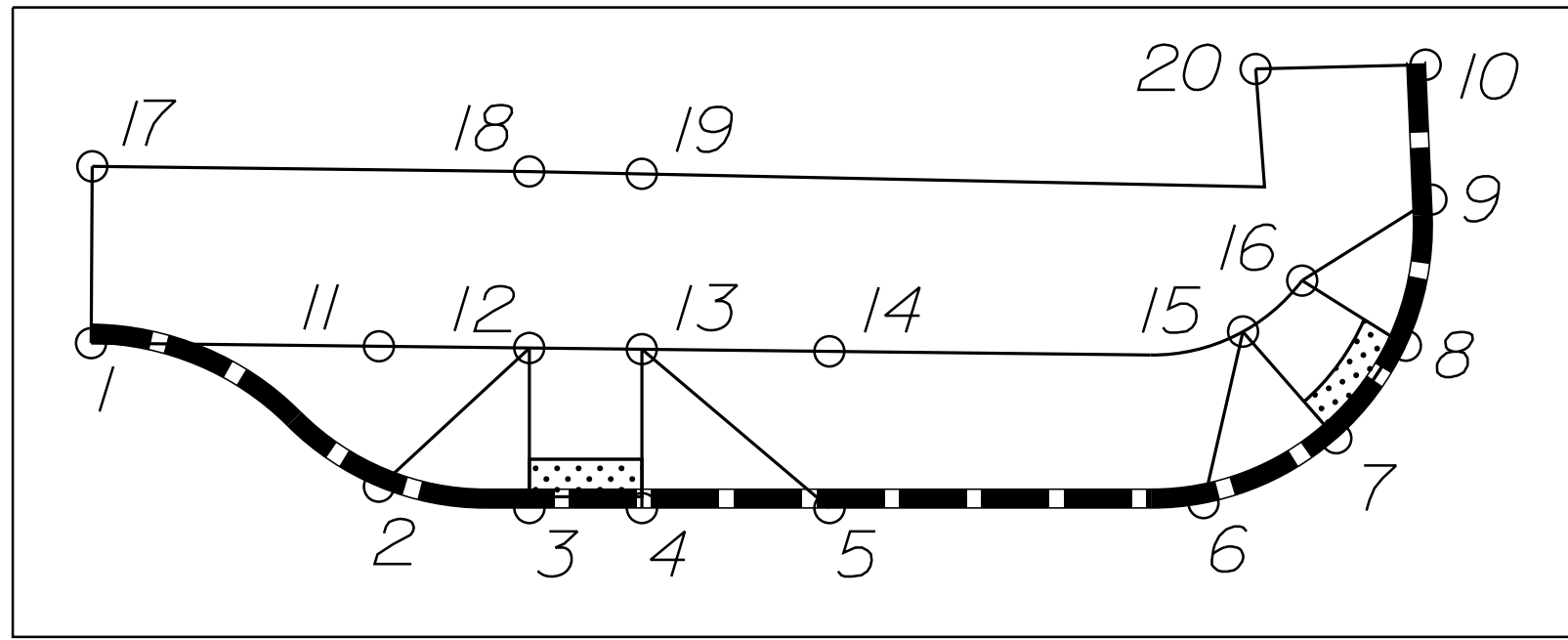

DETAIL 2

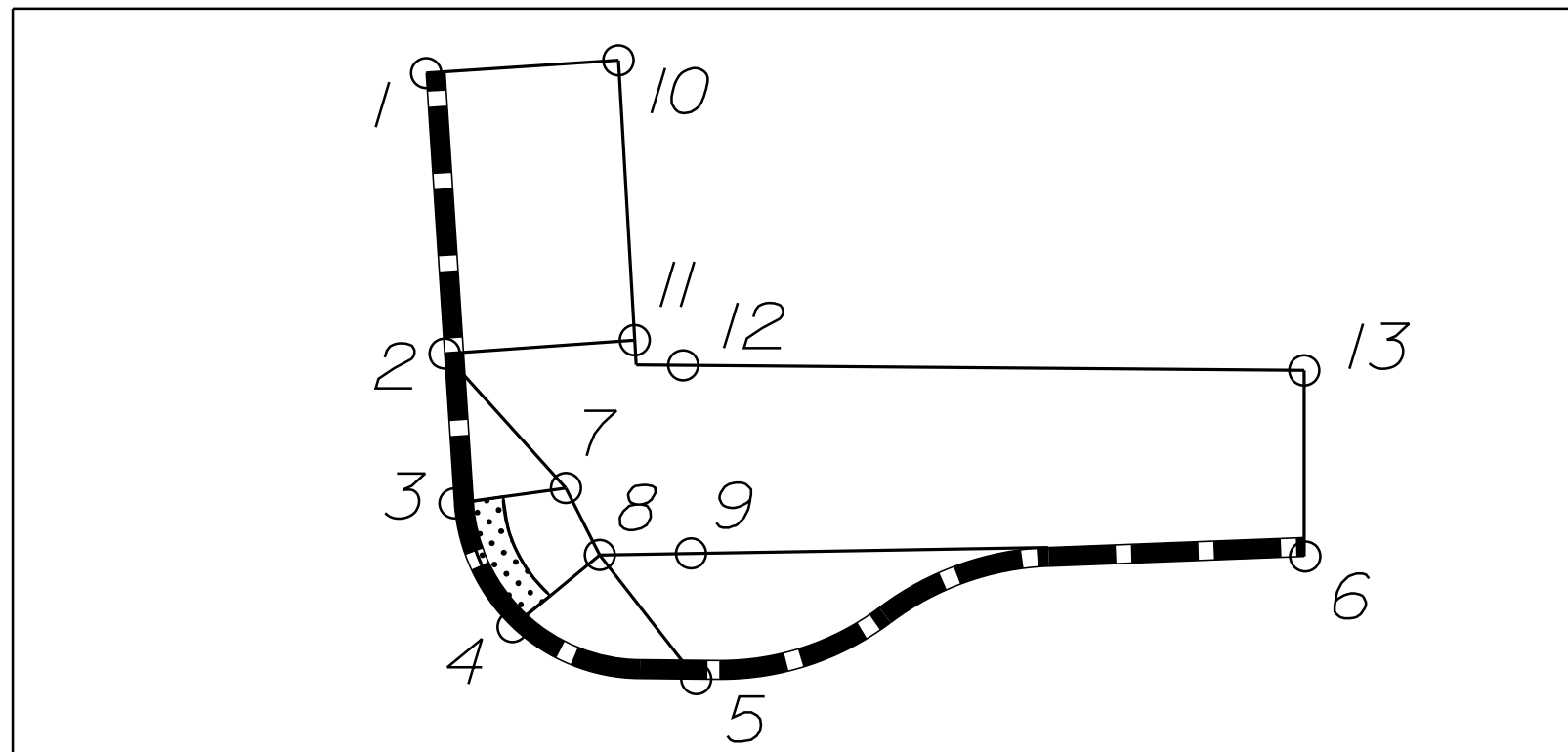

DETAIL 3

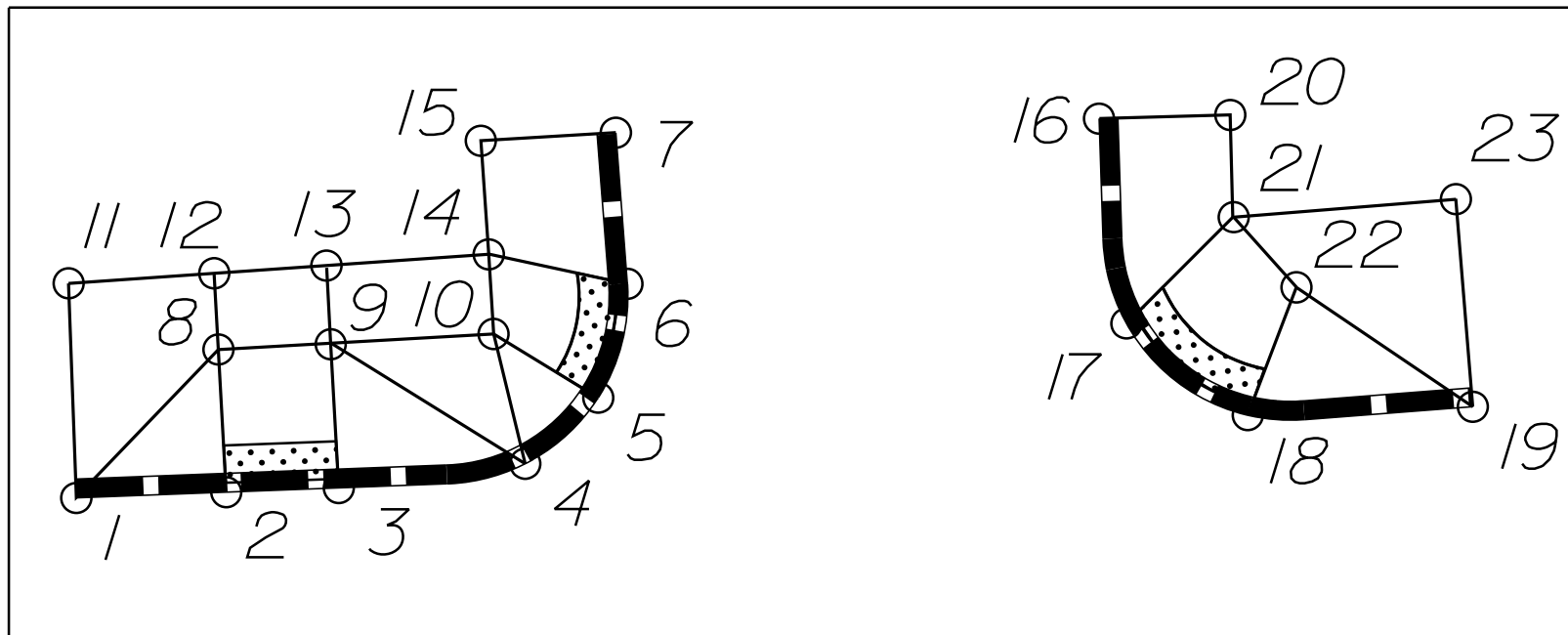

DETAIL 1 SPOT GRADES				
POINT	STATION	OFFSET	ELEV. 1	ELEV. 2
1	101+60.52	32.8' LT	30.15'	30.54'
2	101+75.84	25.2' LT	31.08'	31.50'
3	101+83.84	24.0' LT	31.42'	-
4	101+89.84	24.0' LT	31.65'	-
5	101+99.84	24.0' LT	32.01'	32.42'
6	102+19.84	32.7' LT	32.76'	33.17'
7	102+26.86	27.8' LT	32.91'	-
8	102+30.57	32.7' LT	32.85'	-
9	102+31.93	40.5' LT	32.53'	32.86'
10	102+31.62	47.7' LT	31.87'	32.18'
11	101+75.89	32.6' LT	-	31.22'
12	101+83.89	32.5' LT	-	31.57'
13	101+89.88	32.5' LT	-	31.69'
14	101+99.89	32.4' LT	-	32.04'
15	102+21.94	33.4' LT	-	32.94'
16	102+25.09	36.1' LT	-	32.88'
17	101+60.58	42.2' LT	-	30.62'
18	101+83.88	41.9' LT	-	31.62'
19	101+89.86	41.8' LT	-	31.81'
20	102+22.61	47.4' LT	-	31.69'

DETAIL 2 SPOT GRADES				
POINT	STATION	OFFSET	ELEV. 1	ELEV. 2
1	102+71.77	56.4' LT	32.16'	32.78'
2	102+72.75	41.4' LT	33.81'	34.39'
3	102+73.28	33.4' LT	34.77'	-
4	102+94.79	24.4' LT	34.87'	-
5	102+86.17	24.0' LT	35.36'	35.78'
6	103+19.43	30.2' LT	36.48'	36.91'
7	102+79.22	34.2' LT	-	34.71'
8	102+81.02	30.6' LT	-	34.87'
9	102+85.89	30.7' LT	-	35.49'
10	102+82.02	57.0' LT	-	33.27'
11	102+82.89	42.0' LT	-	35.21'
12	102+85.47	40.8' LT	-	35.59'
13	102+86.17	24.0' LT	-	37.23'

DETAIL 4 SPOT GRADES				
POINT	STATION	OFFSET	ELEV. 1	ELEV. 2
1	101+56.17	26.6' RT	30.80'	31.29'
2	101+76.19	21.4' RT	31.71'	32.21'
3	101+83.50	18.0' RT	32.01'	-
4	101+89.50	18.0' RT	32.23'	-
5	101+93.50	18.6' RT	32.37'	32.62'
6	101+99.24	24.0' RT	32.58'	32.83'
7	102+00.00	27.9' RT	32.67'	-
8	102+00.00	33.9' RT	32.80'	-
9	300+46.78	45.4' RT	32.91'	33.16'
10	300+73.66	50.2' RT	33.34'	33.94'
11	101+89.50	27.9' RT	-	32.725'
12	101+89.50	33.9' RT	-	32.28'
13	300+47.65	53.9' RT	-	32.80'
14	101+83.50	27.9' RT	-	32.605'
15	101+83.50	33.9' RT	-	32.725'
16	300+48.65	63.8' RT	-	32.89'
17	300+74.96	60.4' RT	-	34.07'

DETAIL 3 SPOT GRADES				
POINT	STATION	OFFSET	ELEV. 1	ELEV. 2
1	103+80.09	29.0' LT	39.15'	39.65'
2	103+88.31	28.6' LT	39.54'	-
3	103+94.48	28.2' LT	39.84'	-
4	104+04.79	28.4' LT	40.33'	40.58'
5	104+09.19	31.4' LT	40.39'	-
6	104+11.55	37.3' LT	40.21'	-
7	104+11.91	45.3' LT	39.84'	40.30'
8	103+88.64	36.1' LT	-	40.10'
9	103+94.86	35.9' LT	-	40.40'
10	104+03.86	35.4' LT	-	40.54'
11	103+80.71	40.4' LT	-	39.76'
12	103+88.82	40.2' LT	-	40.18'
13	103+95.07	40.0' LT	-	40.48'
14	104+04.13	39.7' LT	-	40.62'
15	104+04.37	45.7' LT	-	39.84'
16	104+38.73	42.6' LT	40.76'	41.24'
17	104+38.56	31.6' LT	41.59'	-
18	104+44.39	25.8' LT	42.29'	-
19	104+56.61	24.4' LT	42.83'	43.25'
20	104+45.98	41.8' LT	-	41.95'
21	104+45.25	36.4' LT	-	42.20'
22	104+48.12	32.1' LT	-	42.45'
23	104+57.56	35.4' LT	-	43.22'

DETAIL 5 SPOT GRADES				
POINT	STATION	OFFSET	ELEV. 1	ELEV. 2
1	300+60.82	20.3' LT	36.21'	36.76'
2	300+43.87	13.5' LT	35.50'	35.92'
3	102+58.92	33.0' RT	34.95'	-
4	102+59.53	27.0' RT	35.09'	-
5	102+60.84	23.0' RT	34.83'	35.24'
6	102+67.03	18.3' RT	35.06'	35.47'
7	102+71.03	18.0' RT	35.20'	-
8	102+77.07	18.0' RT	35.39'	-
9	102+87.07	18.0' RT	35.79'	36.21'
10	102+71.03	26.8' RT	-	35.89'
11	102+71.00	32.8' RT	-	35.77'
12	102+77.03	26.8' RT	-	35.89'
13	102+77.03	26.7' RT	-	36.01'
14	300+43.81	28.7' LT	-	36.99'
15	300+34.48	28.6' LT	-	36.21'
16	102+86.99	36.9' RT	-	36.58'

DETAIL 6

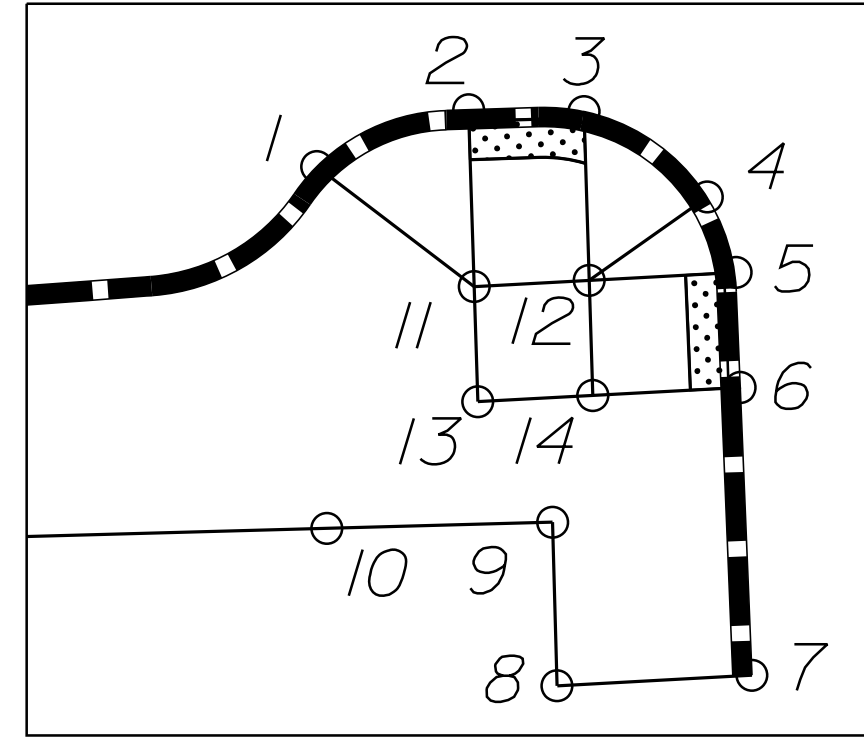

DETAIL 4

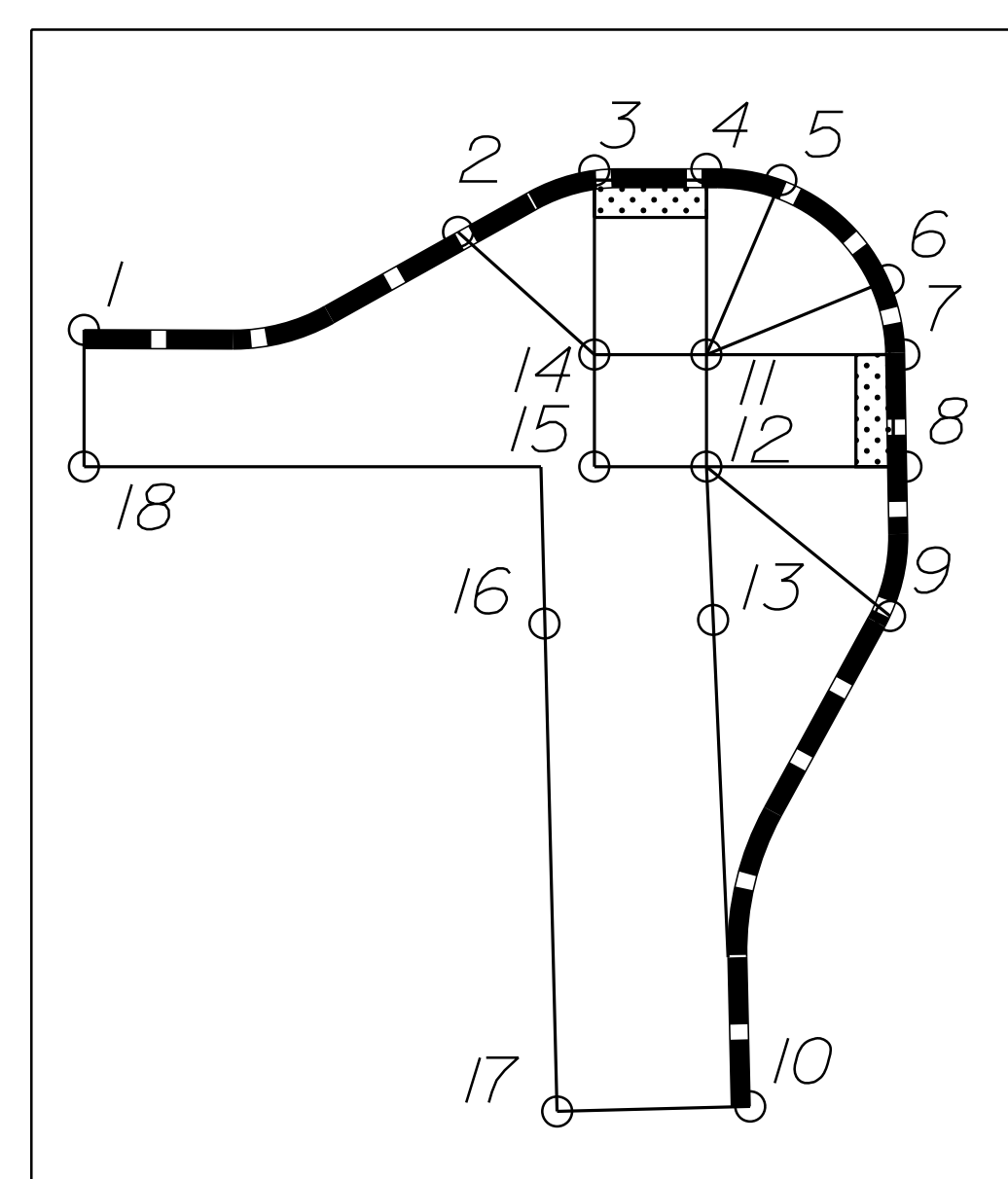

DETAIL 5

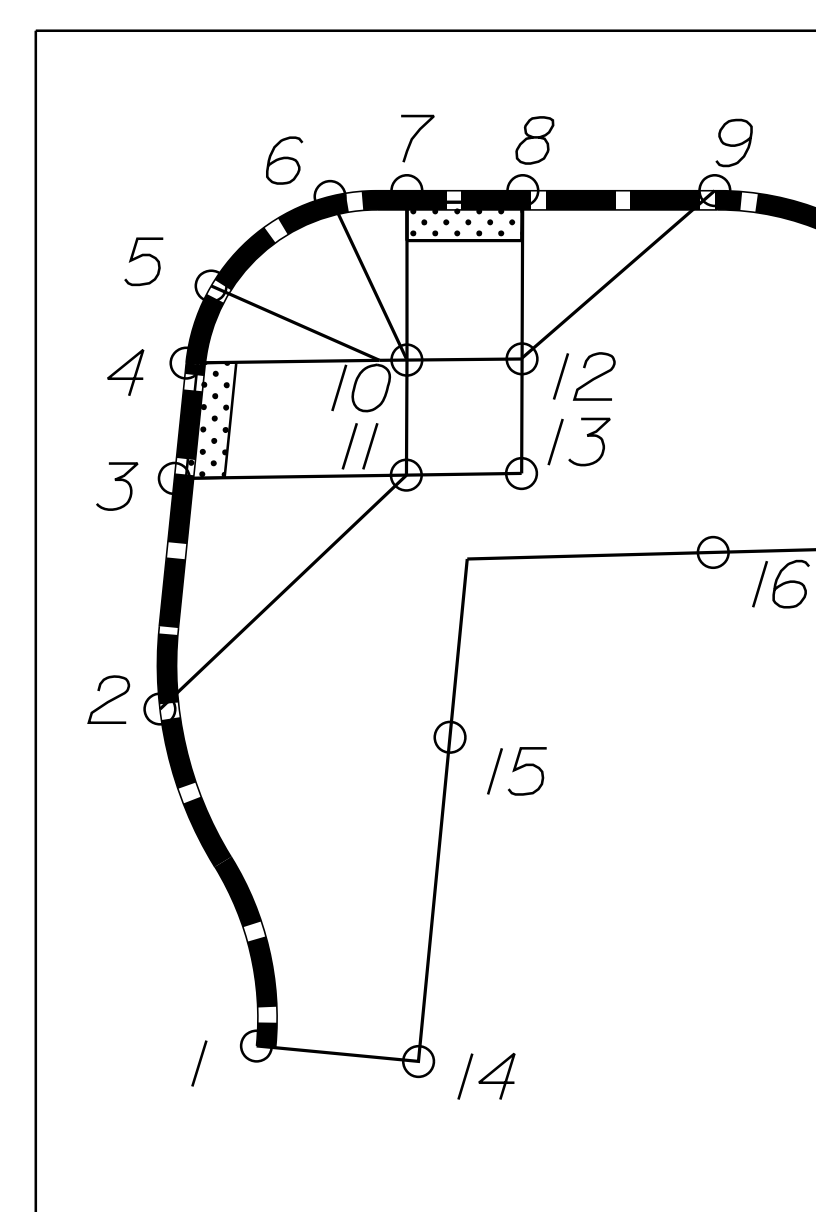

DETAIL 7

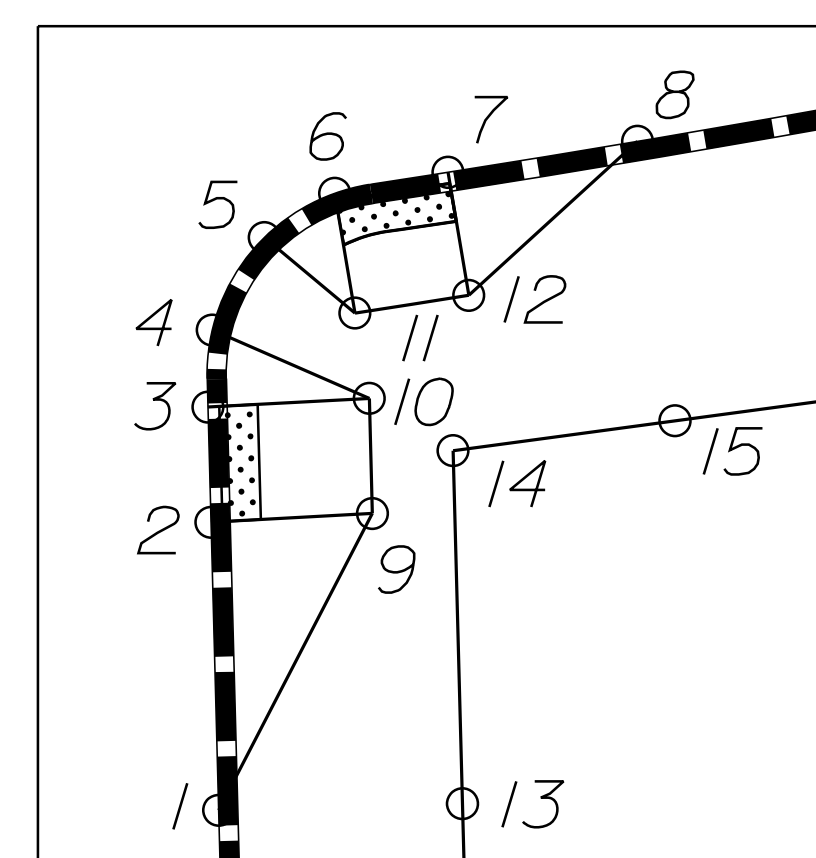

DETAIL 6 SPOT GRADES				
POINT	STATION	OFFSET	ELEV. 1	ELEV. 2
1	103+68.49	25.0' RT	39.60'	40.18'
2	103+77.38	20.0' RT	39.99'	-
3	103+85.37	17.8' RT	40.27'	-
4	103+95.00	20.7' RT	40.74'	40.99'
5	103+97.00	23.5' RT	40.96'	-
6	103+98.02	27.6' RT	41.21'	-
7	200+35.16	16.3' RT	41.88'	42.11'
8	200+50.44	26.3' RT	-	42.28'
9	200+41.92	26.3' RT	-	41.55'
10	103+76.32	38.8' RT	-	40.55'
11	103+84.81	26.9' RT	-	40.66'
12	103+90.65	27.2' RT	-	40.92'
13	103+84.45	33.0' RT	-	40.84'
14	103+90.25	33.2' RT	-	41.04'

DETAIL 7 SPOT GRADES				
POINT	STATION	OFFSET	ELEV. 1	ELEV. 2
1	200+49.15	20.9' LT	43.47'	44.05'
2	200+34.14	20.9' LT	42.90'	-
3	104+34.25	30.2' RT	42.69'	-
4	104+35.02	26.3' RT	42.57'	42.98'
5	104+38.32	21.9' RT	42.55'	42.97'
6	104+42.21	20.2' RT	42.72'	-
7	104+48.09	20.0' RT	43.01'	-
8	104+57.89	20.0' RT	43.50'	44.00'
9	104+41.78	37.0' RT	-	43.35'
10	104+42.50	31.0' RT	-	43.15'
11	104+42.43	26.5' RT	-	42.72'
12	104+48.27	26.5' RT	-	43.01'
13	200+49.49	33.7' LT	-	44.18'
14	104+46.27	34.4' RT	-	43.28'
15	104+57.54	34.7' RT	-	44.14'

PLS OR PE

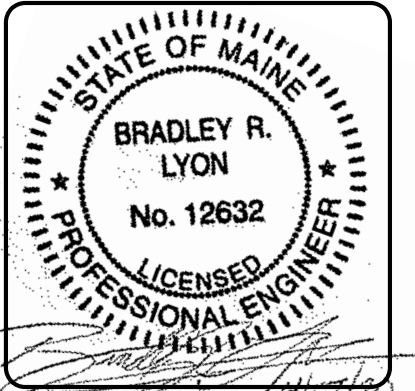

DESIGNED	CHECKED
NLS	BRL

1 NLS 04/17/20 100% FINAL CONTRACT PLANS
 REV. BY: DATE: STATUS:
 THIS PLAN SHALL NOT BE MODIFIED WITHOUT WRITTEN PERMISSION FROM SEBAGO TECHNICS, INC. ANY ALTERATIONS, AUTHORIZED OR OTHERWISE, SHALL BE AT THE USER'S SOLE RISK AND WITHOUT LIABILITY TO SEBAGO TECHNICS, INC.

SEBAGO
 TECHNICS
 WWW.SEBAGOTECHNICS.COM
 75 John Roberts Rd.
 Suite 4
 South Portland, ME 04106
 Tel. 207-209-2100

CURB PLAN
 OF
 CONGRESS STREET
 OFF-SITE IMPROVEMENTS
 PORTLAND, MAINE
 FOR:
 MAINE MEDICAL CENTER
 22 BRANHALL STREET
 PORTLAND, ME 04102

PROJECT NO.	SCALE
15466	1" = 20'

DETAIL 8

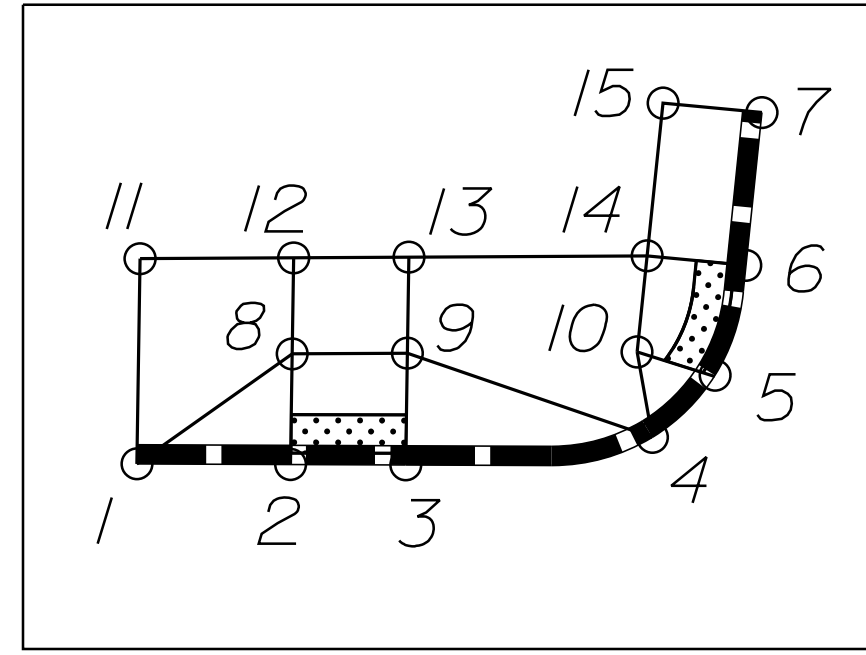

DETAIL 8 SPOT GRADES				
POINT	STATION	OFFSET	ELEV. 1	ELEV. 2
1	105+99.28	19.7' LT	50.64'	50.95'
2	106+07.39	19.9' LT	51.07'	-
3	106+13.47	20.0' LT	51.39'	-
4	106+26.48	21.6' LT	52.10'	52.43'
5	106+29.72	24.8' LT	52.28'	-
6	106+31.29	30.6' LT	52.26'	-
7	106+32.14	38.6' LT	51.92'	52.34'
8	106+07.34	25.6' LT	-	51.37'
9	106+13.44	25.7' LT	-	51.67'
10	106+25.61	26.0' LT	-	52.30'
11	105+99.13	30.4' LT	-	51.09'
12	106+07.29	30.6' LT	-	51.47'
13	106+13.42	30.8' LT	-	51.77'
14	106+26.09	31.0' LT	-	52.20'
15	106+26.85	39.0' LT	-	52.05'

DETAIL 13

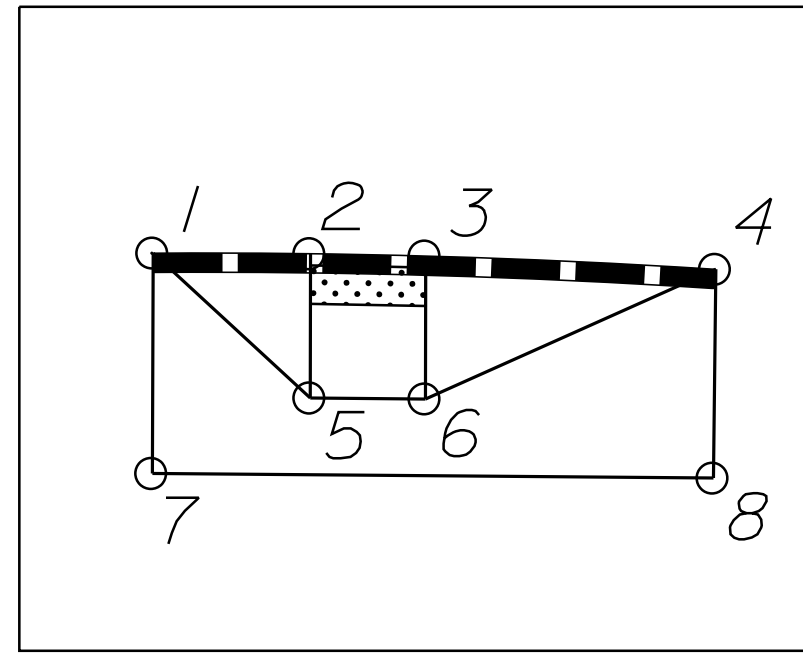

DETAIL 13 SPOT GRADES				
POINT	STATION	OFFSET	ELEV. 1	ELEV. 2
1	111+14.20	24.6' RT	77.04'	77.78'
2	111+22.22	24.6' RT	77.43'	-
3	111+28.20	24.8' RT	77.72'	-
4	111+43.32	25.6' RT	78.45'	79.15'
5	111+22.17	32.2' RT	-	78.01'
6	111+28.17	32.2' RT	-	78.30'
7	111+13.92	36.1' RT	-	78.00'
8	111+43.15	36.4' RT	-	79.34'

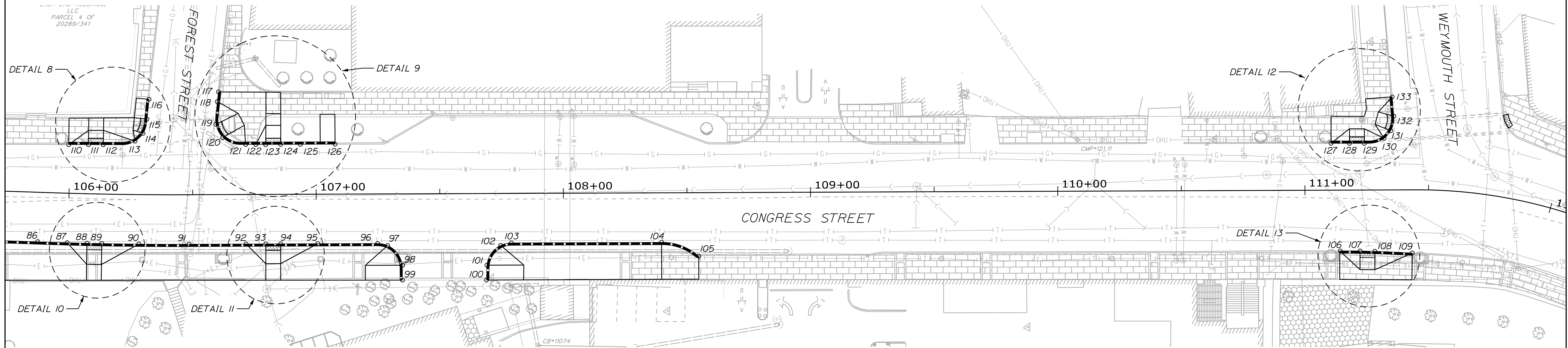
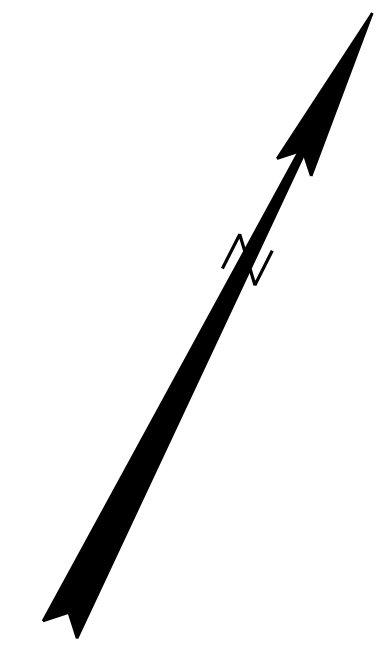

DETAIL 10

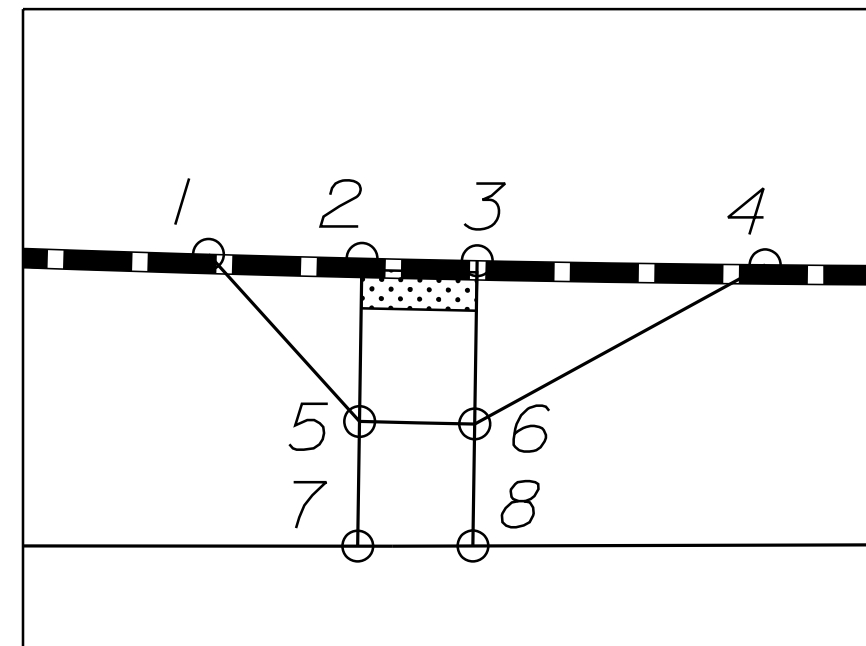

DETAIL 10 SPOT GRADES				
POINT	STATION	OFFSET	ELEV. 1	ELEV. 2
1	105+99.81	20.0' RT	50.88'	51.46'
2	106+07.71	20.0' RT	51.28'	-
3	106+13.63	20.0' RT	51.60'	-
4	106+28.43	20.0' RT	52.39'	52.97'
5	106+07.78	28.5' RT	-	51.94'
6	106+13.67	28.5' RT	-	52.26'
7	106+07.83	35.0' RT	-	52.01'
8	106+13.69	34.9' RT	-	52.33'

DETAIL 11

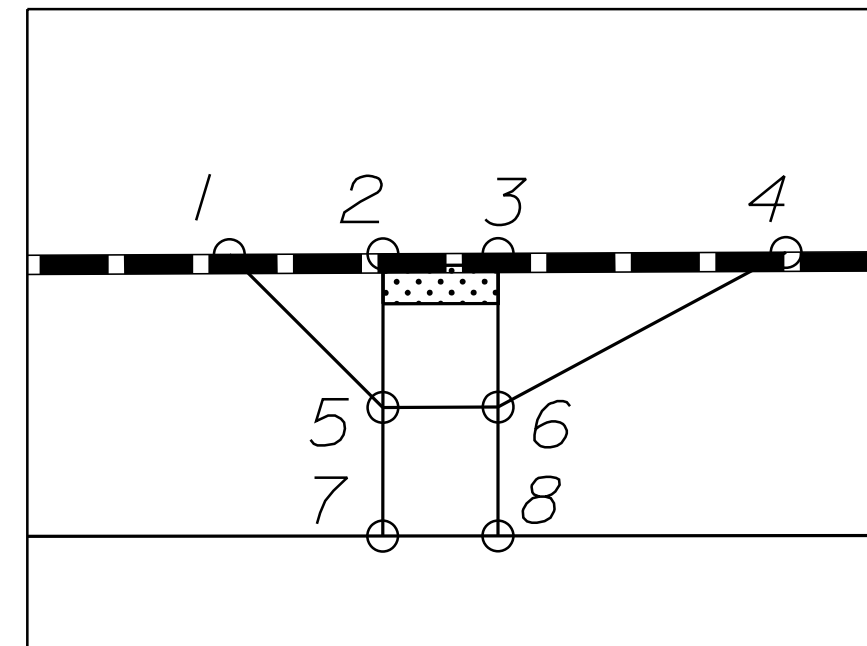

DETAIL 11 SPOT GRADES				
POINT	STATION	OFFSET	ELEV. 1	ELEV. 2
1	106+71.55	20.0' RT	54.70'	55.28'
2	106+79.55	20.0' RT	55.12'	-
3	106+85.55	20.0' RT	55.44'	-
4	107+00.56	20.0' RT	56.25'	56.83'
5	106+79.51	28.0' RT	-	55.78'
6	106+85.51	28.0' RT	-	56.10'
7	106+79.48	34.7' RT	-	55.84'
8	106+85.48	34.7' RT	-	56.17'

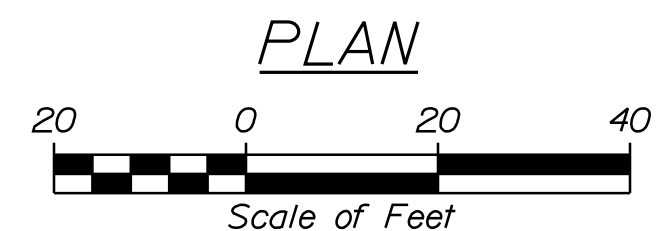

PLS OR PE

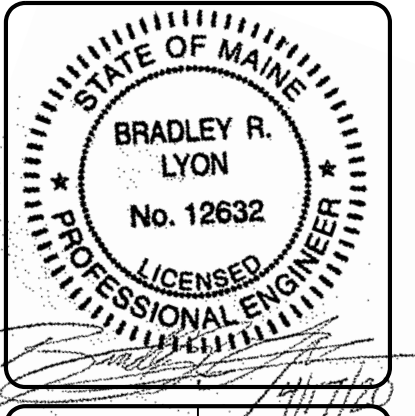

DESIGNED	CHECKED
NLS	BRL

1 NLS 04/17/20 100% FINAL CONTRACT PLANS
 REV. BY: DATE: STATUS:
 THIS PLAN SHALL NOT BE MODIFIED WITHOUT WRITTEN PERMISSION FROM SEBAGO TECHNICS, INC. ANY ALTERATIONS, AUTHORIZED OR OTHERWISE, SHALL BE AT THE USER'S SOLE RISK AND WITHOUT LIABILITY TO SEBAGO TECHNICS, INC.

SEBAGO
 TECHNICS
 WWW.SEBOGOTECHNICS.COM
 75 John Roberts Rd.
 South Portland, ME 04106
 Tel. 207-209-2100

CURB PLAN
 OF
 CONGRESS STREET
 OFF-SITE IMPROVEMENTS
 PORTLAND, MAINE
 FOR:
 MAINE MEDICAL CENTER
 22 BRANHALL STREET
 PORTLAND, ME 04102

PROJECT NO.	SCALE
15466	1" = 20'

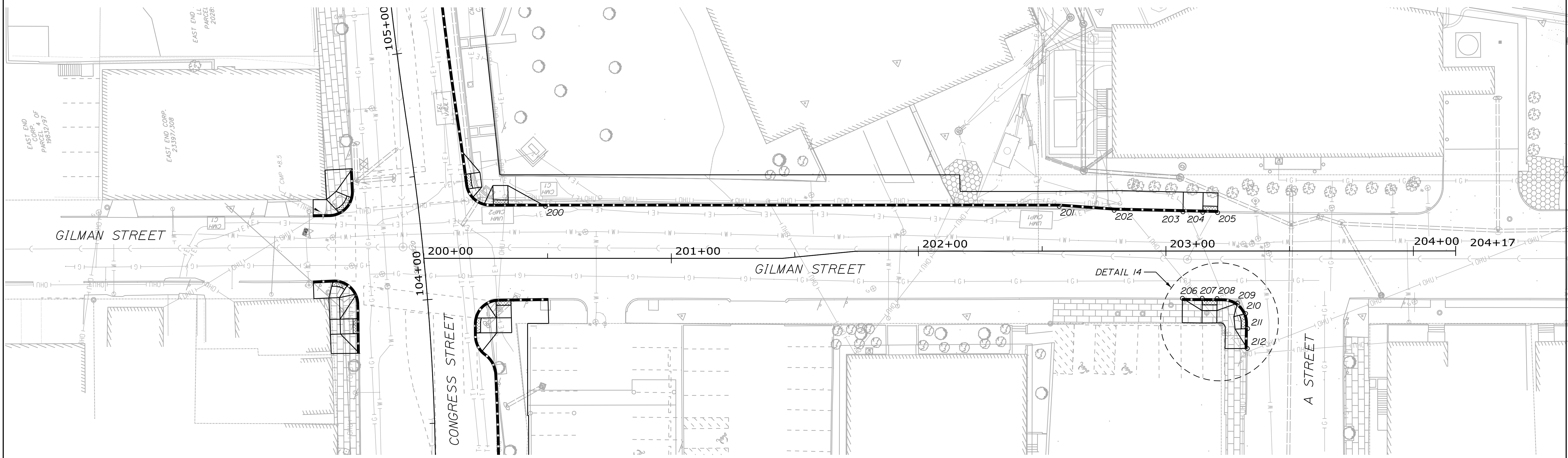
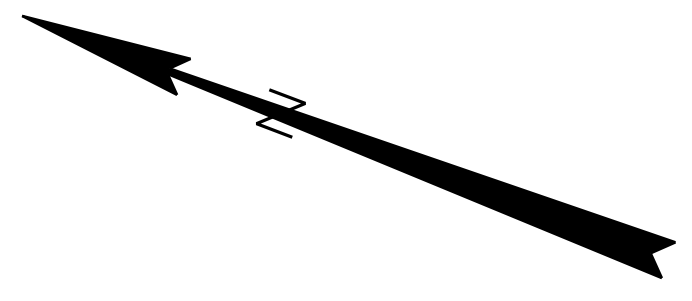

DETAIL 1

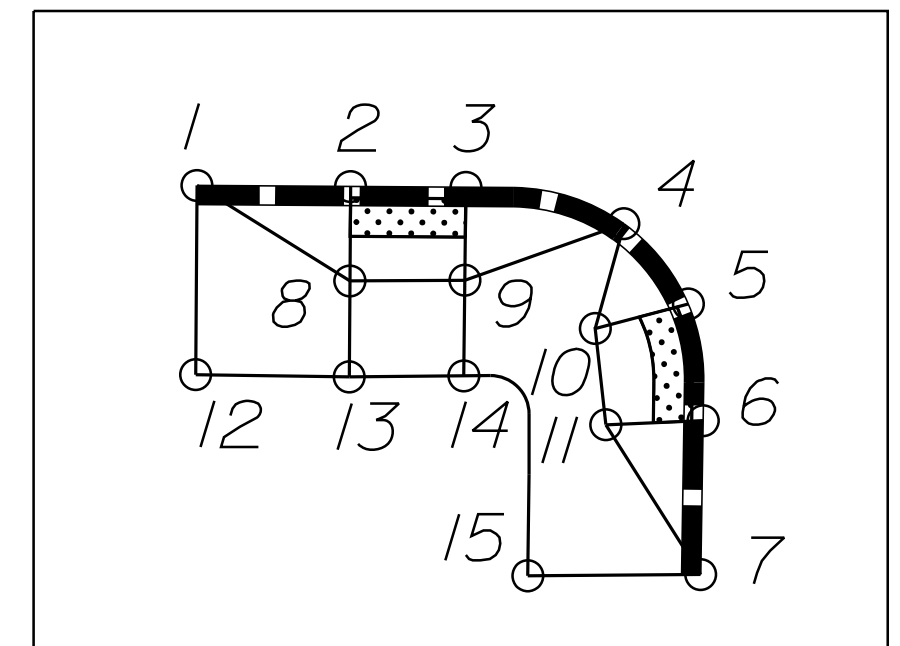

DETAIL 14 SPOT GRADES				
POINT	STATION	OFFSET	ELEV. 1	ELEV. 2
1	203+06.67	19.1' RT	61.00'	61.25'
2	203+14.65	19.1' RT	61.58'	-
3	203+20.68	19.2' RT	62.01'	-
4	203+28.91	21.1' RT	62.51'	62.76'
5	203+32.24	25.3' RT	62.39	-
6	203+33.03	31.3' RT	62.57'	-
7	203+32.89	39.3' RT	62.10'	62.23'
8	203+14.63	24.0' RT	61.64'	-
9	203+20.62	24.0' RT	62.07'	-
10	203+27.41	26.5' RT	-	62.57'
11	203+27.96	31.5' RT	-	62.39'
12	203+06.59	28.9' RT	-	61.13'
13	203+14.59	29.0' RT	-	61.54'
14	203+20.56	28.9' RT	-	61.97'
15	203+23.89	39.3' RT	-	61.39'

CONTROL POINTS FOR CONGRESS STREET		
POINT	STATION	OFFSET
200	200+49.14	21.0' LT
201	202+56.89	18.1' LT
202	202+79.09	16.5' LT
203	203+06.91	15.8' LT
204	203+14.91	15.6' LT
205	203+20.91	15.5' LT
206	203+06.67	19.1' RT
207	203+14.65	19.1' RT
208	203+20.68	19.2' RT
209	203+28.91	21.1' RT
210	203+32.24	25.3' RT
211	203+33.03	31.3' RT
212	203+32.89	39.3' RT

NEW VERTICAL CURB TYPE 1		
POINT TO POINT	RADIUS (FT)	LENGTH (LF)
200 TO 201	-	207.6
201 TO 202	-	22.2
202 TO 203	-	27.8
204 TO 205 (FLUSH)	-	6
207 TO 208 (FLUSH)	-	6
SHEET SUBTOTAL (LF)		270

NEW TERMINAL CURB TYPE 1		
POINT TO POINT	RADIUS (FT)	LENGTH (LF)
203 TO 204	-	8
206 TO 207	-	8
211 TO 212	-	8
SHEET SUBTOTAL (LF)		24

NEW VERTICAL CURB TYPE 1 - CIRCULAR		
POINT TO POINT	RADIUS (FT)	LENGTH (LF)
210 TO 211 (FLUSH)	10	6
SHEET SUBTOTAL (LF)		6

NEW TERMINAL CURB TYPE 1 - CIRCULAR		
POINT TO POINT	RADIUS (FT)	LENGTH (LF)
208 TO 209	10	8
209 TO 210	10	4
SHEET SUBTOTAL (LF)		12

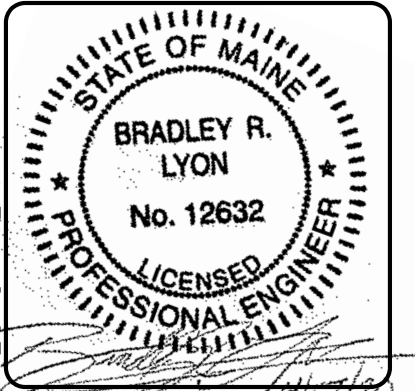
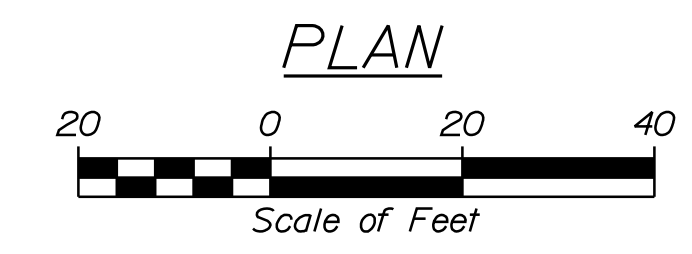

DESIGNED	CHECKED
NLS	BRL
1 NLS 04/17/20 100% FINAL CONTRACT PLANS	
REV. BY: DATE: STATUS:	
THE PLAN SHALL NOT BE MODIFIED WITHOUT WRITTEN PERMISSION FROM SEBAGO TECHNICS, INC. ANY ALTERATIONS, AUTHORIZED OR OTHERWISE, SHALL BE AT THE USER'S SOLE RISK AND WITHOUT LIABILITY TO SEBAGO TECHNICS, INC.	

SEBAGO
TECHNICS
WWW.SEBAGOTECHNICS.COM
75 John Roberts Rd.
South Portland, ME 04106
Tel. 207-209-2100

CURB PLAN
OF
GILMAN STREET
OFF-SITE IMPROVEMENTS
FOR:
MAINE MEDICAL CENTER
22 BRANHALL STREET
PORTLAND, ME 04102

PROJECT NO.	SCALE
15466	1" = 20'

ST. JOHN ST. @ CONGRESS ST. GENERAL
TRAFFIC NOTES / SCOPE OF WORK

ST. JOHN ST. @ CONGRESS ST. SIGNAL TIMINGS

	Phase 1	Phase 2	Phase 3	Phase 4	Phase 5	Phase 6	Phase 7	Phase 8
Min Green	8.0	8.0	8.0	8.0	8.0	8.0	-	8.0
Extension	3.0	3.0	3.0	3.0	3.0	3.0	-	3.0
Max I	25.0	30.0	20.0	25.0	15.0	45.0	-	10.0
Max II	30.0	35.0	25.0	30.0	20.0	50.0	-	15.0
Veh. Clear	3.0	3.0	3.0	3.0	3.0	3.0	-	3.0
Red Clear	2.0	2.0	2.0	2.0	2.0	2.0	-	2.0
Walk	-	7.0	-	7.0	-	9.0	-	7.0
Ped Clear	-	12.0	-	12.0	-	13.0	-	16.0
Recall	-	SOFT	-	-	-	SOFT	-	-
Flash	R	Y	R	R	R	Y	-	R
Dual Entry	OFF	ON	OFF	ON	OFF	ON	OFF	ON
Detector Memory	OFF	OFF	OFF	OFF	OFF	OFF	-	OFF

SIGNAL TIMING NOTES:

- EMERGENCY FLASH ONLY. SIGNAL TO OPERATE ON COLORS AT ALL TIMES.
- SIGNAL SHALL DISPLAY A 3 SECOND ALL RED AFTER CONFLICT FLASH.

- THE EXISTING SIGNAL CABINET LOCATED ON THE NW CORNER OF ST. JOHN ST. @ CONGRESS ST. CURRENTLY CONTROLS BOTH THE ST. JOHN ST. AND THE VALLEY ST. @ CONGRESS ST. SIGNALIZED INTERSECTIONS. THROUGH THE REMOVAL OF THE TRAFFIC SIGNAL AT VALLEY STREET CAPACITY WILL BE CREATED IN THE TRAFFIC SIGNAL CABINET TO ALLOW FOR THE EXISTING EXCLUSIVE PEDESTRIAN PHASING TO BE CHANGED TO CONCURRENT PEDESTRIAN PHASING.
- IT IS THE INTENT FOR THIS INTERSECTION TO RUN IN A "FREE" MODE OF OPERATION FOLLOWING THE REMOVAL OF THE VALLEY ST. SIGNAL AND PROGRAMMED TO THE PARAMETERS OUTLINED IN THIS PLAN.
- THE SIGNAL CABINET SHALL BE REWIRED AND REPROGRAMMED AS NECESSARY TO ALLOW FOR CONCURRENT PEDESTRIAN PHASING BY UTILIZING THE TIMING AND PHASE SEQUENCE / COMPATABILITY OUTLINED ON THIS PLAN.
- THE EXISTING APS BUTTONS SHALL BE UTILIZED AT ST. JOHN ST. TO THE MAXIMUM EXTENT POSSIBLE. IF A BUTTON IS FOUND TO BE MALFUNCTIONING AND CANNOT BE REPAIRED IT SHALL BE REPLACED WITH A FULL CAMPBELL ADVISOR SERIES APS ASSEMBLY PER THE CITY OF PORTLAND'S TRAFFIC SIGNAL POLICY AND GUIDANCE MANUAL DATED DECEMBER 2019.
- ALL APS BUTTONS AT ST. JOHN ST. SHALL BE REPROGRAMMED (OR PROGRAMMED IF A NEW APS ASSEMBLY IS PROVIDED) WITH AUDIBLE MESSAGES DURING THE WALK PHASE AS FOLLOWS: "CONGRESS STREET (OR ST. JOHN STREET). WALK SIGN IS ON TO CROSS CONGRESS STREET (OR ST. JOHN STREET)" THE AUDIBLE PUSH BUTTON IDENTIFICATION INFORMATION MESSAGE USED DURING THE NON-WALK PHASE SHALL BE AS FOLLOWS: "WAIT TO CROSS CONGRESS STREET (OR ST. JOHN STREET)"
- LOCATOR TONES FOR ALL PUSH BUTTONS ARE REQUIRED. THEIR VOLUME IS TO BE AUTOMATICALLY ADJUSTED TO AMBIENT NOISE LEVELS.
- A COPY OF AS-BUILT PLANS INCLUDING A WIRING DIAGRAM AND MANUALS FOR ANY NEW EQUIPMENT PROVIDED SHALL BE LEFT IN THE CABINET.
- THE EXISTING SIGNAL SHALL BE OPERATIONAL THROUGHOUT THE CONSTRUCTION PERIOD. IF CONSTRUCTION SEQUENCING DOES NOT ALLOW FOR THIS TO BE POSSIBLE, THE CONTRACTOR SHALL BE RESPONSIBLE FOR SCHEDULING AND SUPERVISING TRAFFIC OFFICERS FOR CONTROLLING THE INTERSECTION. THE PORTLAND POLICE DEPARTMENT REQUIRES 48-HOUR NOTICE FOR ANY POLICE DETAIL ON SITE.

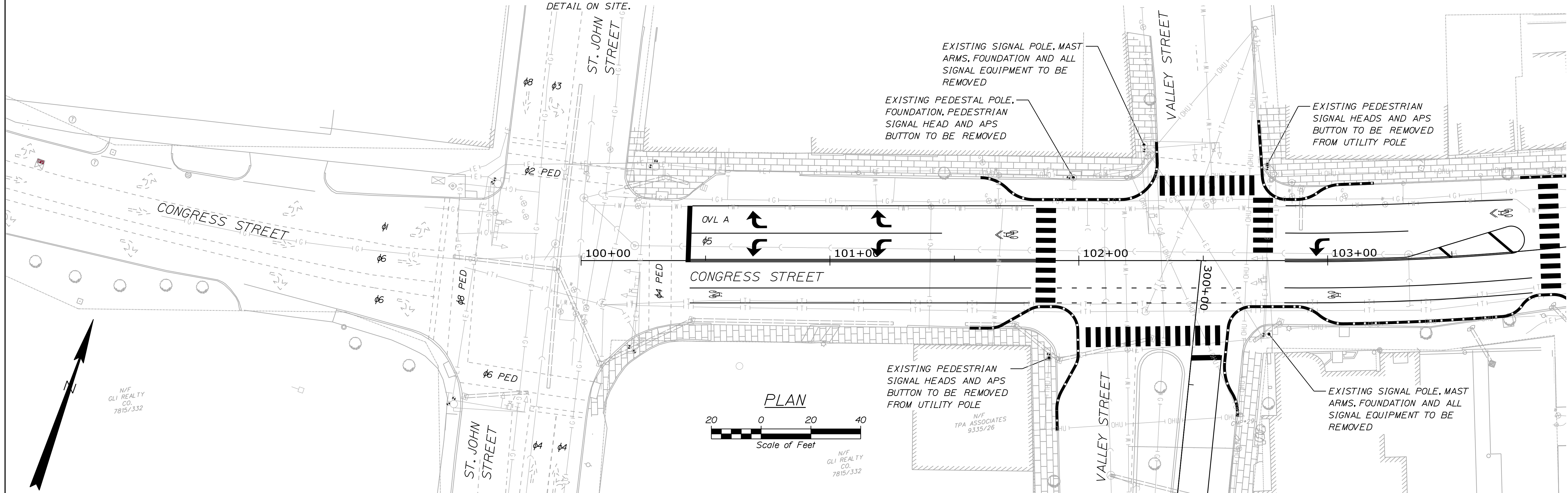

PHASING NOTES:

- PEDESTRIAN PHASE UPON PUSH BUTTON ACTIVATION ONLY
- TURNING MOVEMENTS NOT SUPPORTED BY AN ARROW INDICATION ARE SHOWN AS A HOLLOW ARROW.

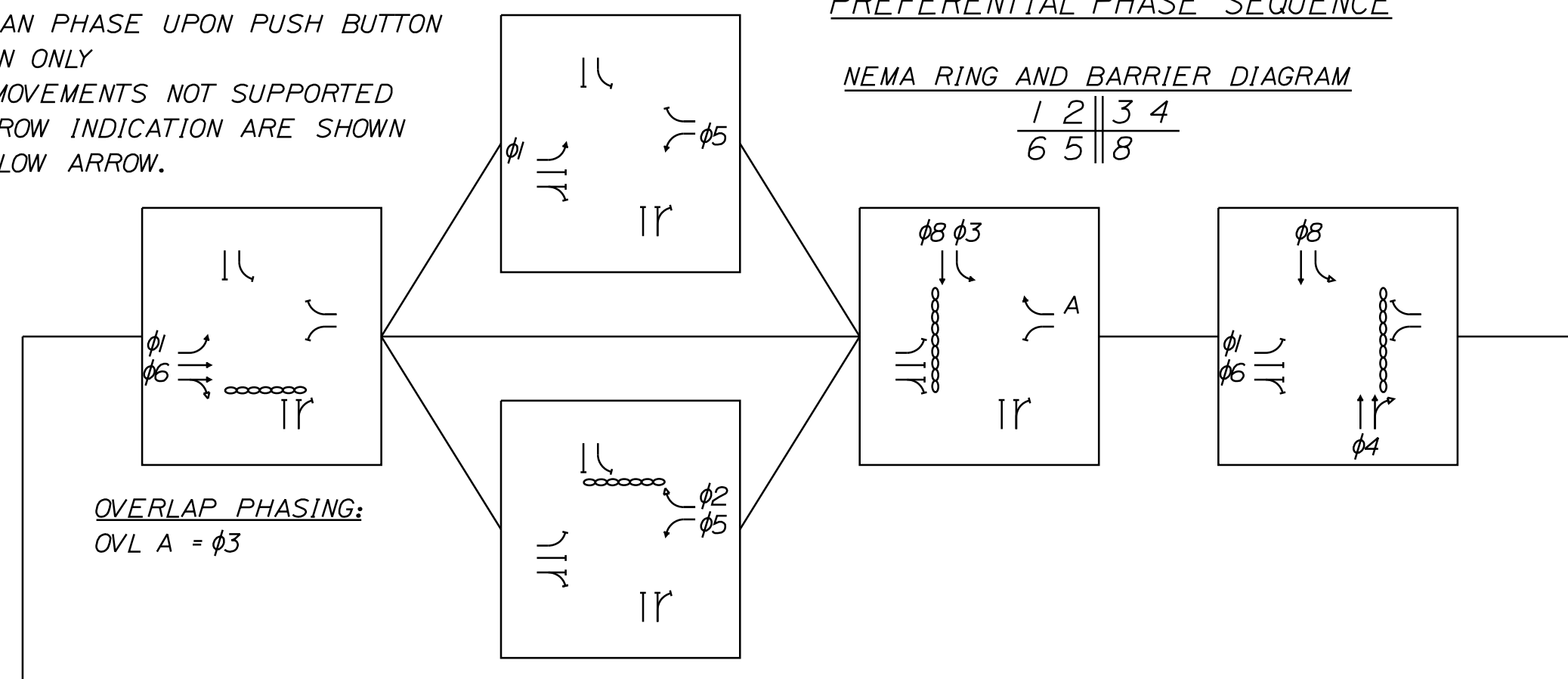

VALLEY ST. @ CONGRESS ST. GENERAL
TRAFFIC NOTES / SCOPE OF WORK

- PRIOR TO THE REMOVAL OF THE SIGNAL EQUIPMENT AT VALLEY STREET, THE INTERSECTION MUST BE PUT INTO A "FLASH" MODE OF OPERATIONS FOR A MINIMUM OF 30 DAYS, WITH CONGRESS STREET THRU MOVEMENTS TO FLASH YELLOW AND ALL OTHER OPPOSING MOVEMENTS TO FLASH RED. THE ST. JOHN STREET INTERSECTION SHALL RUN ON COLORS DURING THIS TIME.
- EXISTING FOUNDATIONS SHALL BE REMOVED TO THE MAXIMUM EXTENT FEASIBLE AND BACKFILLED WITH AGGREGATE BASE COURSE TYPE "B" GRAVEL OR OTHER SUITABLE MATERIAL APPROVED BY THE CITY OF PORTLAND. ALL SIDEWALK AREAS IMPACTED BY THE EXCAVATION SHALL BE REPAIRED AND REPLACED WITH THE BRICK OR CONCRETE MATERIAL THAT EXISTS TODAY, FOLLOWING THE CITY OF PORTLAND TECHNICAL STANDARDS MANUAL 1-11 OR 1-14 DETAILS.
- ALL UNDERGROUND SIGNAL WIRING SHALL BE REMOVED, WITH THE EXISTING COMMUNICATIONS AND CONDUIT TO BE ABANDONED IN PLACE.
- REMOVAL OF THE EXISTING TRAFFIC SIGNAL SHALL ONLY OCCUR AFTER A TRAFFIC CONTROL PLAN HAS BEEN SUBMITTED AND APPROVED BY THE CITY OF PORTLAND OUTLINING THE PHASING AND HOURS OF WORK.
- THE CITY OF PORTLAND SHALL HAVE FIRST SALVAGE RIGHTS TO ALL SIGNAL EQUIPMENT REMOVED.

PLS OR PE

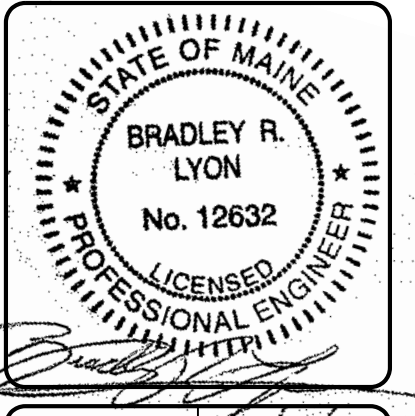

DESIGNED	CHECKED
BRL	BRL
2 BRL 04/26/20 UPDATED INCORRECT SIDE STREET REFERENCES	
1 BRL 04/17/20 100% FINAL CONTRACT PLANS	
REVIEWED:	DATE: STATUS:
THIS PLAN SHALL NOT BE MODIFIED WITHOUT WRITTEN PERMISSION FROM SEBAGO TECHNICS, INC. ANY ALTERATIONS AUTHORIZED OR OTHERWISE, SHALL BE AT THE USER'S SOLE RISK AND WITHOUT LIABILITY TO SEBAGO TECHNICS, INC.	

SEBAGO
TECHNICS
WWW.SEBAGOTECHNICS.COM
75 John Roberts Rd.
Suite 4
South Portland, ME 04106
Tel: 207-209-2100

TRAFFIC SIGNAL PLAN
OF
CONGRESS STREET
PORTLAND, MAINE
OFF-SITE IMPROVEMENTS
FOR:
MAINE MEDICAL CENTER
22 BRANHALL STREET
PORTLAND, ME 04102

PROJECT NO.	SCALE
15466	1" = 20'