

**EAST ELEVATION**  
 1/16" = 1'-0"  
 0' 4' 8' 16' 32'

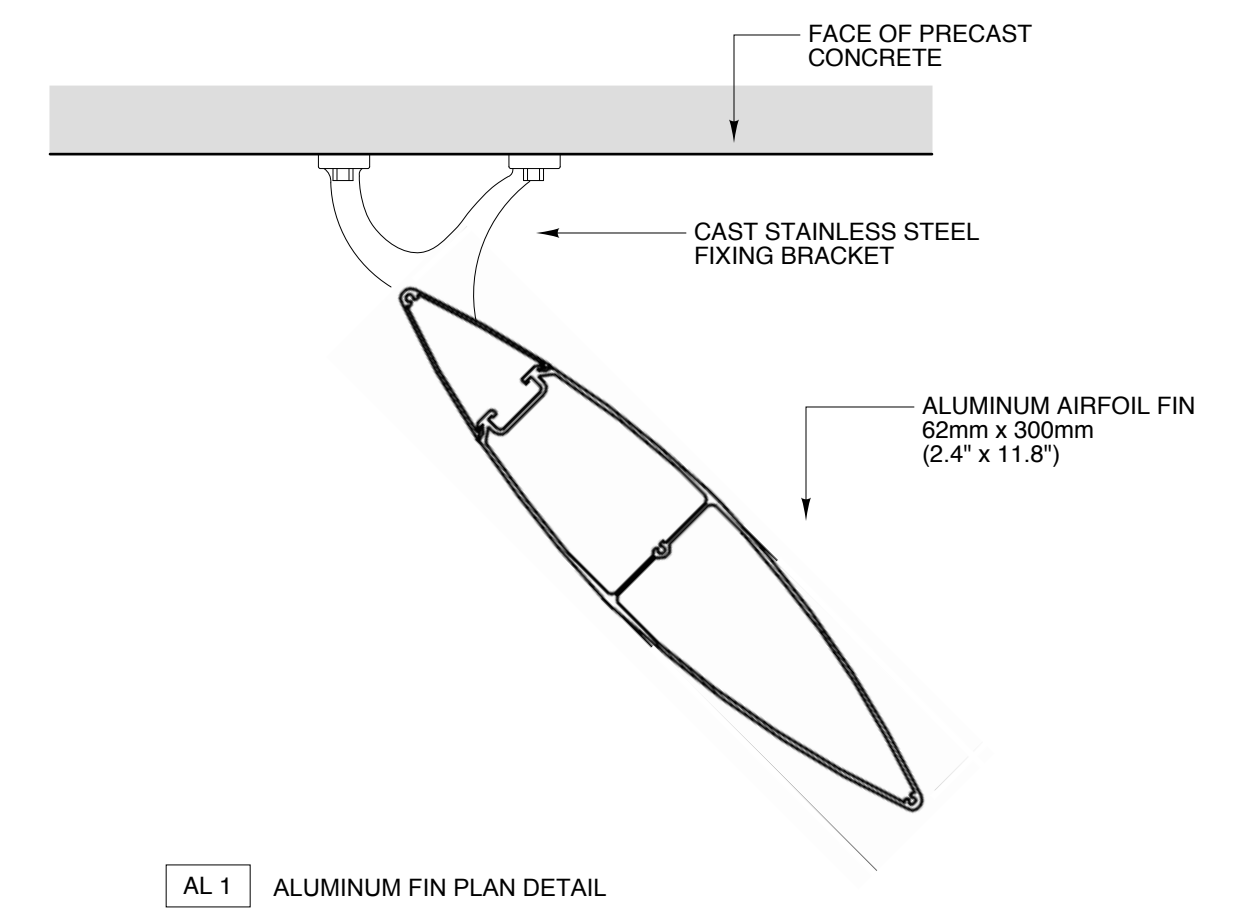

ST 1 SECURITY GRILLE DETAIL

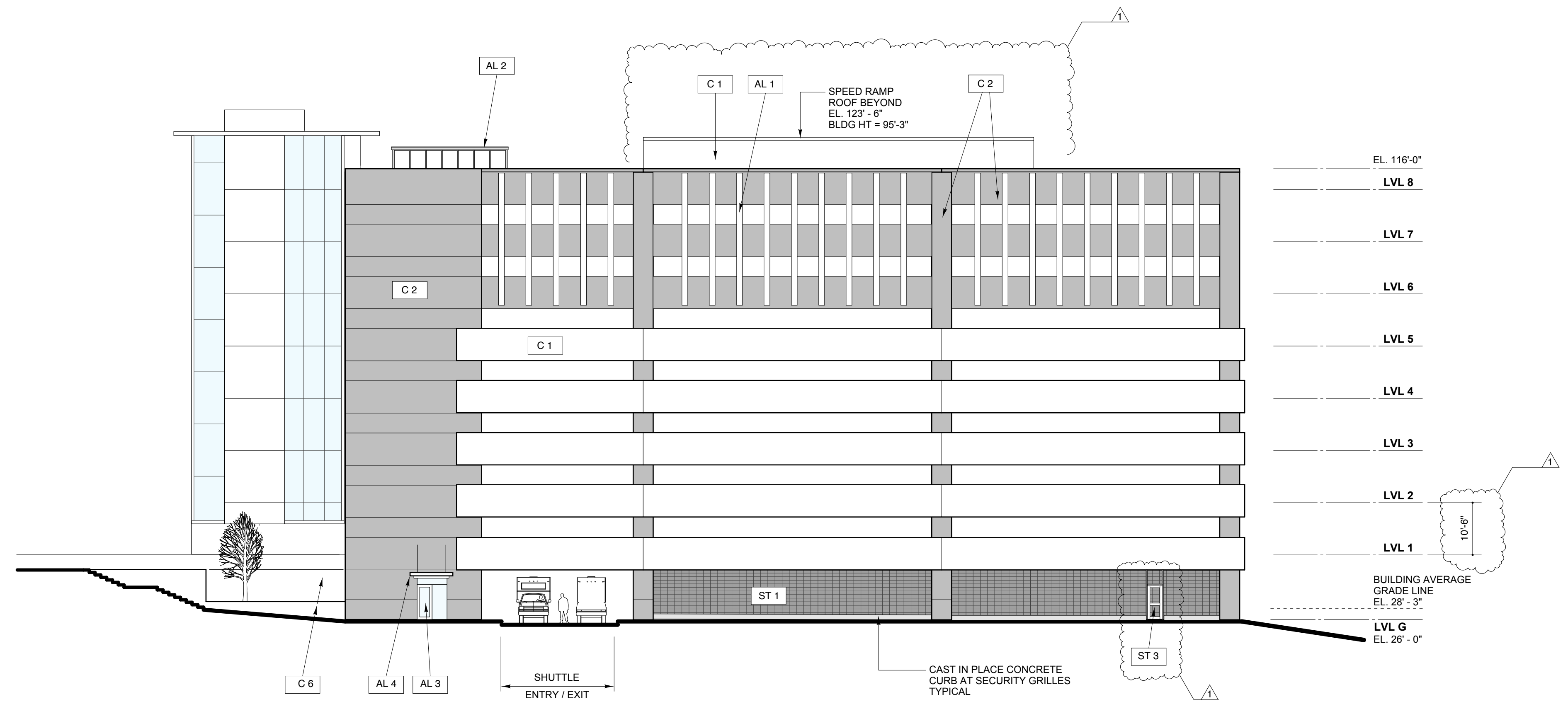

**NORTH ELEVATION**  
 1/16" = 1'-0"  
 0' 4' 8' 16' 32'

**EXTERIOR MATERIALS LEGEND**

AL 1	ALUMINUM LIGHT-CONTROL FIN ASSEMBLY
AL 2	ALUMINUM STOREFRONT FRAMED STAIR PENTHOUSE ENCLOSURE
AL 3	CURTAINWALL - CLEAR GLASS / CLEAR ANODIZED ALUMINUM FRAMING
AL 4	ALUMINUM ROOF EDGE TRIM
AL 5	ALUMINUM SIDING EQUIPMENT SCREEN
AL 6	ALUMINUM LOUVER
C 1	PRECAST CONCRETE : WHITE WITH LIGHT SANDBLAST
C 2	PRECAST CONCRETE : CHARCOAL GRAY WITH LIGHT SANDBLAST
C 3	PRECAST CONCRETE PROJECTING CORNICE
C 4	PRECAST CONCRETE COLUMNS : WHITE WITH LIGHT SANDBLAST
C 5	PRECAST CONCRETE SMOOTH WALL PANEL
C 6	CAST IN PLACE CONCRETE FOUNDATION / RETAINING WALL
ST 1	SECURITY ENCLOSURE GRILLE : PREFINISHED STEEL BAR GRATING
ST 2	PAINTED FLUSH HOLLOW METAL DOORS
ST 3	PAINTED WELDED TUBE STEEL STILE AND RAIL DOOR AND FRAME

THIS DRAWING IS AN INSTRUMENT OF SERVICE AND SHALL REMAIN THE PROPERTY OF BECKER STRUCTURAL ENGINEERS INC. IT SHALL NOT BE REPRODUCED, COPIED, LENT OR DISPOSED OF DIRECTLY OR INDIRECTLY FOR ANY PURPOSE OTHER THAN THAT FOR WHICH IT IS SPECIFICALLY PROVIDED AND MUST BE RETURNED TO BECKER STRUCTURAL ENGINEERS INC. ON COMPLETION OF WORK, IF REQUESTED.

NOT FOR CONSTRUCTION  
 LEVEL III SITE PLAN APPLICATION  
 6 / 22 / 18

Appr.	
Issued For	RESPONSE TO COMMENTS SUBMISSION
Date	7/24/18
Rev No	A

MMC ST. JOHN ST PG  
 PORTLAND, ME  
 BUILDING ELEVATIONS

Design	MMW	AS NOTED
Check	MMW	4/10/18
Check	MMW	4070.1

A 101