

CURB TYPE 1 ON CURVES

TYPE	RADIUS OF CURVE	LENGTH	STONE IS CUT OR CAST
1	0' TO 60' INCL.	4' MIN.	ARC TO FIT CURVE
	OVER 60' TO 160'	4' TO 6'	STRAIGHT PIECES

TYPICAL NEW AND RESET CURB INSTALLATION
N.T.S.

NOTE: AGGREGATE TYPES PER MDOT SECTION 304.02

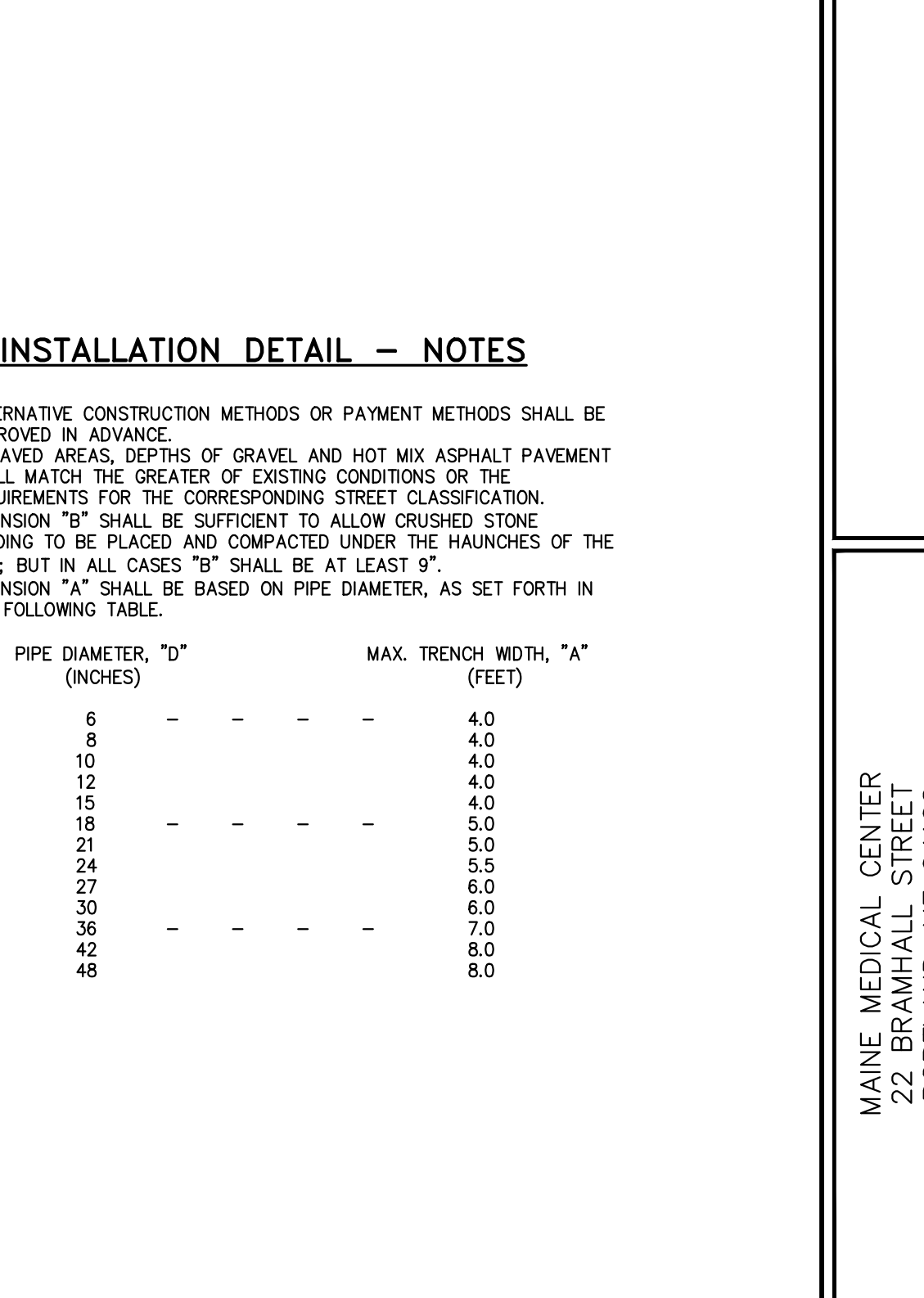
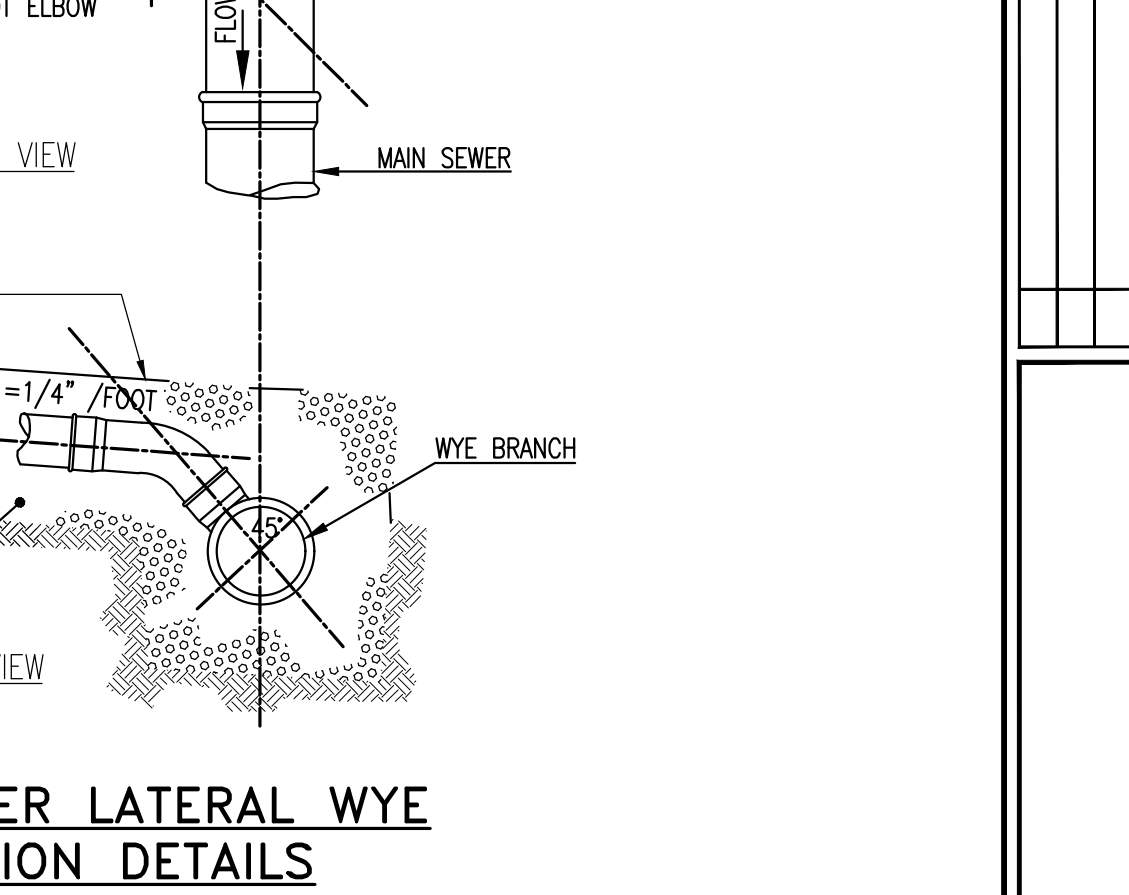
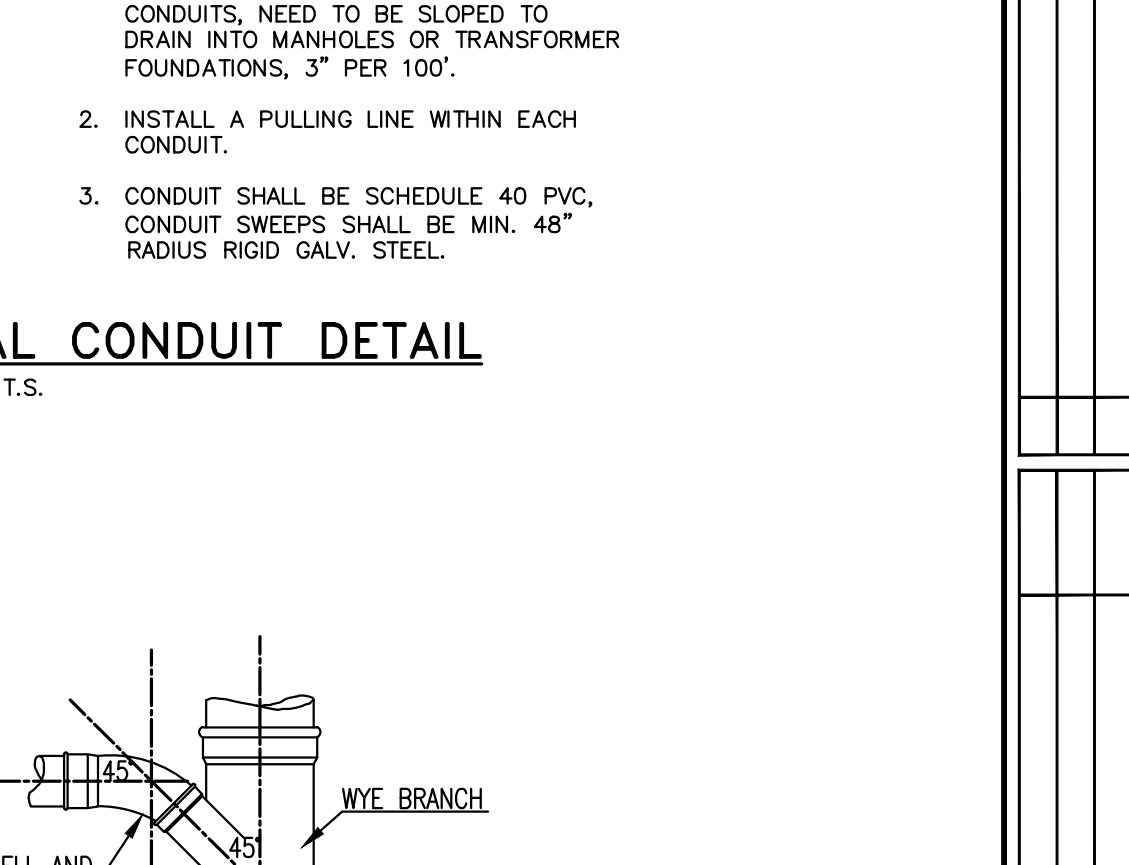
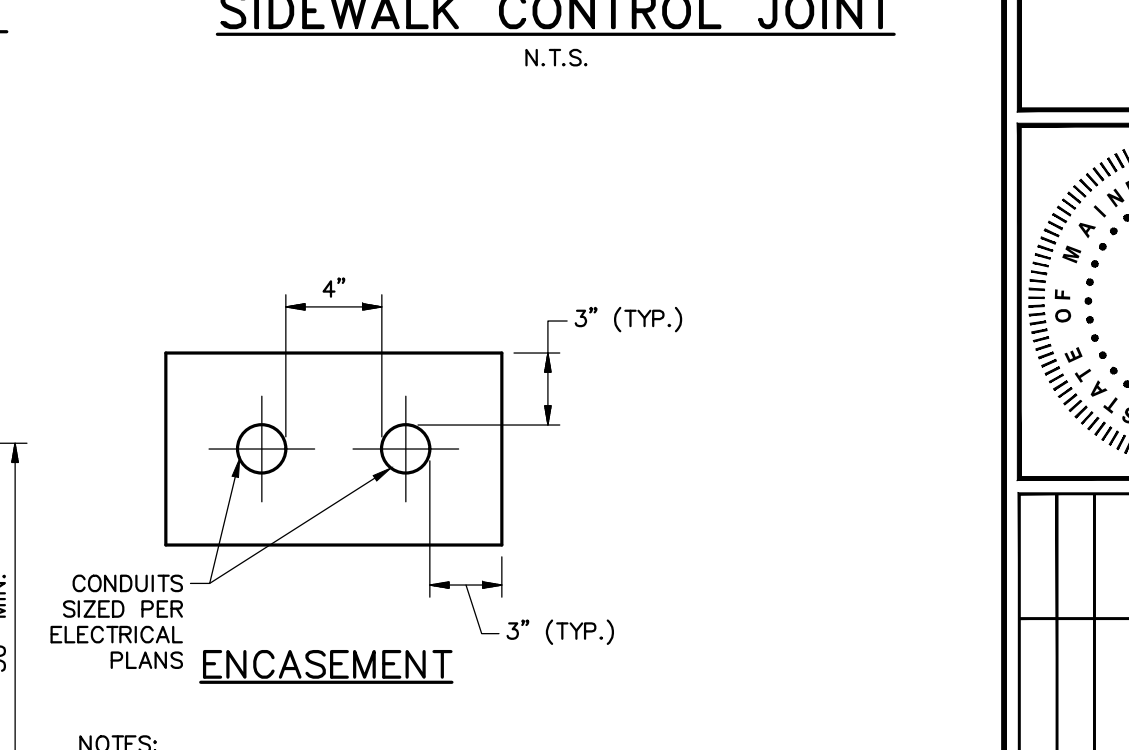
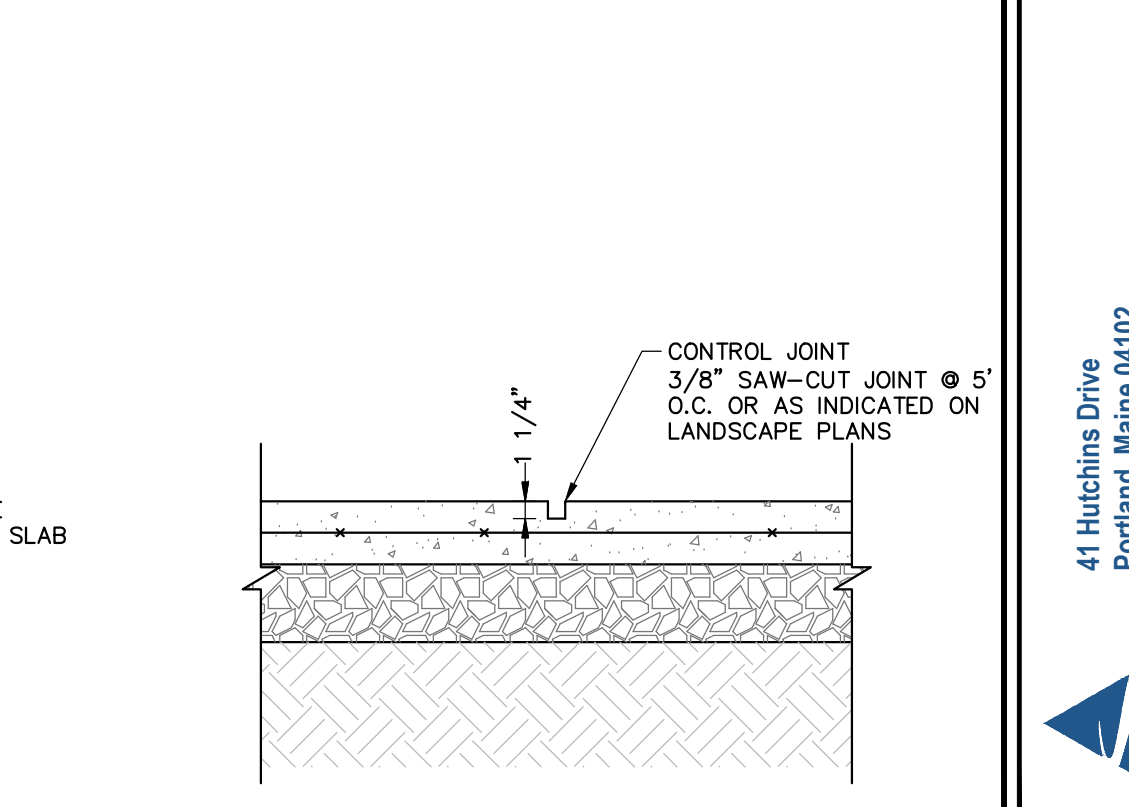
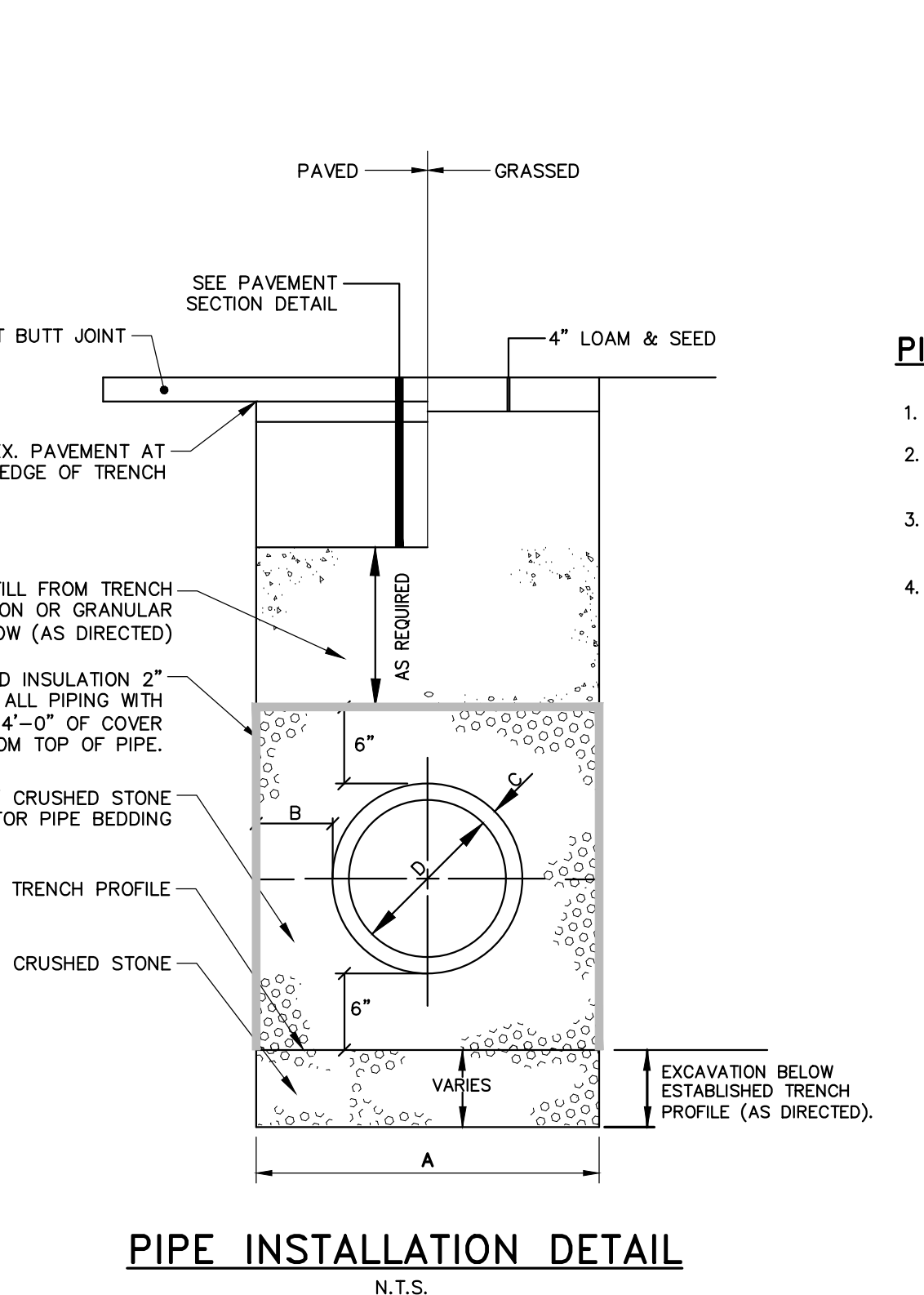
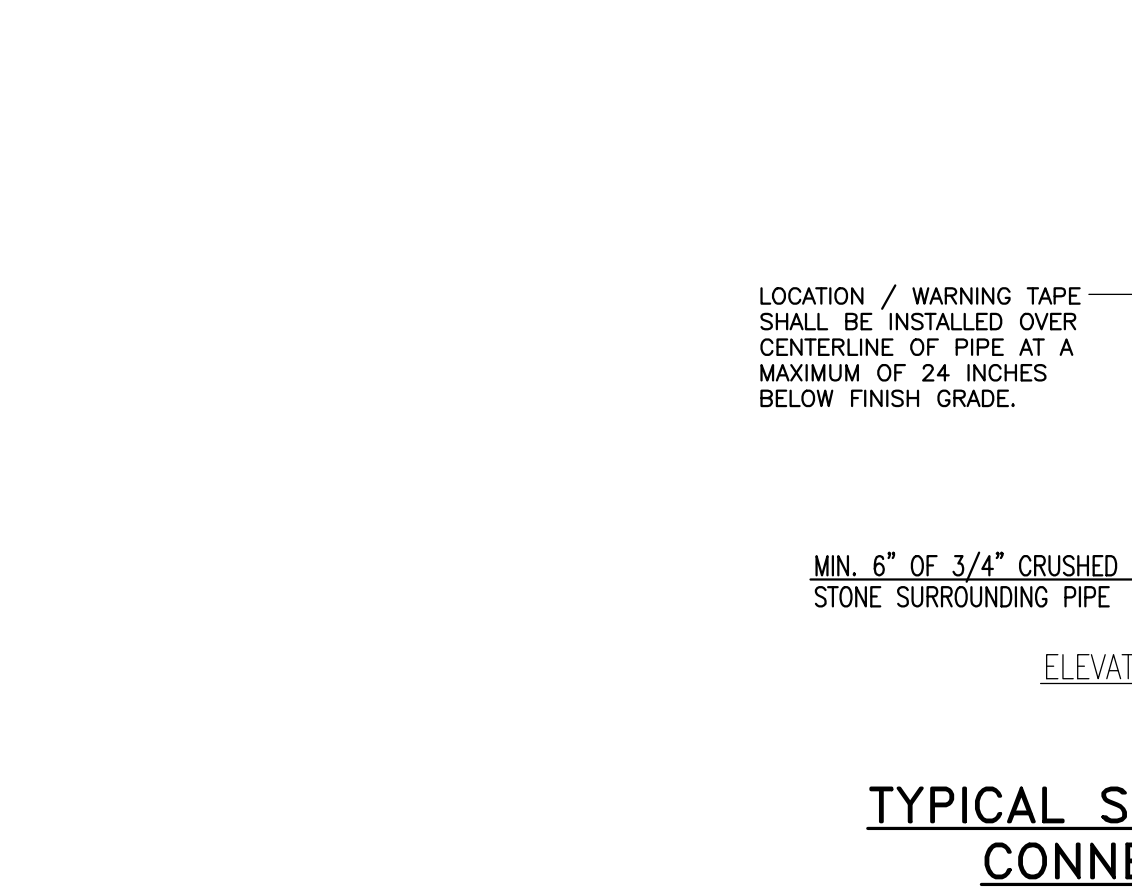
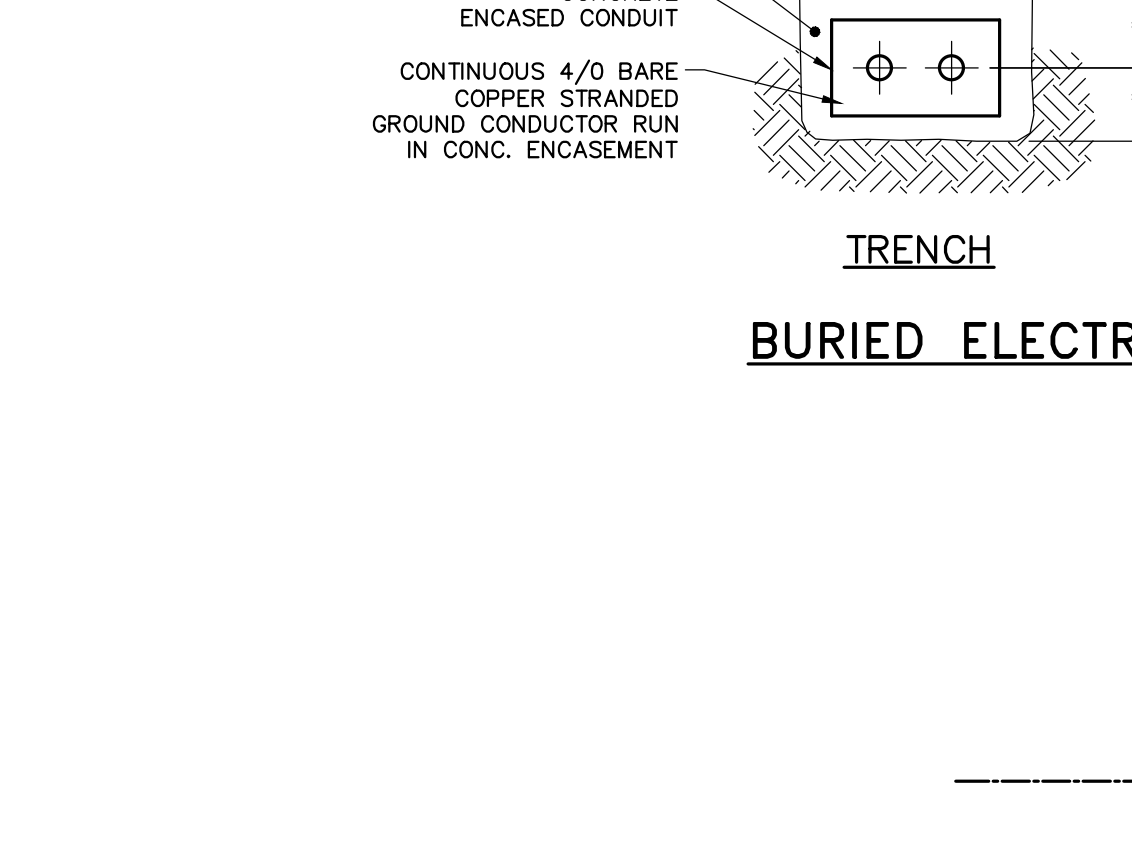
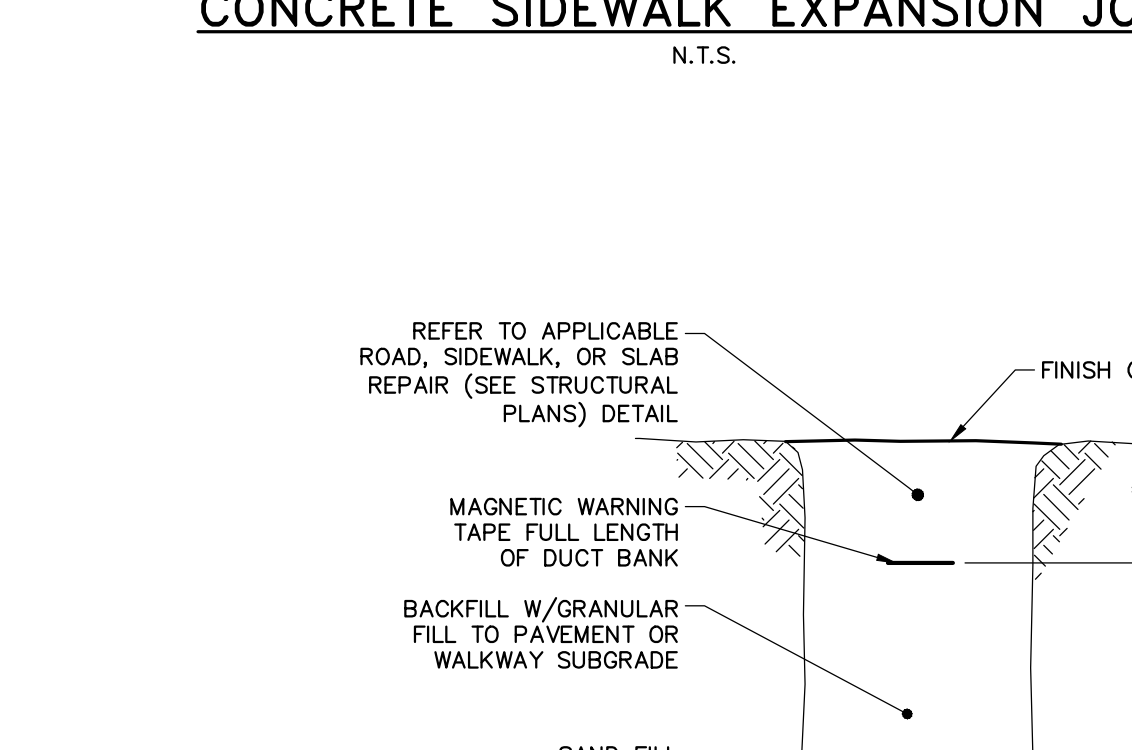
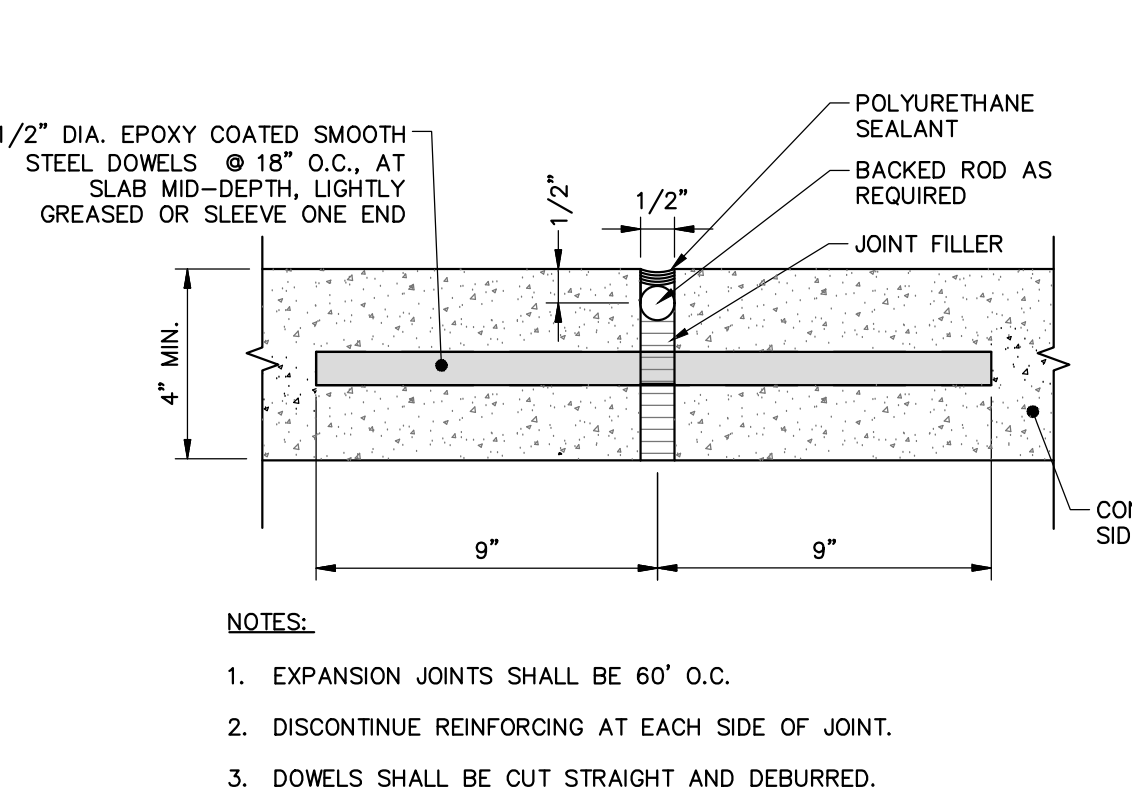
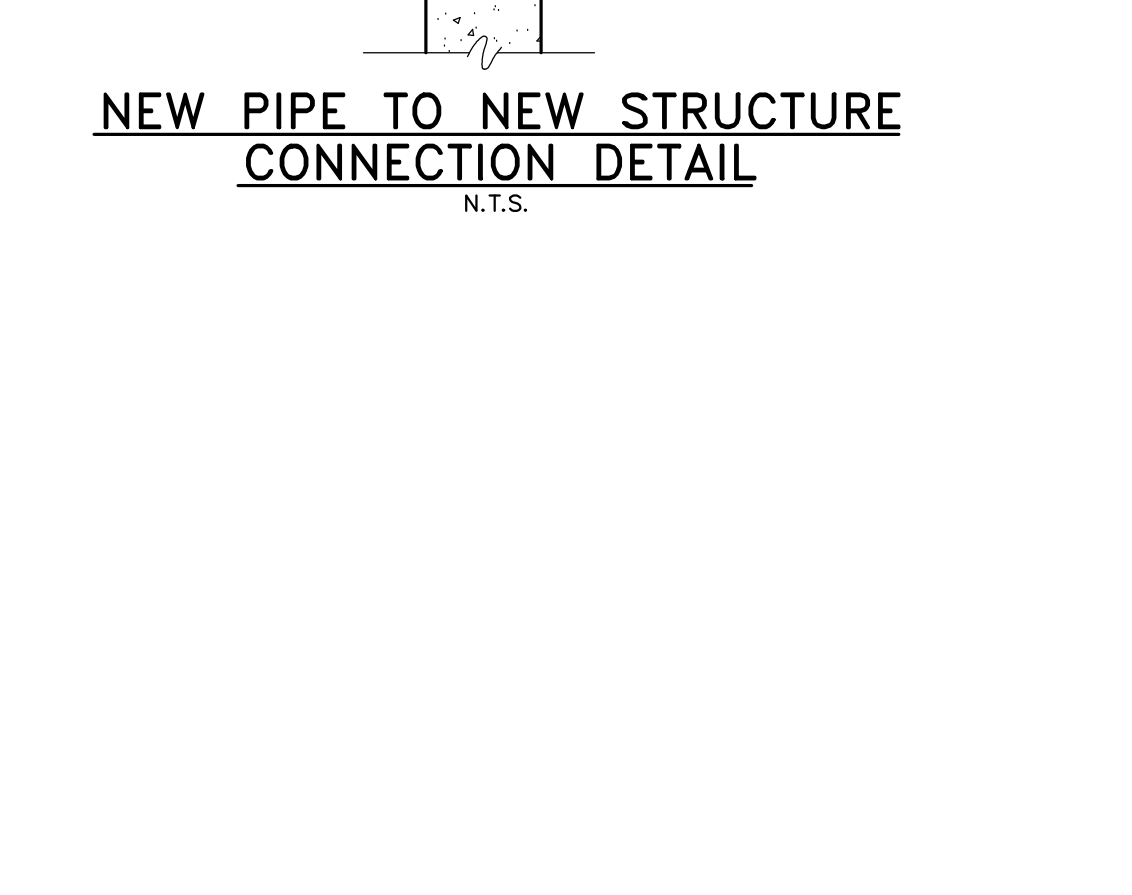
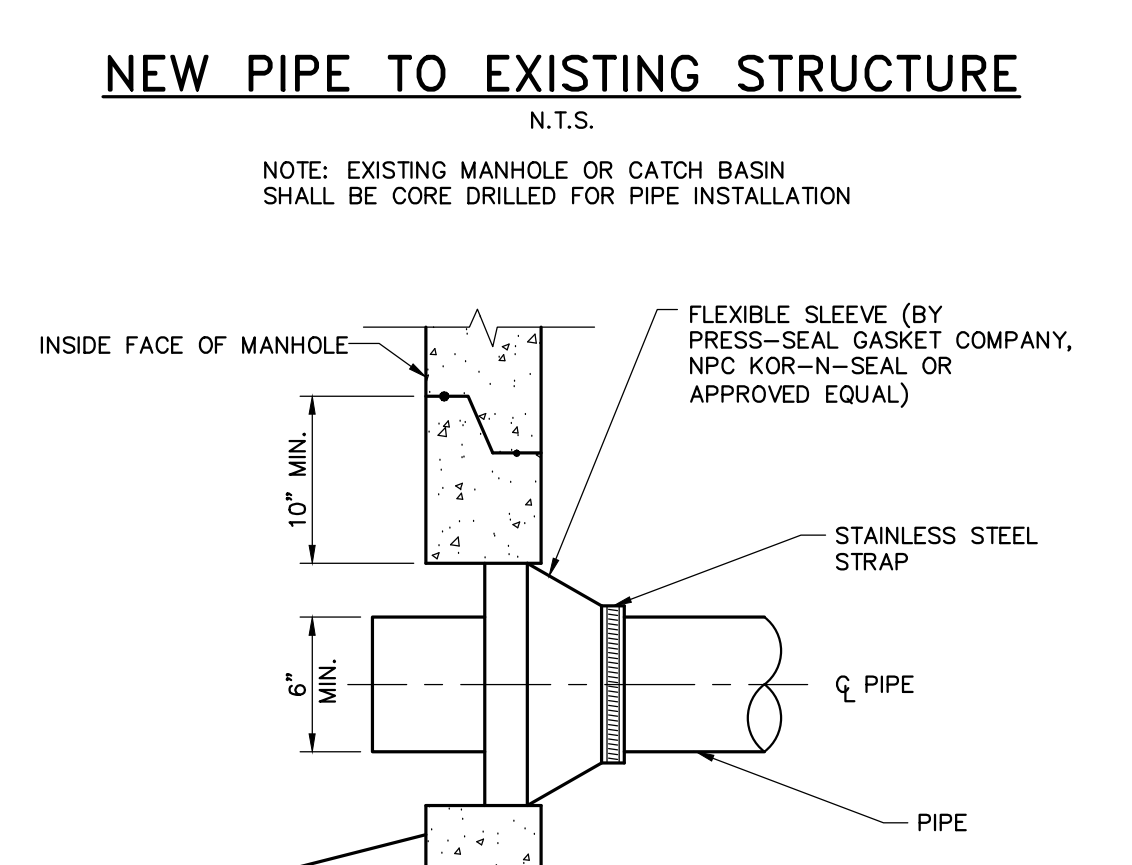
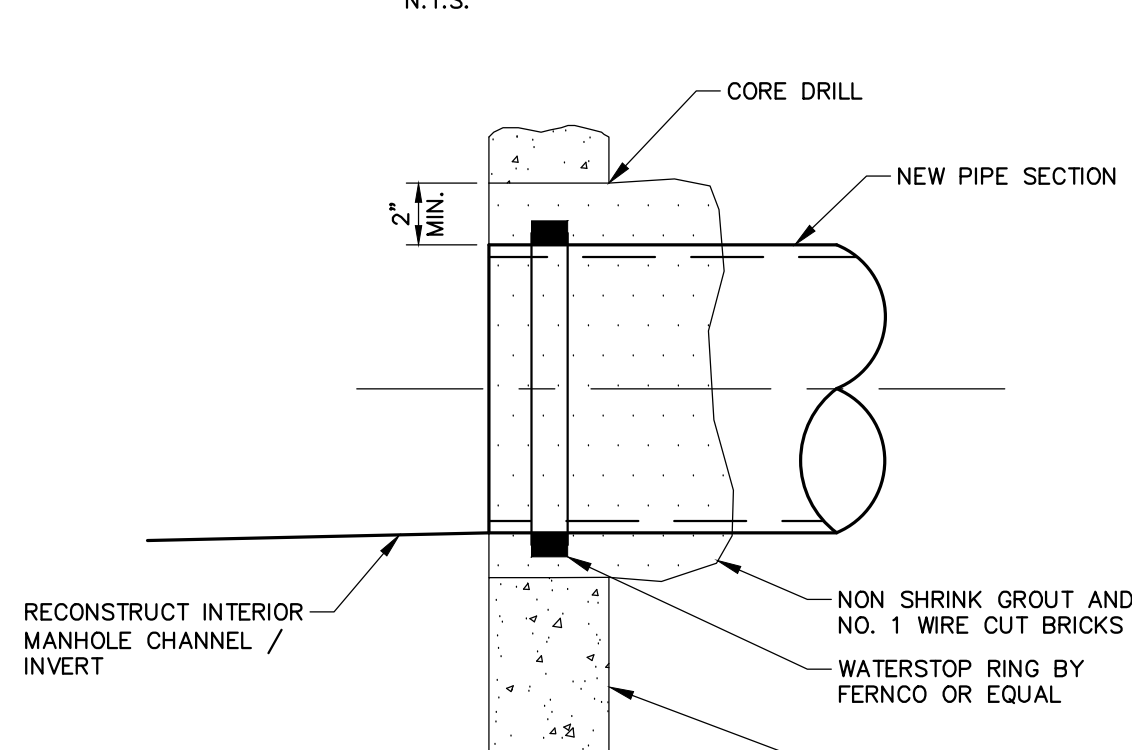
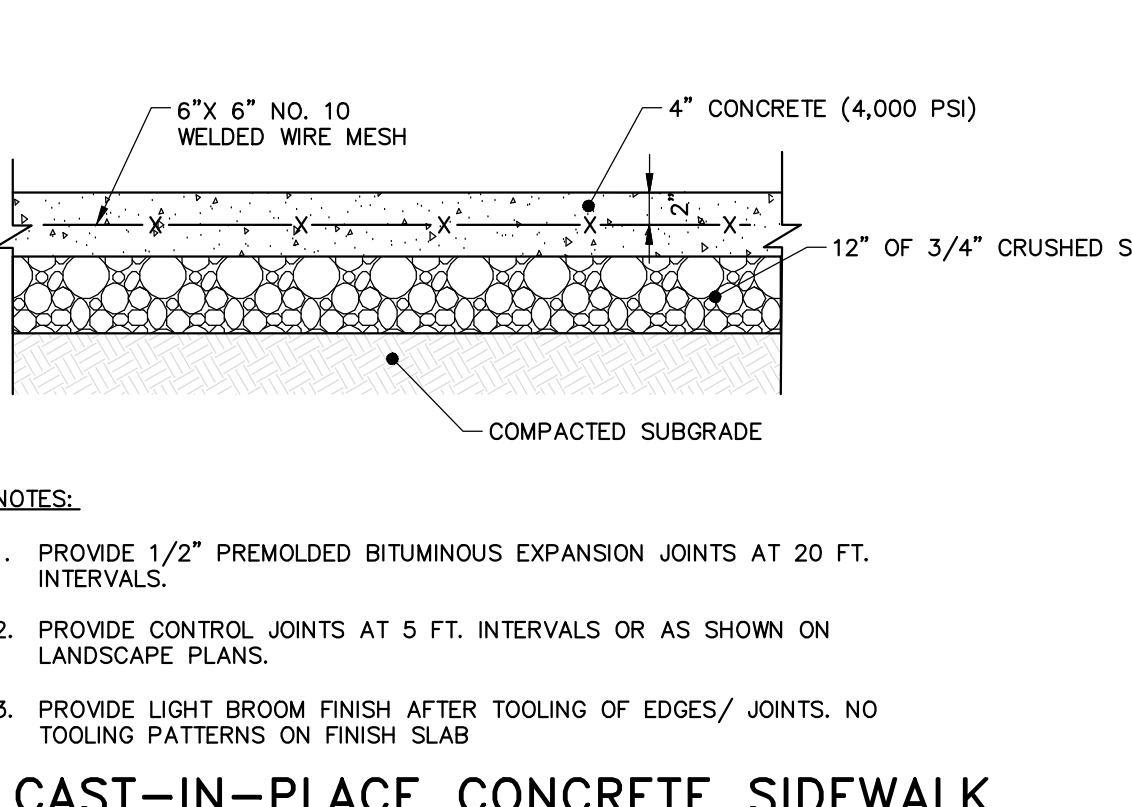
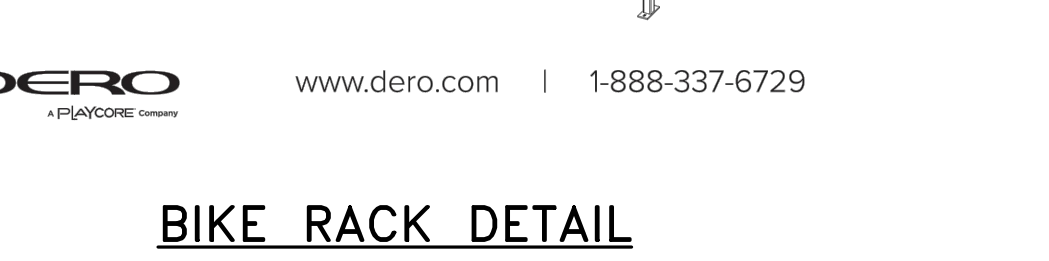
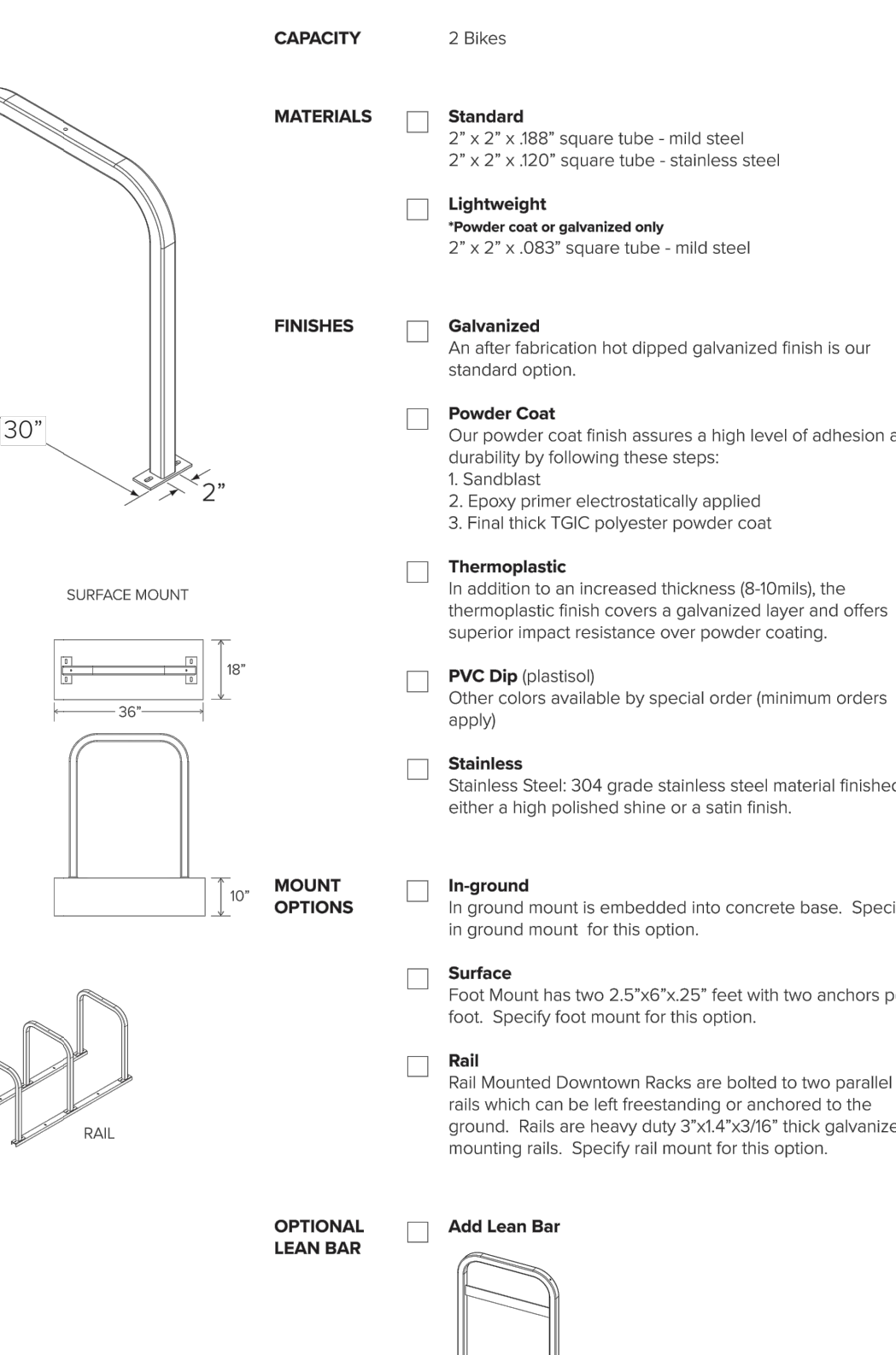
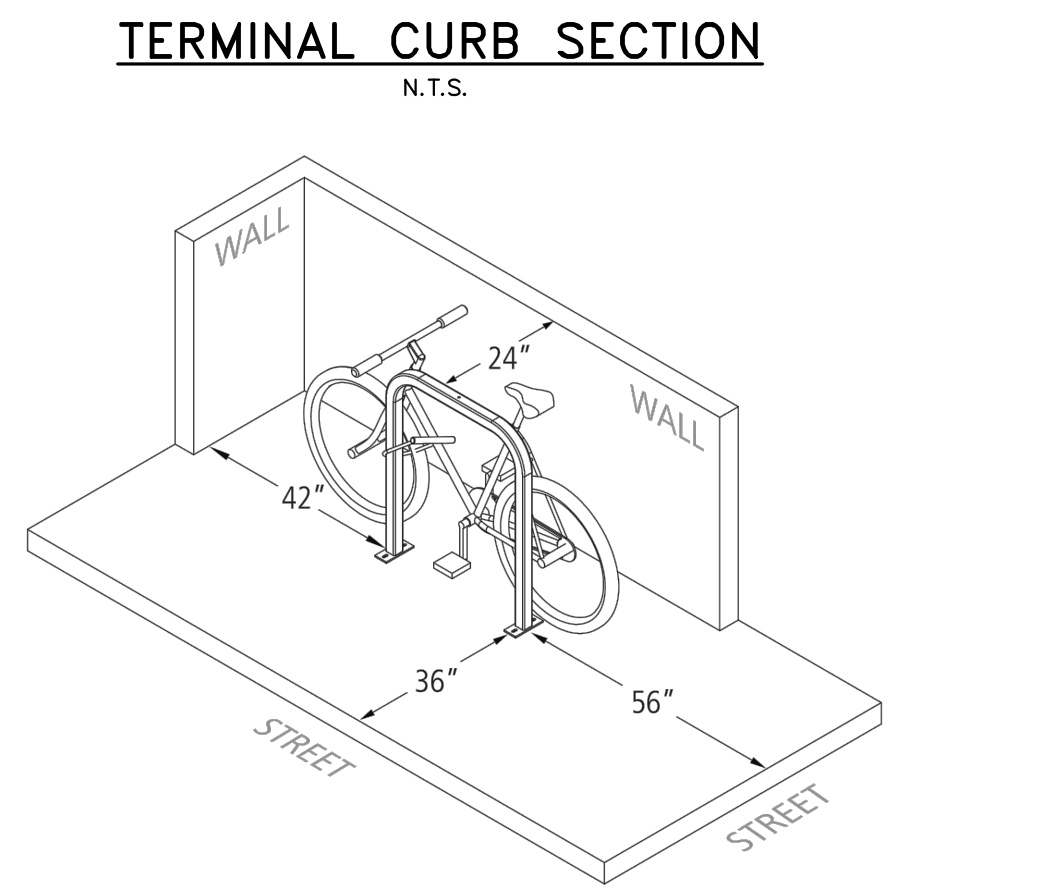
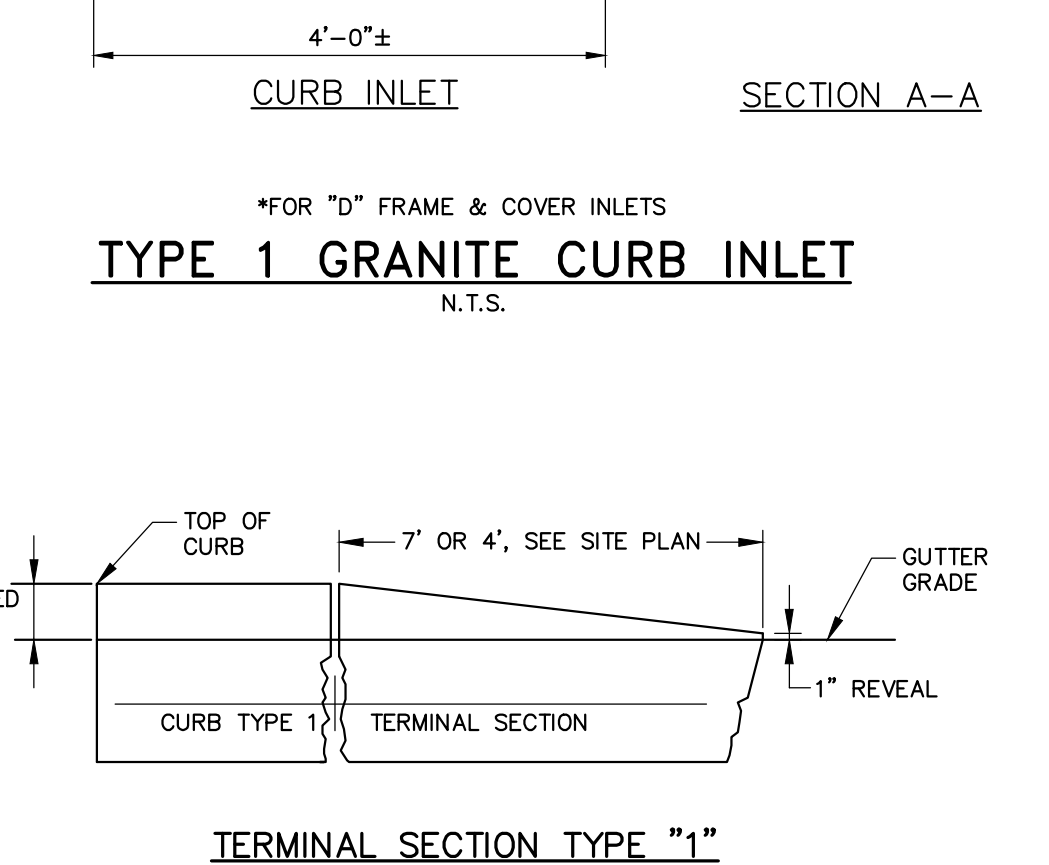
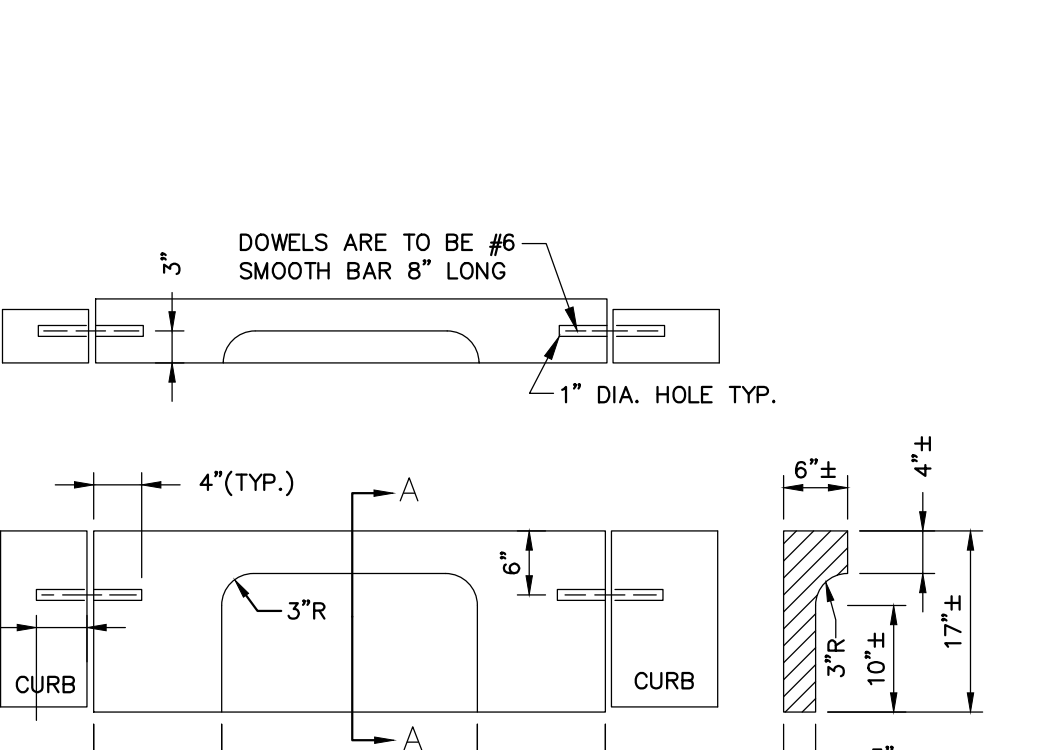
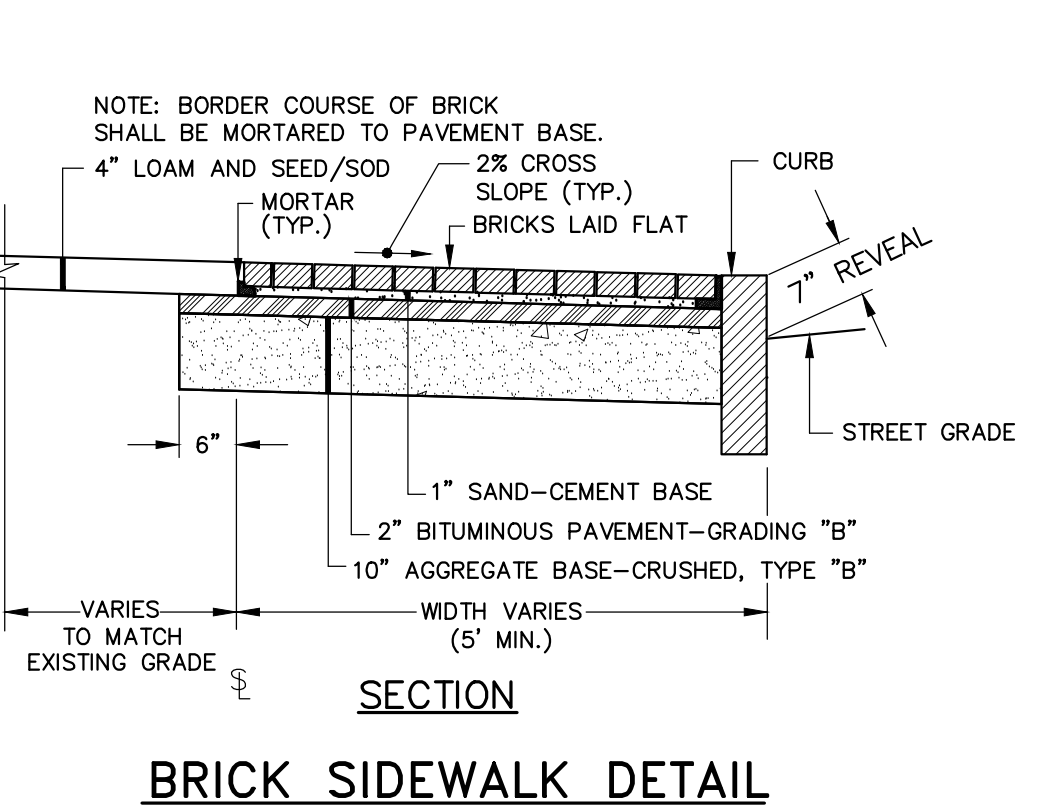

41 Hutchins Drive
Portland, Maine 04102
800.426.4362 | www.woodward-clark.com

WOODWARD-CLARK
CONSULTING ENGINEERS

COMMITMENT & INTEGRITY DRIVE RESULTS

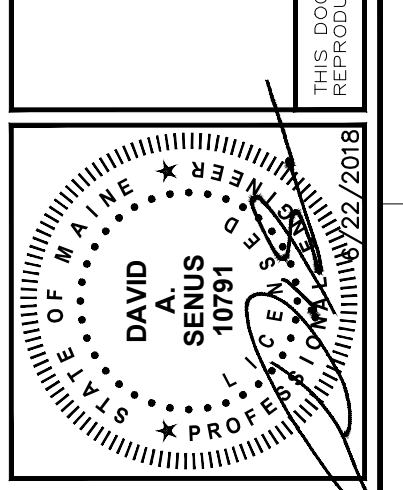

NO.	DATE	DESCRIPTION	BY	CHKD.
1	12/24/2018	RESPONSE TO COMMENTS SUBMISSION		
2	8/23/2018	RESPONSE TO COMMENTS SUBMISSION		

DESIGNED BY: DMS
CHECKED BY: C-203
DATE: 03/19/2019

CIVIL DETAILS - 3

MAINE MEDICAL CENTER
BRANHALL STREET
PORTLAND, ME 04102

MMC ST. JOHN STREET
EMPLOYEE PARKING GARAGE

JOB NO: 0231158-00
DATE: JUNE 22, 2018
SCALE: AS NOTED
SHEET: 14 OF 17

C-202