

EROSION AND SEDIMENT CONTROL NOTES

Temporary Erosion Control

Contractor shall prepare and submit a soil erosion and sediment control plan to engineer in accordance with section 656.

Table with 4 columns: Measure, Dates For Use, Timing, Activity, and Location. Includes rows for Sedimentation Barrier, Up-slope Diversion, Catch Basin Protection, Dust Control, Temporary Seeding, Mulch, Winter Mulch, and Inspections.

Permanent Erosion Control:

Table with 4 columns: Measure, Dates For Use, Timing, Activity, and Location. Includes rows for Pavement - Base Course, Permanent Seeding, Dormant Seeding, Ground Cover, Trees, Shrubs, and Permanent Mulch.

Inspections:

Regular inspections of all erosion and sedimentation controls shall be made at least weekly and prior to and following storm events. Minimum inspections shall be made as listed in the table below.

Table with 2 columns: Inspected Item, Look For. Lists items like Mulched Surfaces, Seeded Surfaces, Sediment Barrier, Perimeter Diversion, Catch Basin Protection, Dewatering Filter, and Construction Entrance.

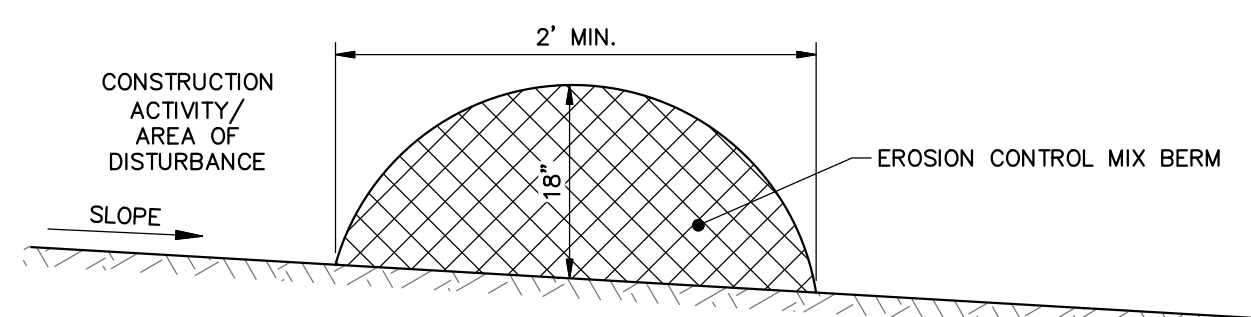

- NOTES: 1. EROSION CONTROL MIX CAN BE MANUFACTURED ON OR OFF THE PROJECT SITE. IT MUST CONSIST PRIMARILY OF ORGANIC MATERIAL... 2. EROSION CONTROL MIX SHALL CONTAIN A WELL-GRADED MIXTURE OF PARTICLE SIZES AND MAY CONTAIN ROCKS LESS THAN 4" IN DIAMETER...

EROSION CONTROL MIX BERM

N.T.S.

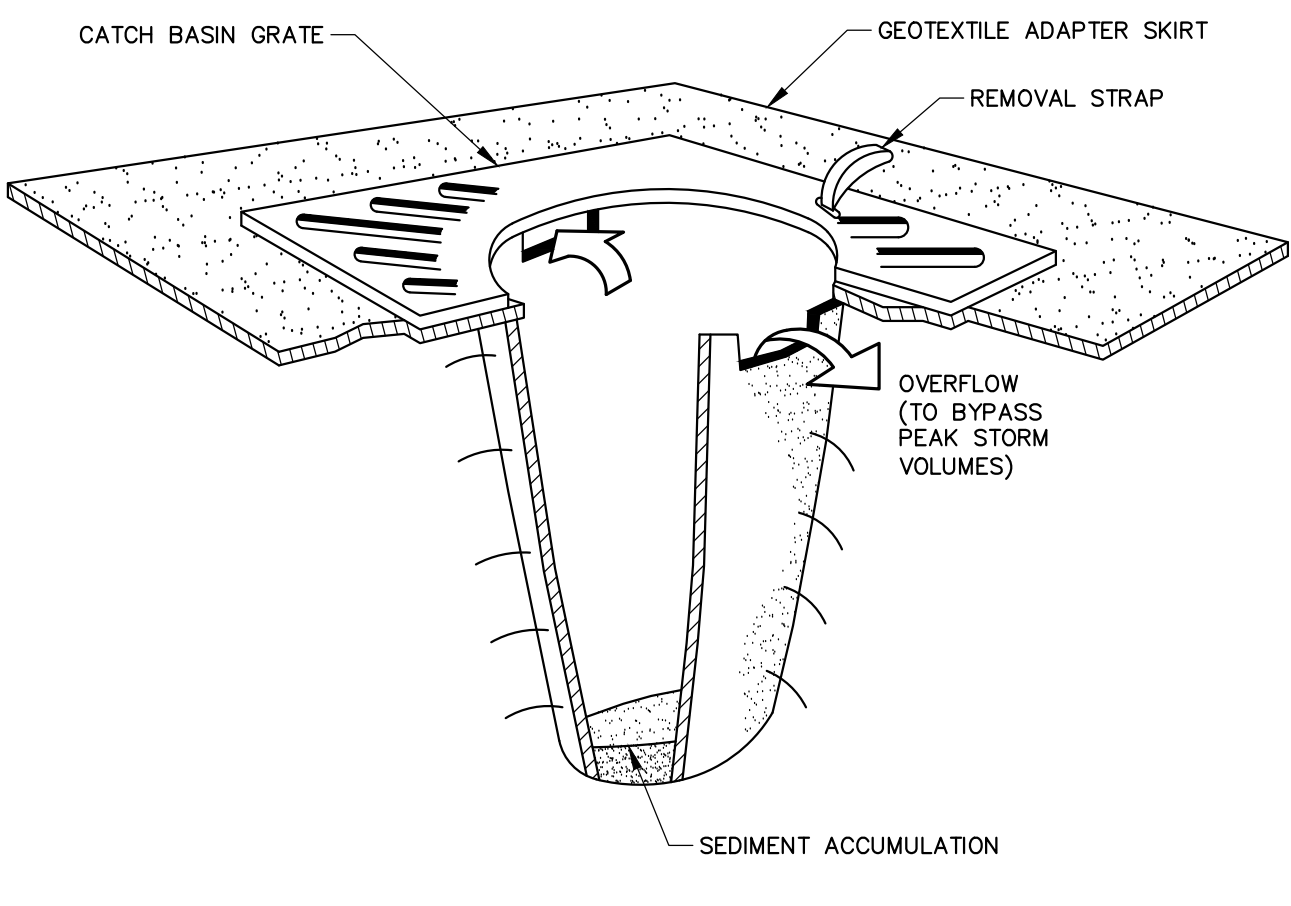
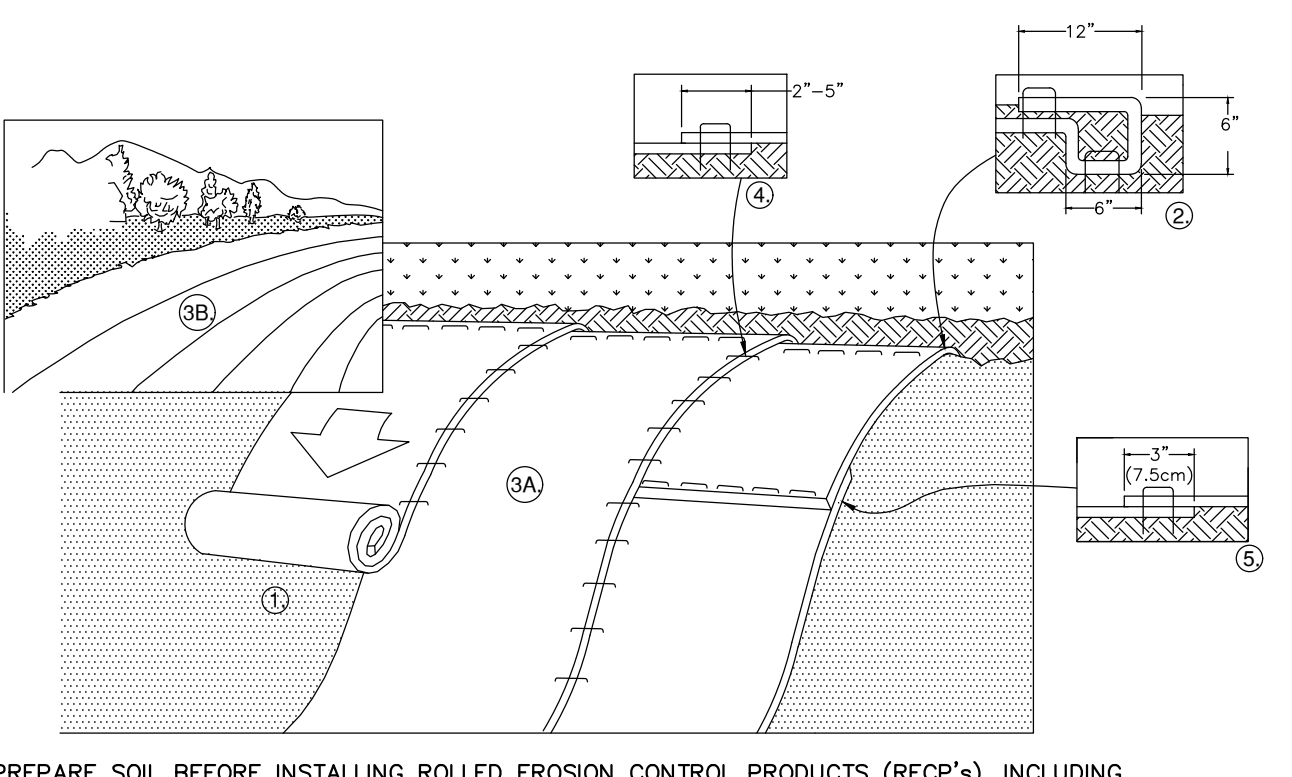

- 1. PREPARE SOIL BEFORE INSTALLING ROLLED EROSION CONTROL PRODUCTS (RECP'S), INCLUDING ANY NECESSARY APPLICATION OF LIME, FERTILIZER, AND SEED AS WELL AS REMOVING ANY PROTRUDING ROCKS, STUMPS OR ROOTS... 2. BEGIN AT THE TOP OF THE SLOPE BY ANCHORING THE RECP'S IN A 6" DEEP X 6" WIDE TRENCH WITH APPROXIMATELY 12" OF RECP'S EXTENDED BEYOND THE UP-SLOPE PORTION OF THE TRENCH...

NOTES: CATCH BASIN PROTECTION TO BE "SILT-SACK" (BY ACF ENVIRONMENTAL) OR "STREAM GUARD" (BY FOSS ENVIRONMENTAL SERVICES)...

TEMPORARY INLET PROTECTION

N.T.S.

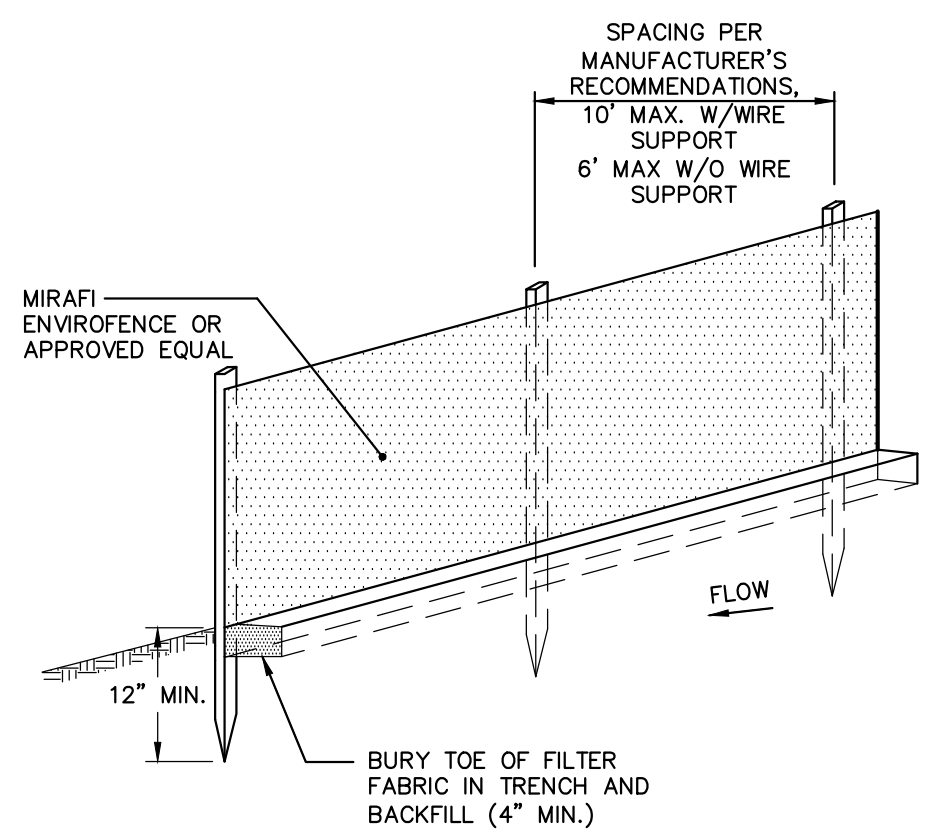

- NOTES: • INSTALL FABRIC ON UPHILL SIDE OF SUPPORT POSTS • INSTALL SILT FENCE ACROSS SLOPES • SILT FENCE SHALL NOT BE USED IN DRAINAGEWAYS

MAINTENANCE: INSPECT FOR TEARS IN THE FABRIC OR DAMAGE TO SUPPORTS. REPAIR AS NECESSARY. REMOVE ACCUMULATED SEDIMENT WHEN IT REACHES A DEPTH OF SIX-INCHES OR LESS.

REMOVAL: WHEN UPSLOPE AREAS ARE STABILIZED, THE STRUCTURE AND ANY ACCUMULATED SEDIMENT WILL BE REMOVED.

SEDIMENT BARRIER - SILTATION FENCE DETAIL

N.T.S.

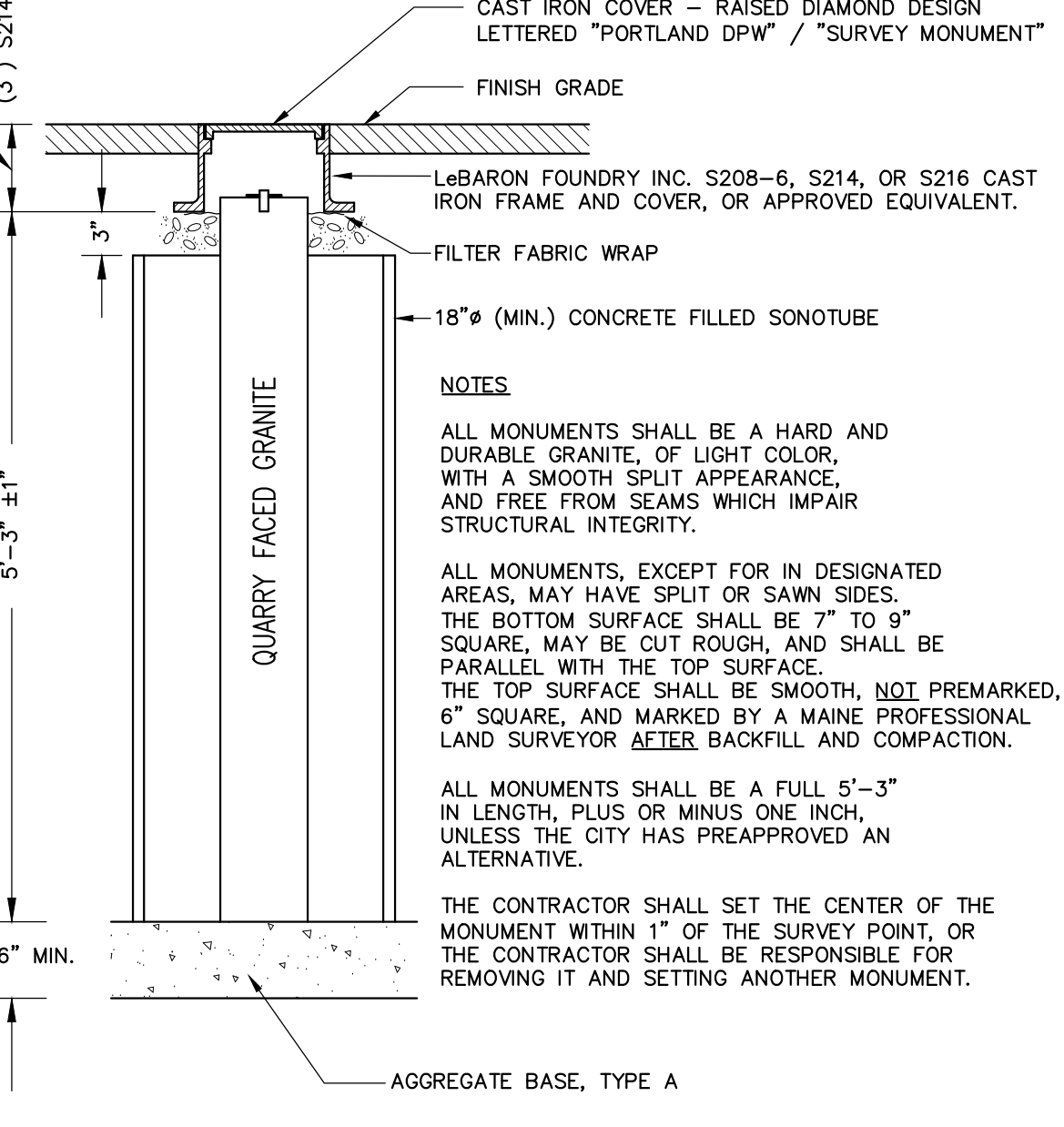
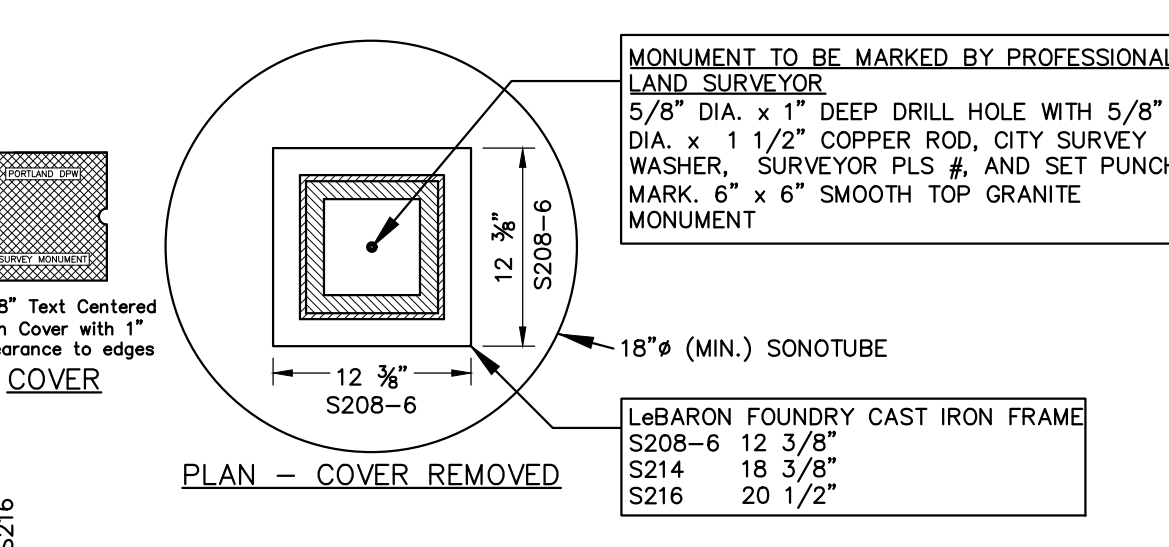

GRANITE STREET MONUMENT

N.T.S.

NOTE: AGGREGATE TYPES PER MDT SECTION 304.02

ROLLED EROSION CONTROL MATTING

N.T.S.

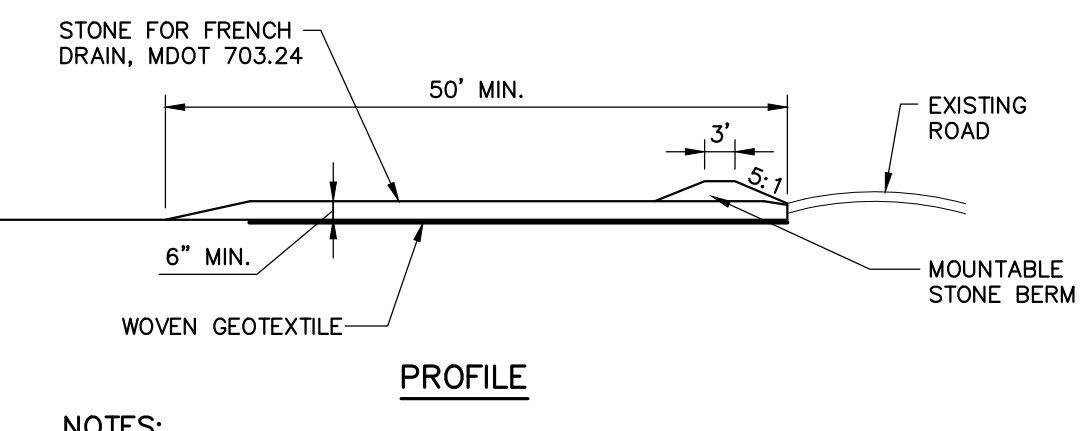
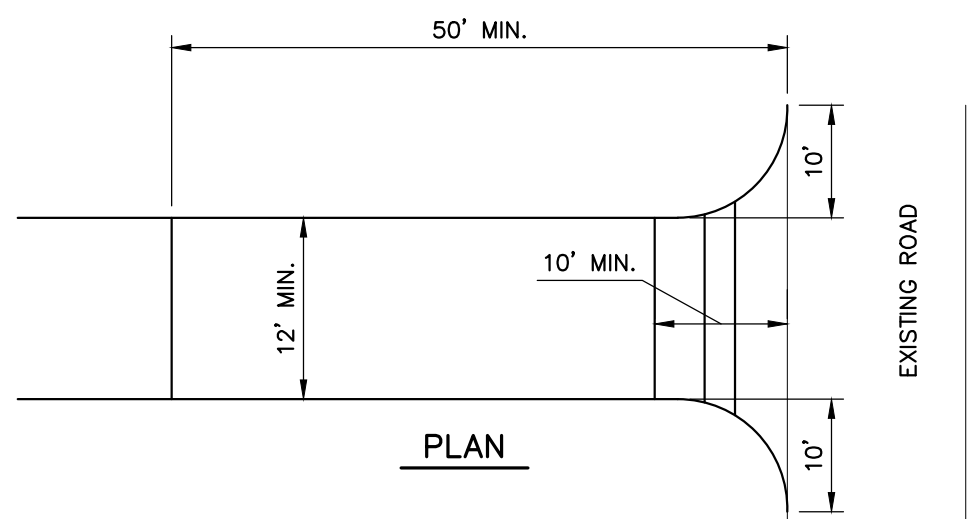

- NOTES: • CONSTRUCTION ENTRANCES MAY BE RELOCATED AS CONSTRUCTION PROGRESSES. • WHEEL WASH PITS MAY ALSO BE USED, IF APPROVED.

MAINTENANCE: INSPECT FOR EFFECTIVE REMOVAL OF SOIL FROM VEHICLES PRIOR TO LEAVING THE SITE. SWEEP ANY SOIL FROM ADJACENT ROADWAYS.

REMOVAL: AT LEAST ONE CONSTRUCTION ENTRANCE SHALL BE MAINTAINED UNTIL ALL AREAS OF THE SITE ARE STABILIZED.

STABILIZED CONSTRUCTION ENTRANCE DETAIL

N.T.S.

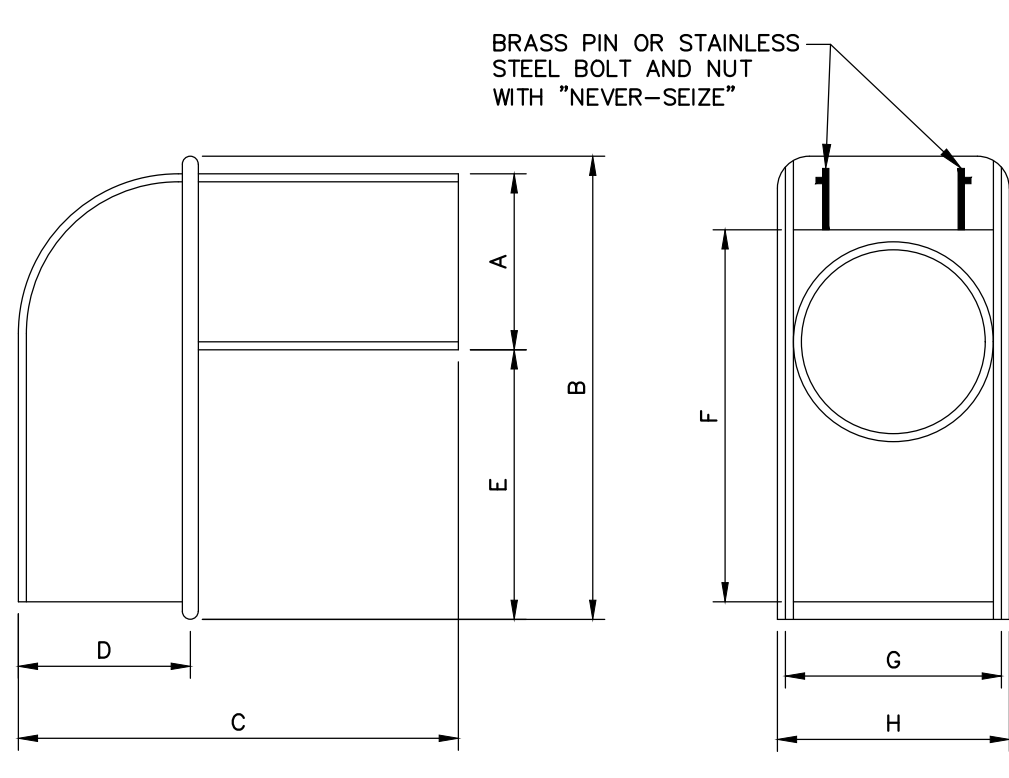

Table with 9 columns: SIZE, A, B, C, D, E, F, G, H. Lists dimensions for 10 inch and 15 inch casco traps.

- 1. CASCO TRAP SHALL BE CAST IRON CASCO TRAP BY ETHERIDGE FOUNDRY OR APPROVED EQUAL. 2. BOLT AND NUT REQUIRED WHERE HOOD WILL NOT OPEN COMPLETELY. 3. CASCO TRAP SHALL BE INSTALLED ON ALL CATCH BASIN OUTLET PIPES, INCIDENTAL TO COST OF CATCH BASIN

CASCO TRAP DETAIL

N.T.S.

Professional seal and contact information for David A. Seneff, P.E., License No. 10401, State of Maine.

Professional seal and contact information for David A. Seneff, P.E., License No. 10401, State of Maine.

Table with columns for REVISIONS, including fields for NO., DESCRIPTION, DATE, and CHECKED BY.

CIVIL DETAILS - 1

MAINE MEDICAL CENTER BRANFILL STREET PORTLAND, ME 04102

MMC ST. JOHN STREET EMPLOYEE PARKING GARAGE

JOB NO: 0231156-00 DATE: JUNE 22, 2018 SCALE: AS NOTED SHEET: 12 OF 17