



BECKER
structural engineers, inc.

75 York Street Portland, ME 04101-4701
info@beckerstructural.com

Tel 207-879-1838 Fax 207-879-1822
www.beckerstructural.com

Consultant

MECHANICAL / ELECTRICAL ENGINEERS

92 Montvale Ave, Suite 4100
Saco, ME 04158
Tel: 781-481-0210 Fax: 781-481-0203
email: info@f-t.com www:f-t.com

FITZMEYER & TOCCI
ASSOCIATES, INC.

Project No.: 09018.00

Consultant

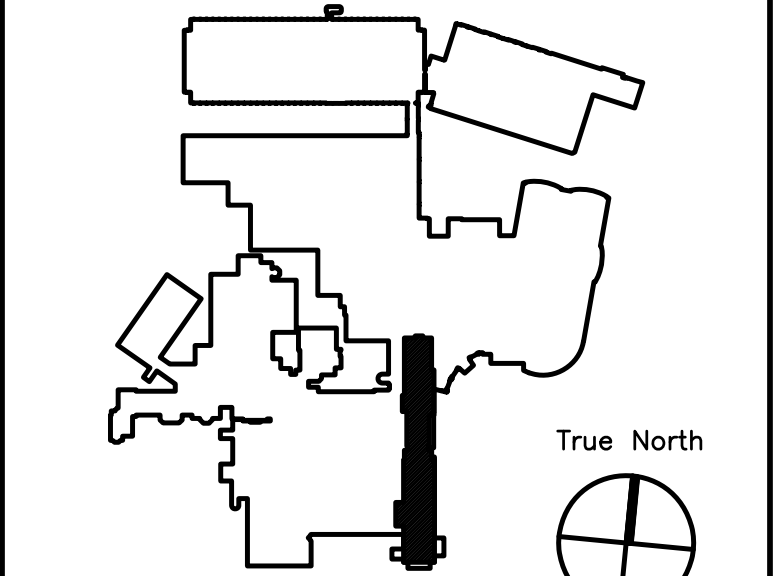

Key Plan N.T.S.

ADDENDUM#1 12/4/09 1

Revision Date No

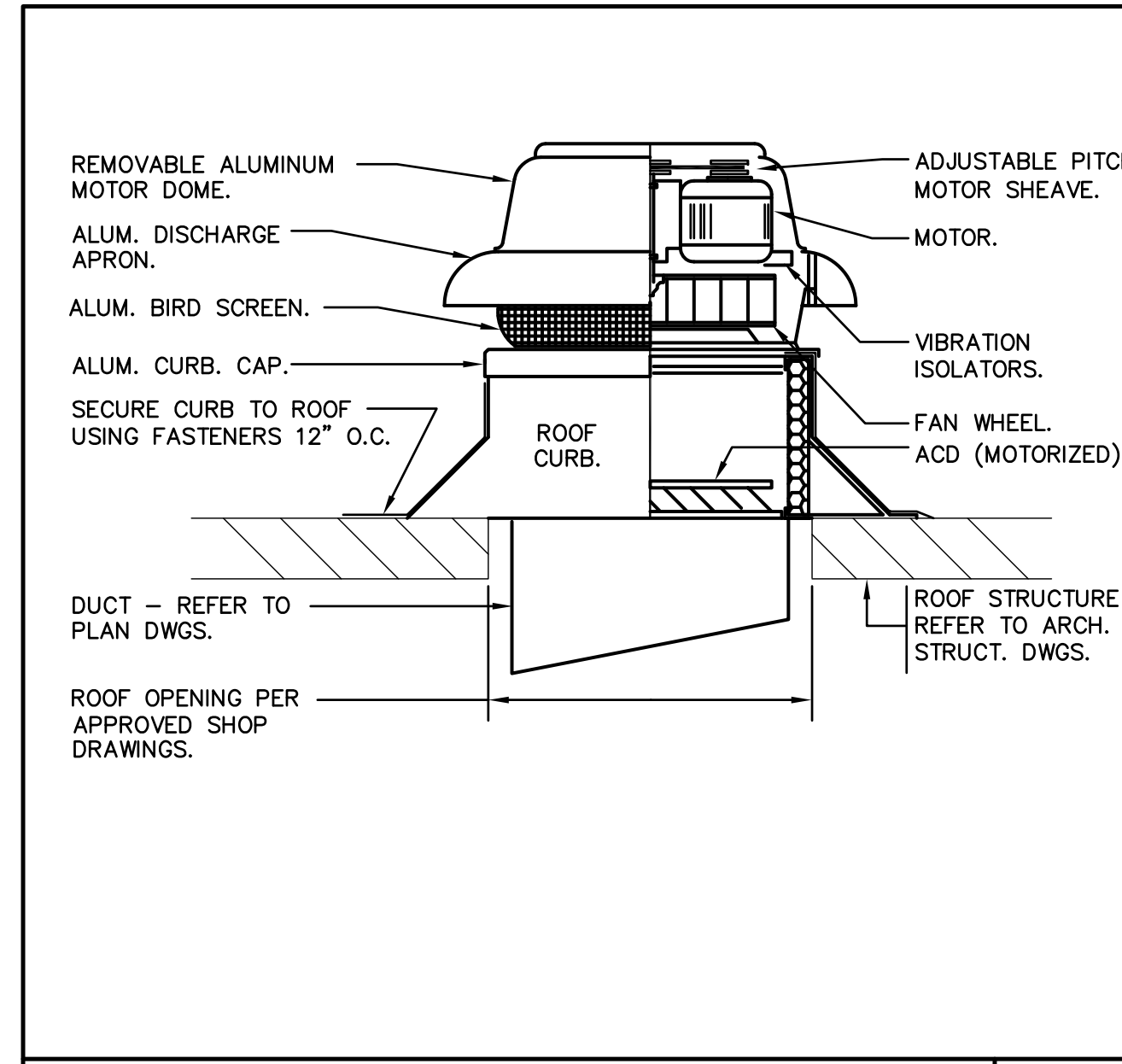

ROOF FAN DETAIL

NO SCALE
15670-03

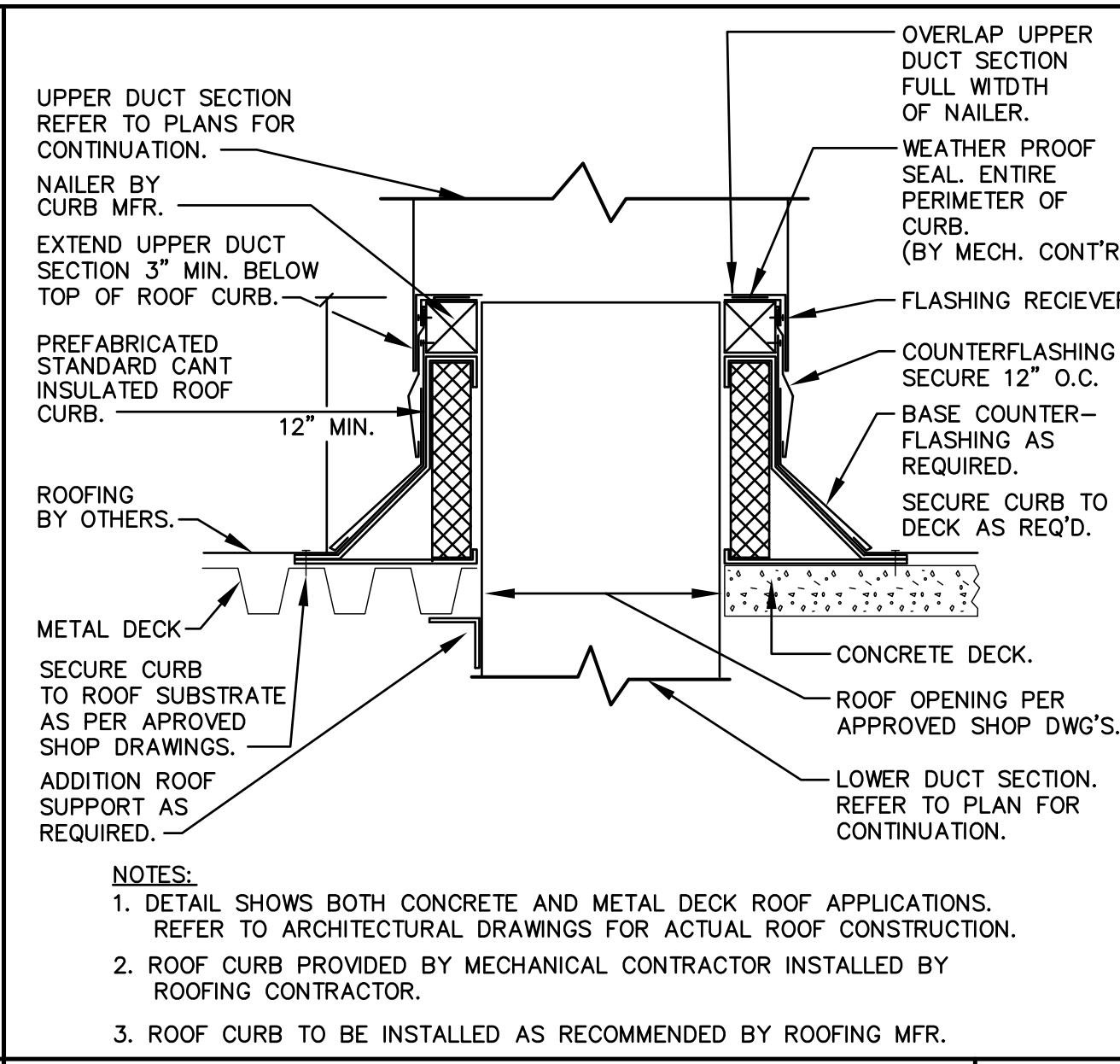

DUCT ROOF PENETRATION

NO SCALE
15617-10

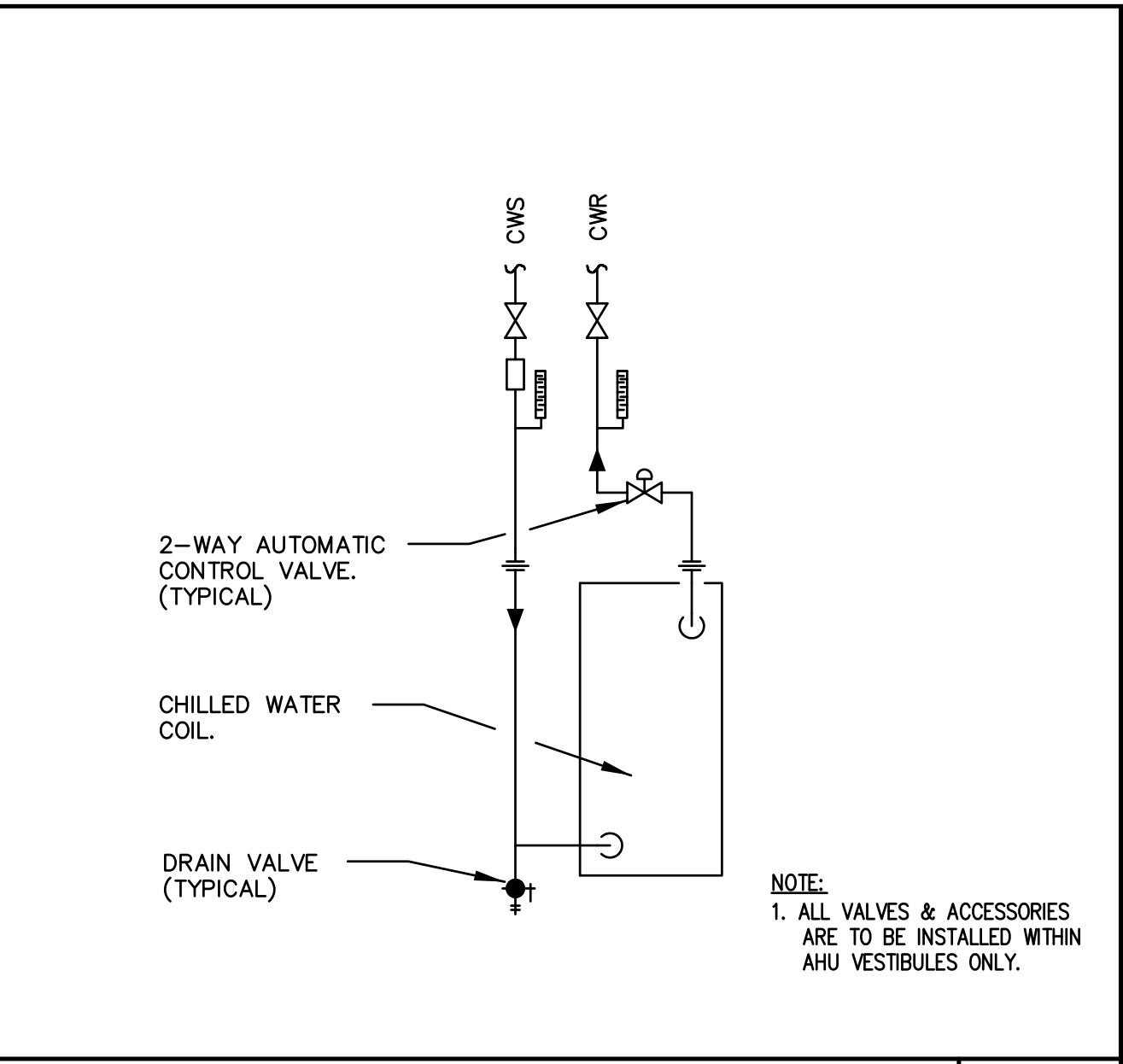

AIR HANDLER CHILLER WATER COIL PIPING

NO SCALE
15644-01

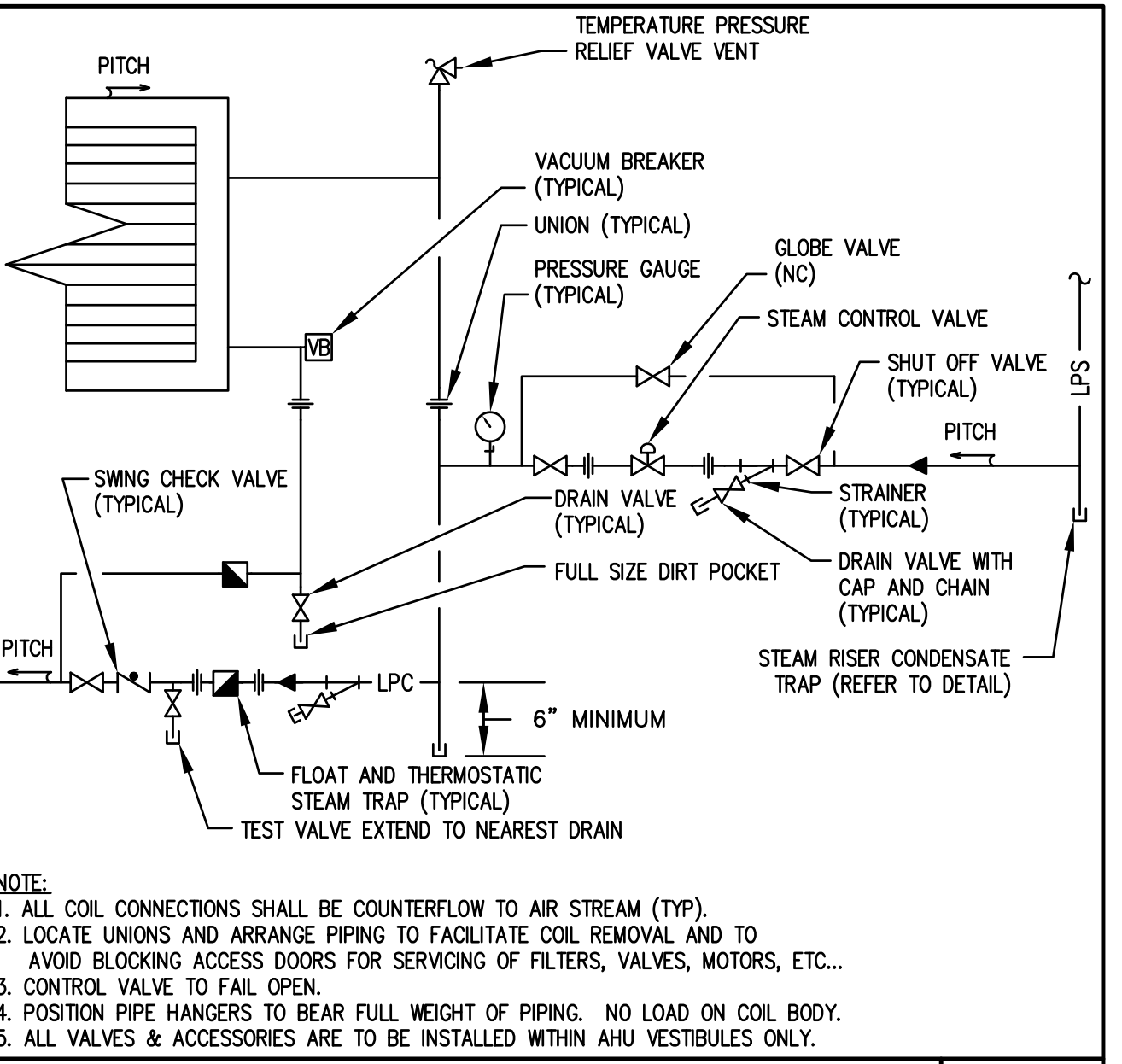

AIR HANDLER STEAM COIL PIPING

NO SCALE
15629-06

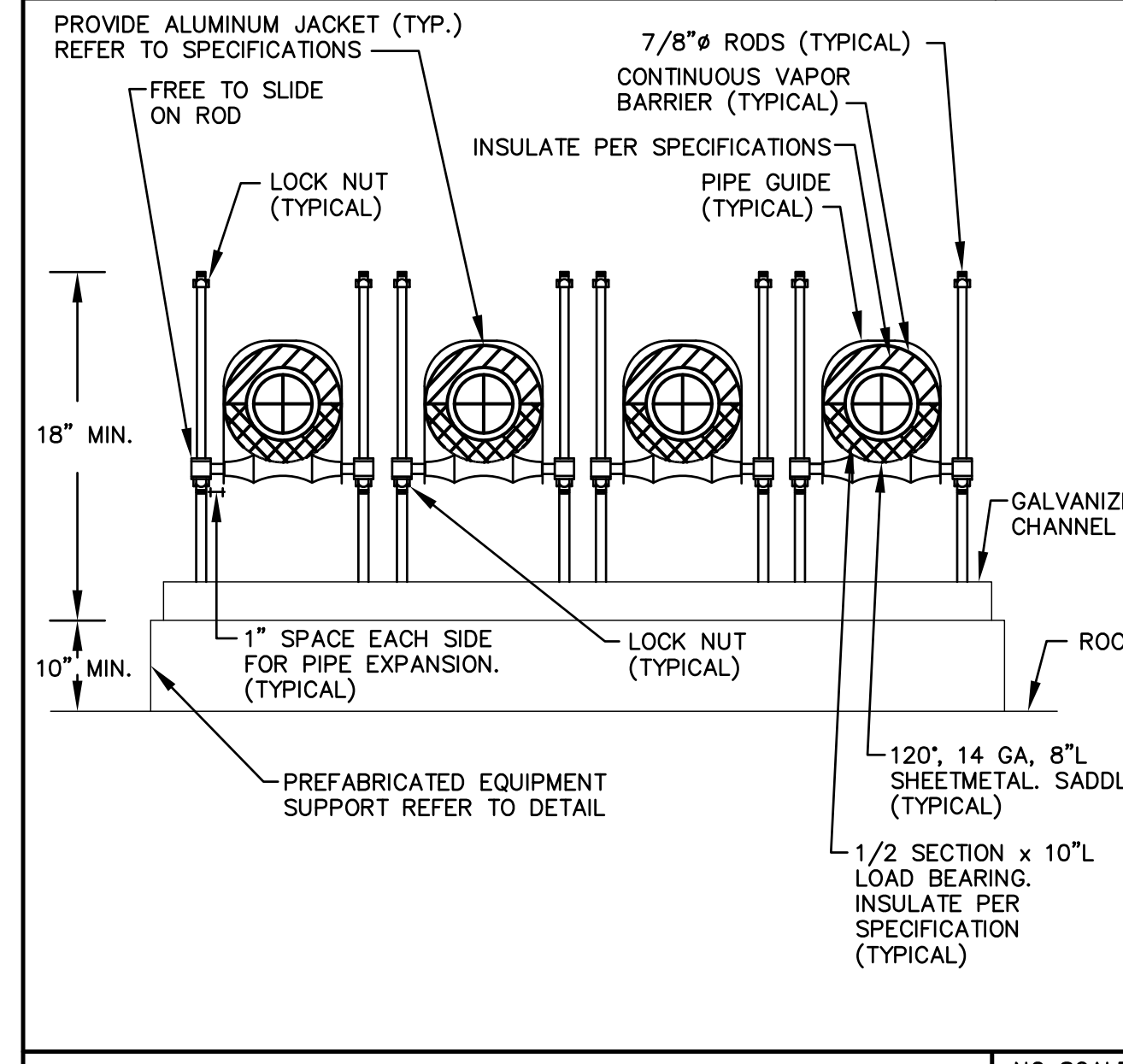

ROOFTOP PIPING SUPPORT DETAIL

NO SCALE
15617-12

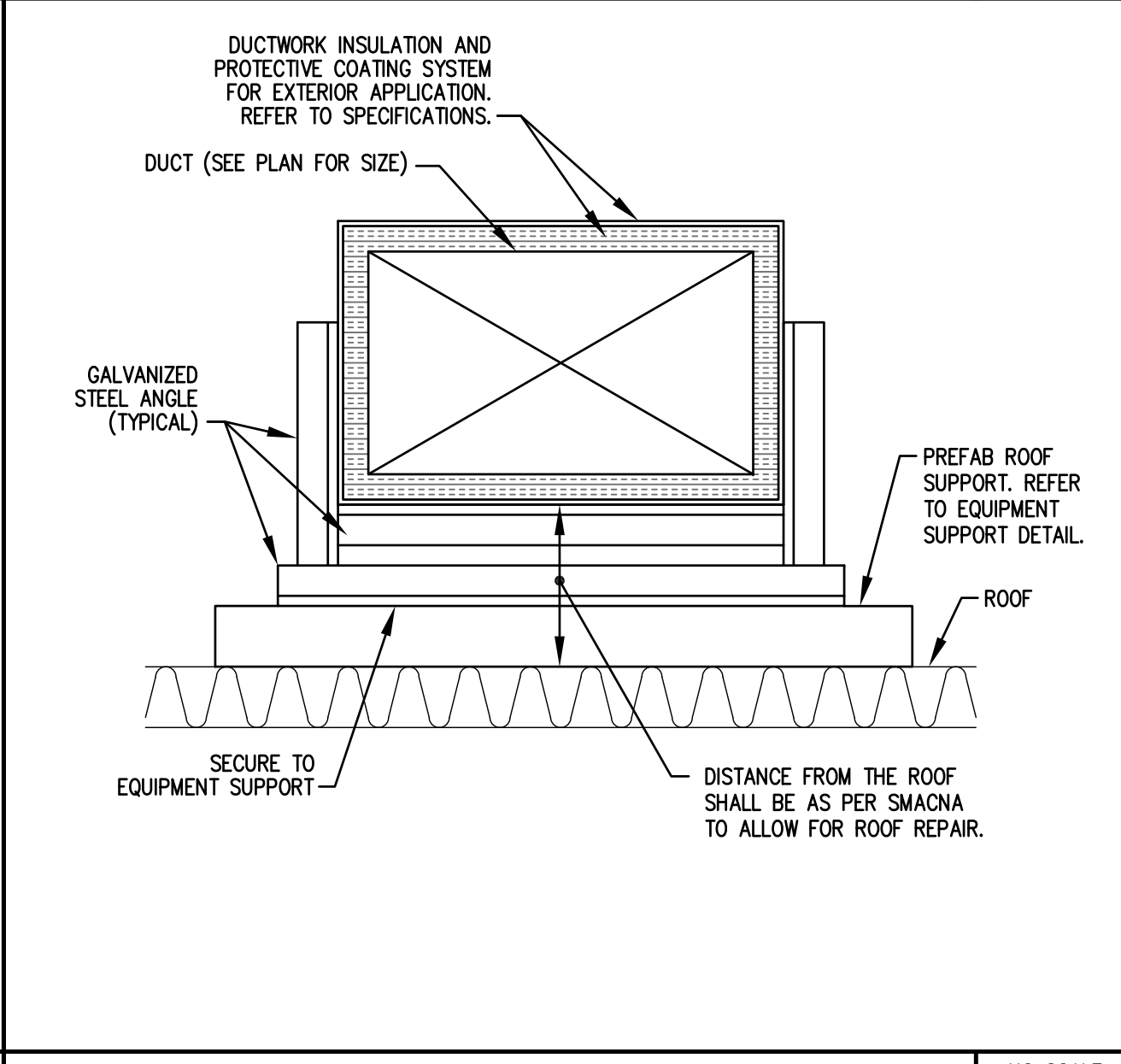

ROOF DUCT SUPPORT DETAIL

NO SCALE
15616-01

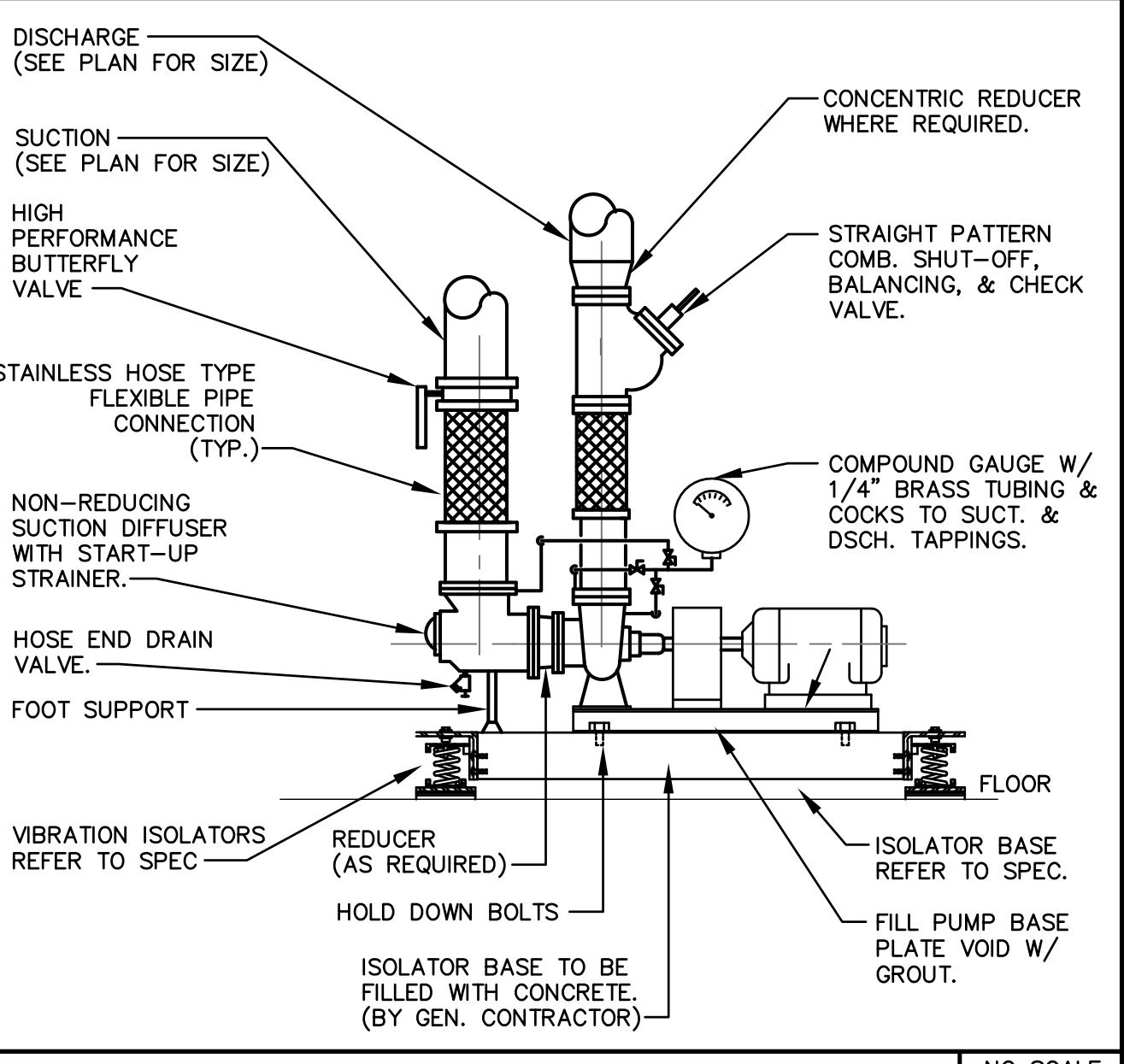

END SUCTION PUMP DETAIL

NO SCALE
15638-01

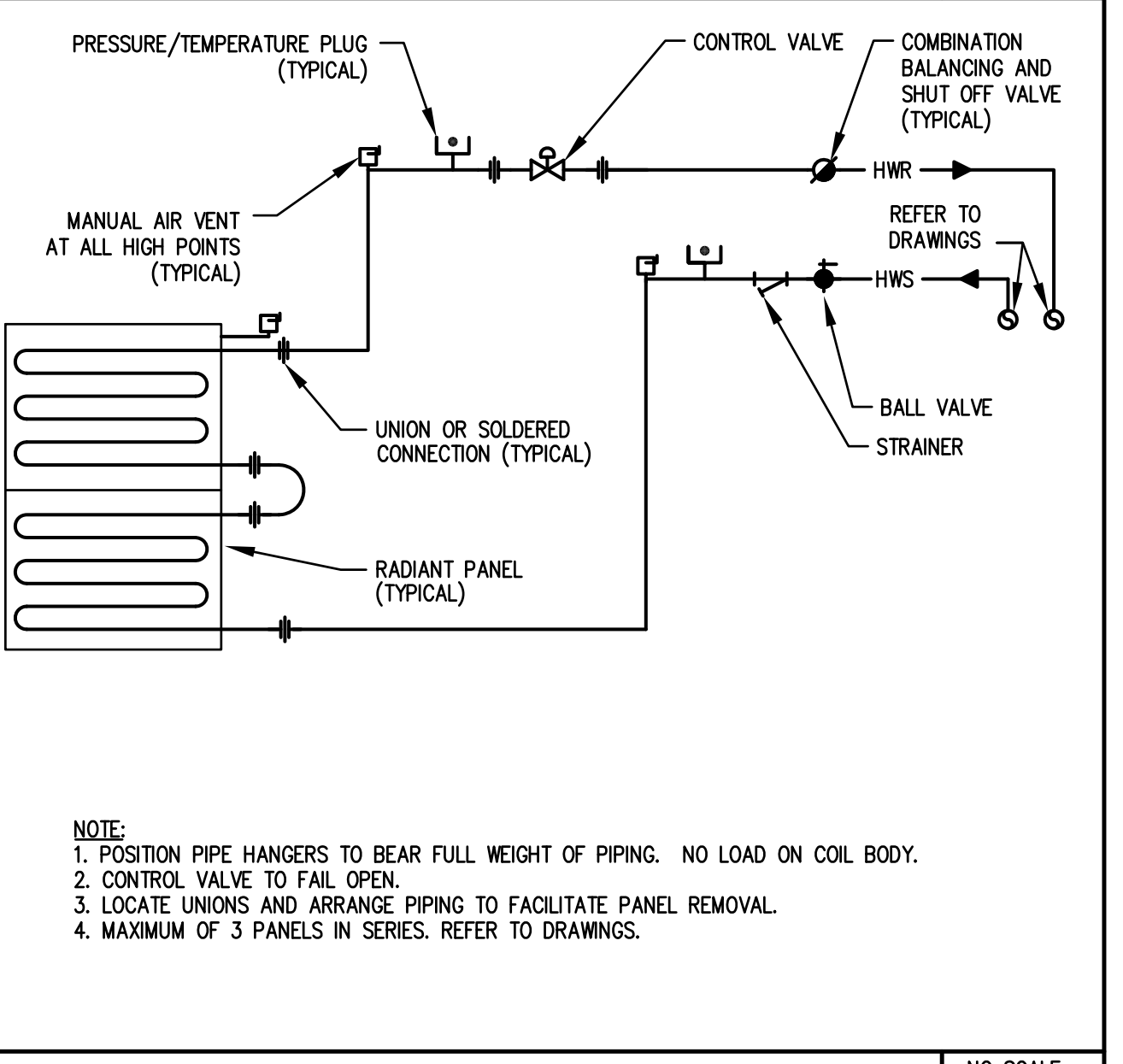

RADIANT PANEL HOT WATER PIPING SCHEMATIC

NO SCALE
15624-03

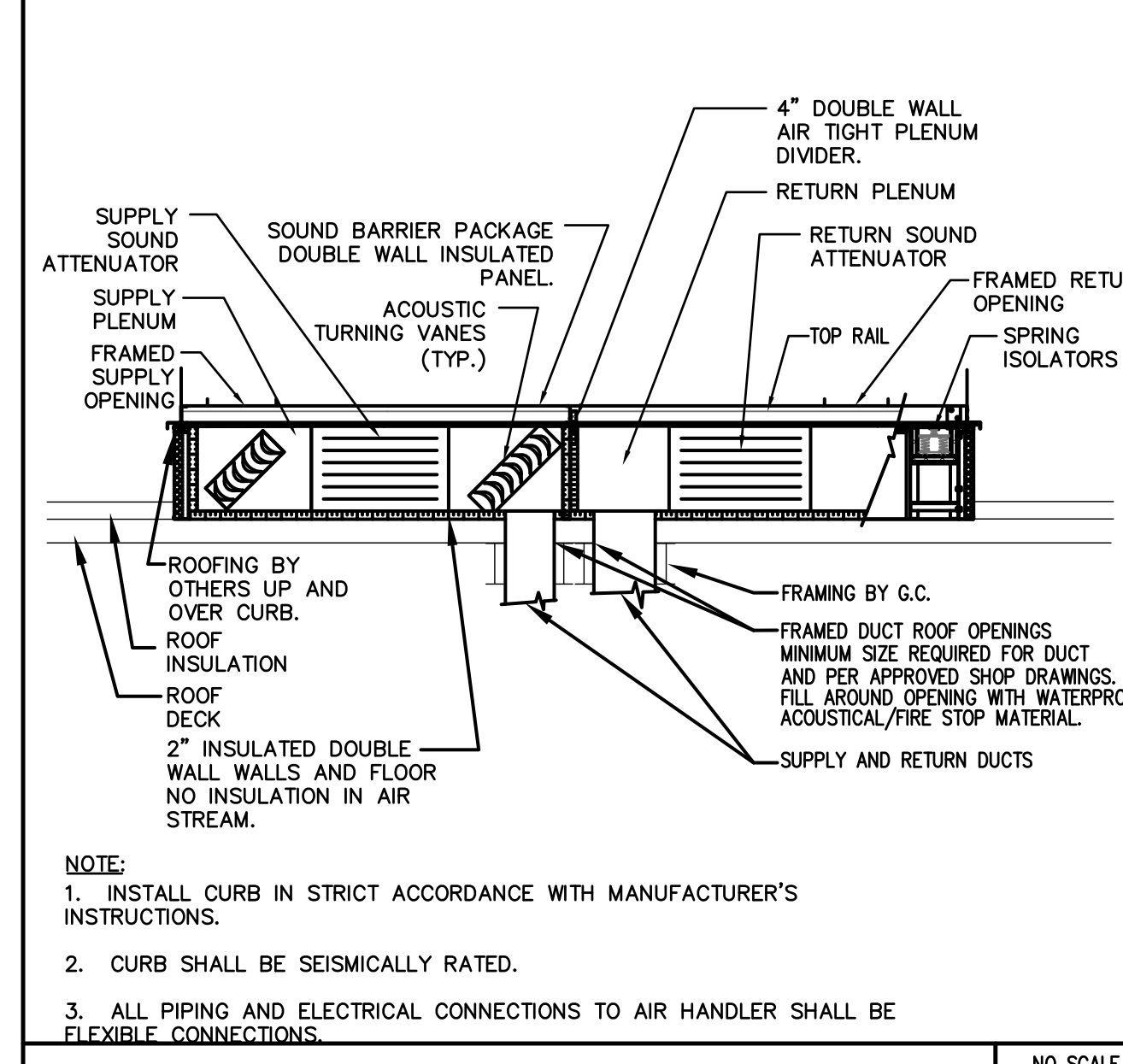

AIR HANDLER SPRING ACOUSTICAL CURB DETAIL - SECTION

NO SCALE
15676-08

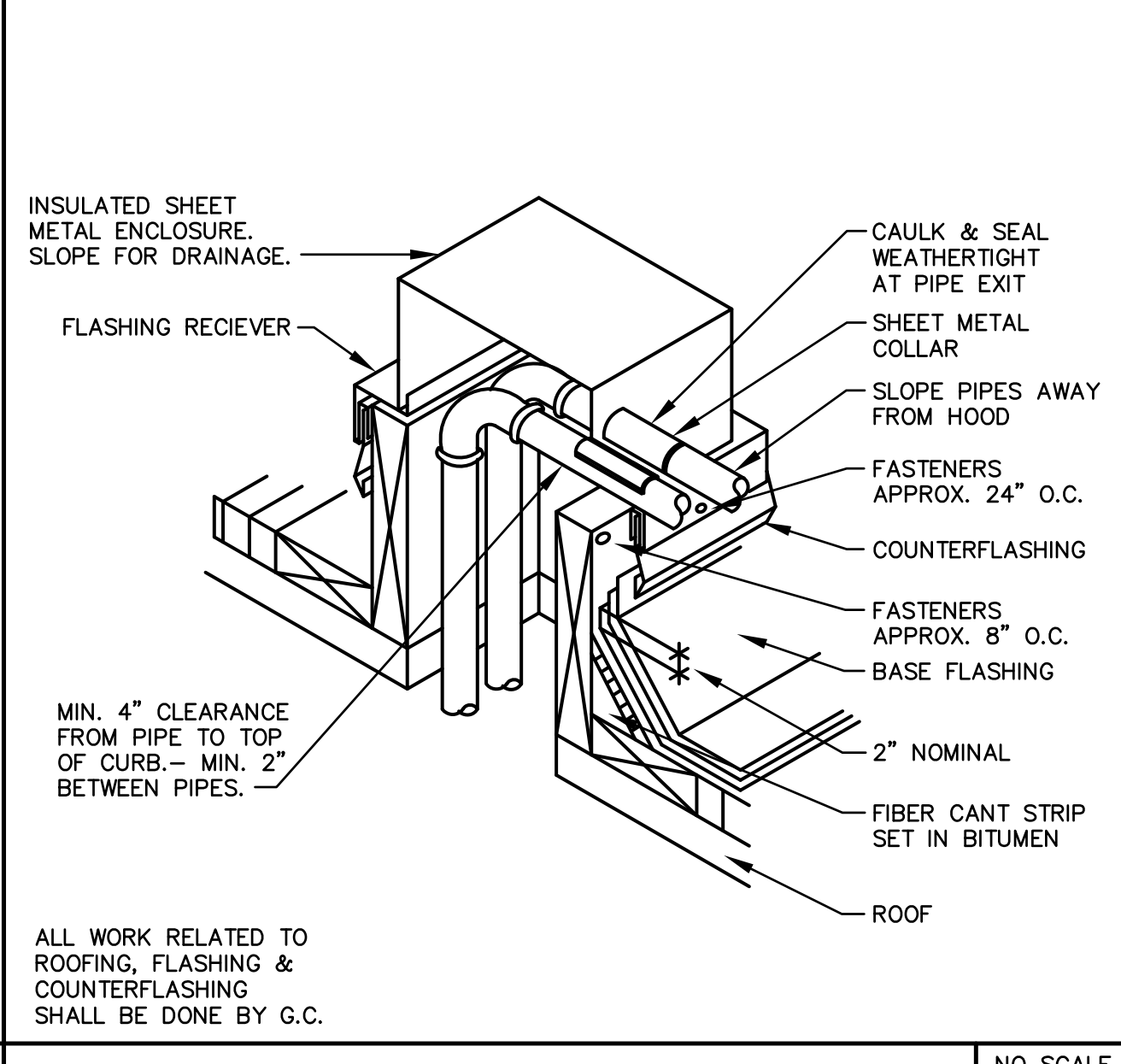

PIPING ROOF PENETRATION DETAIL

NO SCALE
15617-09

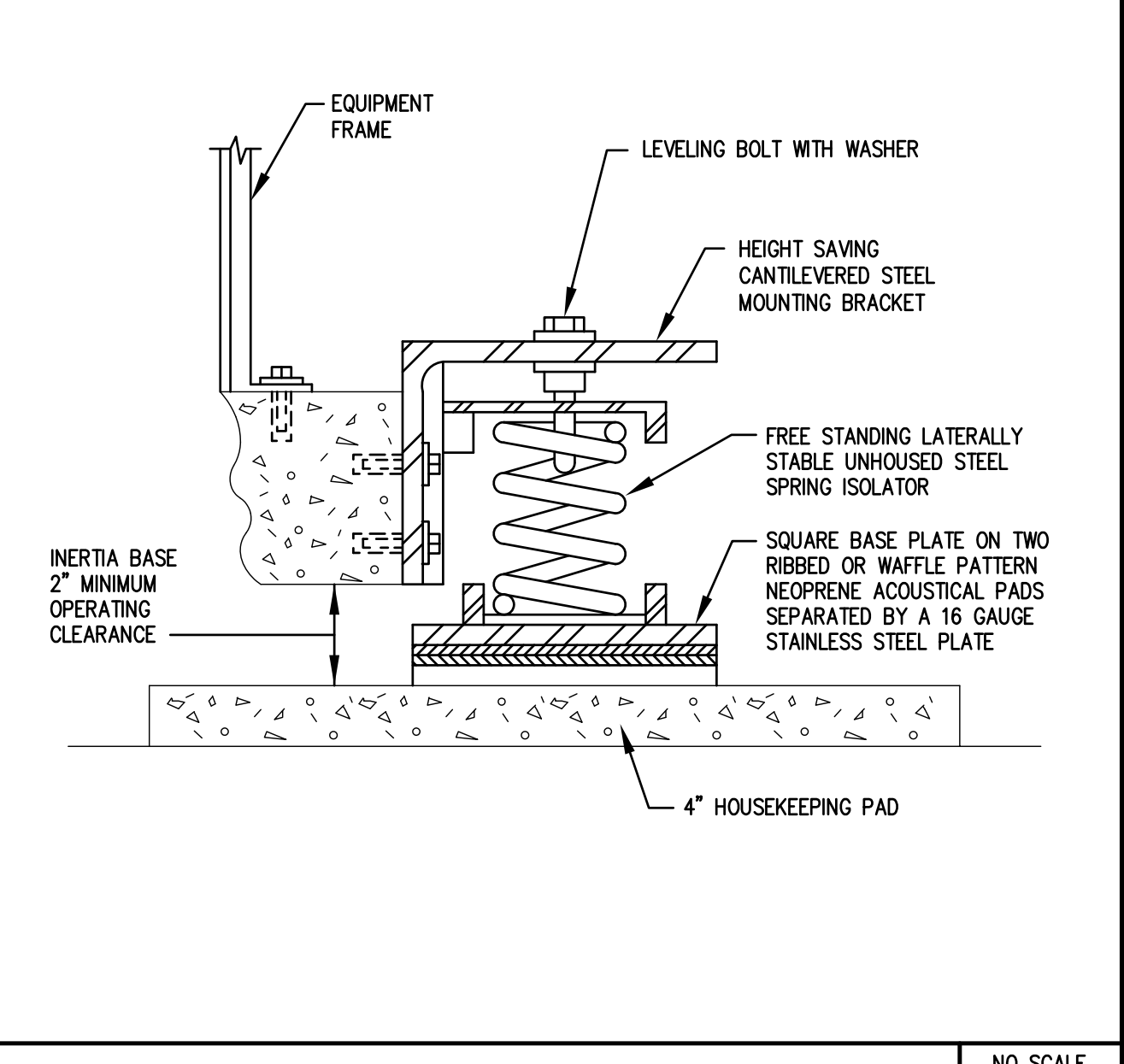

VIBRATION ISOLATOR DETAIL

NO SCALE
15607-01

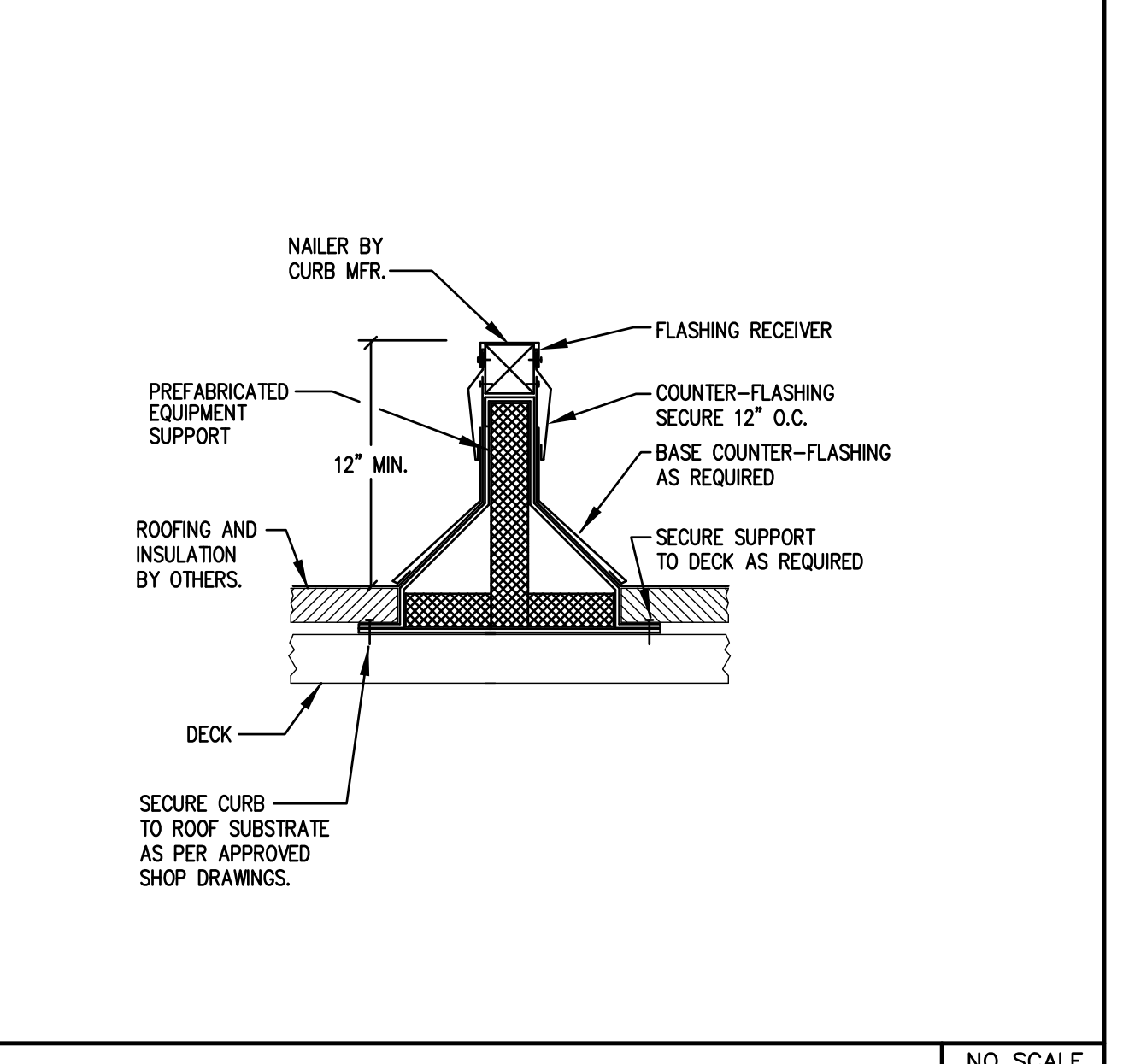

PRE-FABRICATED EQUIPMENT SUPPORT DETAIL

NO SCALE
15676-05

Maine Medical Center
Portland, Maine

MAINE MEDICAL CENTER
PAVILION 6 RENOVATIONS

MorrisSwitzer Project Number 28034
Date 11/19/09
Scale N.T.S.
Sheet Title and Number

SIXTH FLOOR PAVILIONS
"A" & "C" MECHANICAL
DETAILS II
3M4.1

