

**A1 TELEPHONE ALCOVE - PART. PLAN**  
SCALE: 1 1/2" = 1'-0"

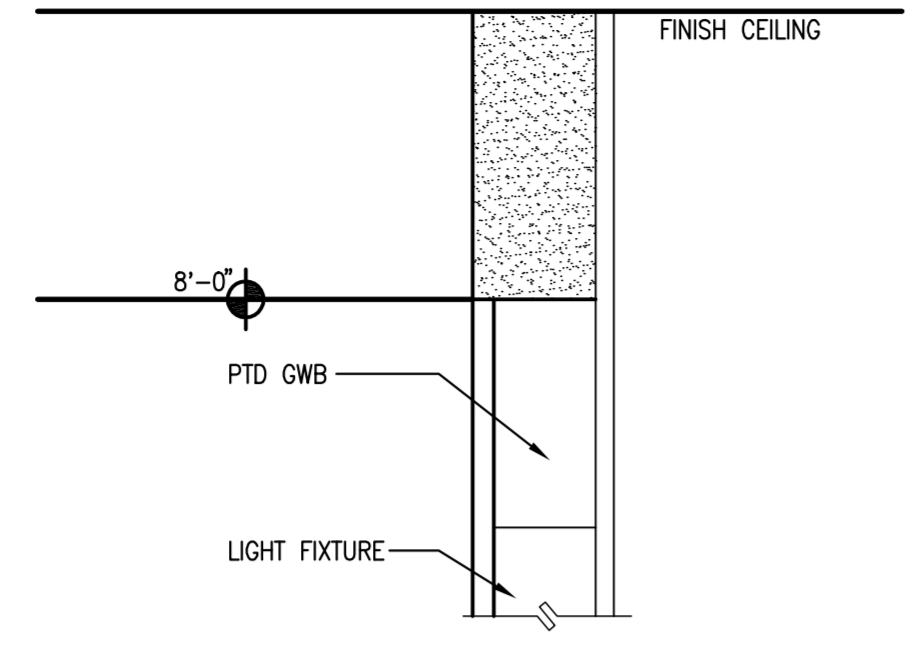

**C1 SECTION @ BANQUETTE**  
SCALE: 1-1/2" = 1'-0"

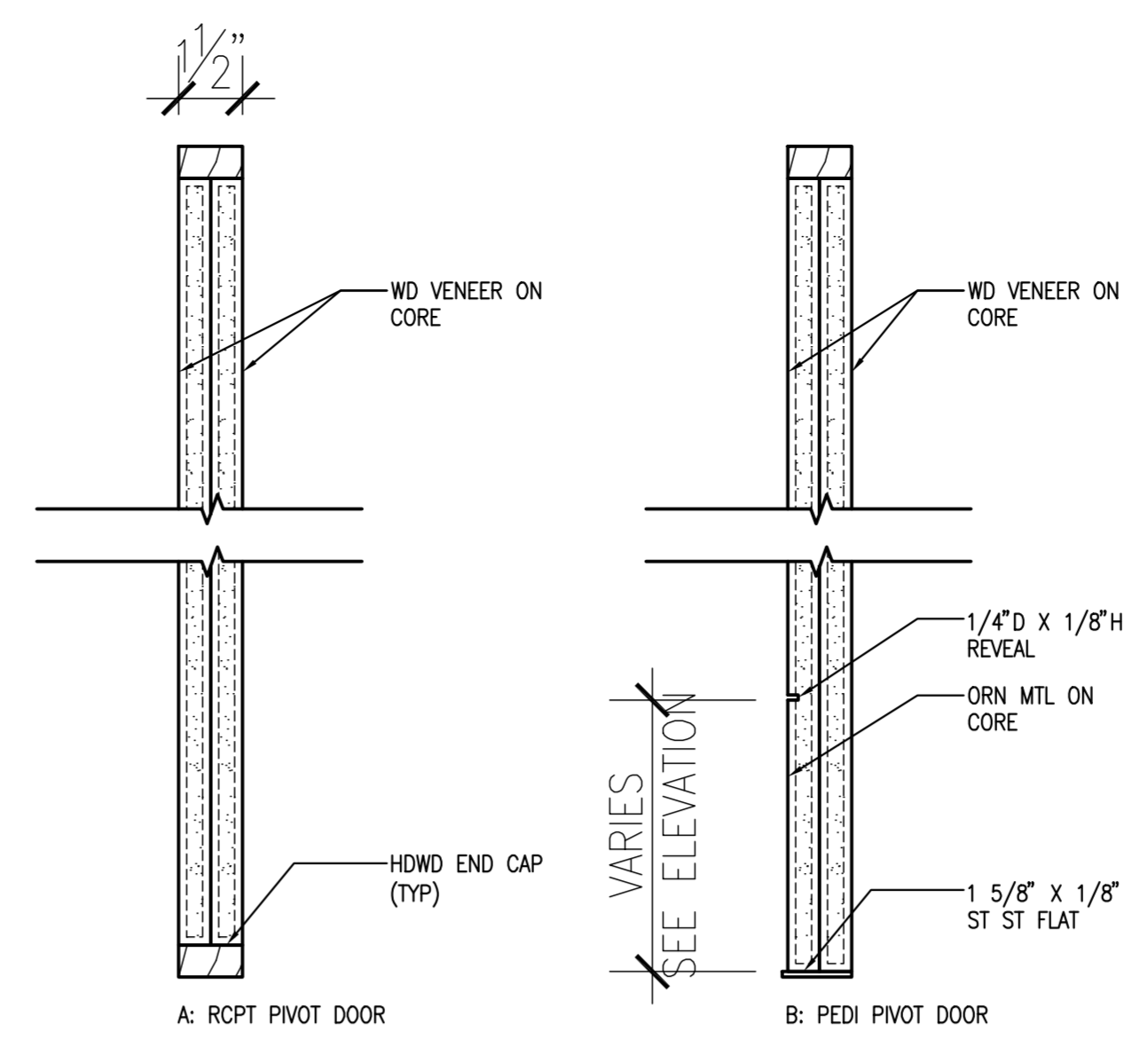

**D1 RECEPTION/ PEDI RECEPTION DOOR SECTION**  
SCALE: 3" = 1'-0"

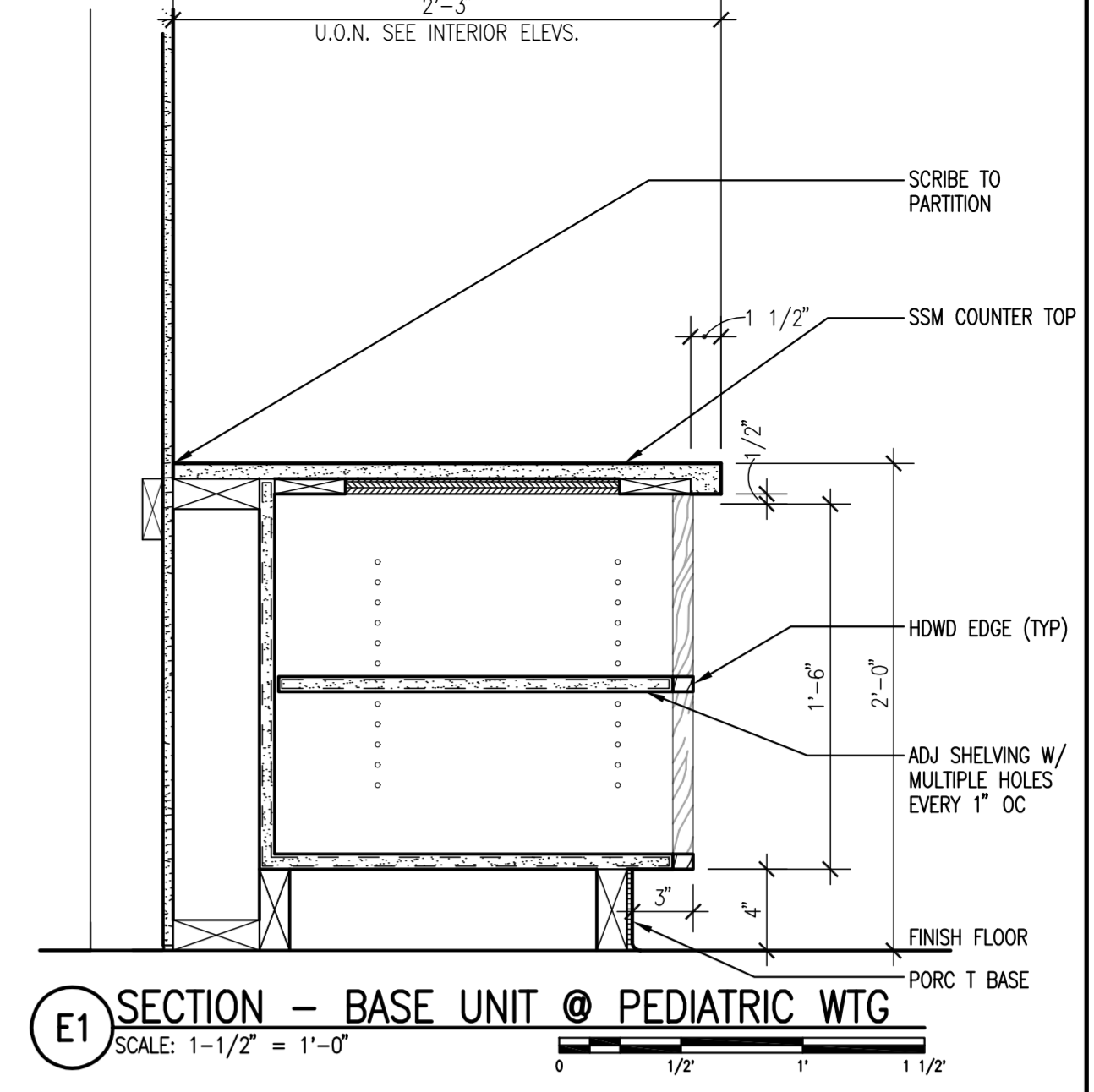

**E1 SECTION - BASE UNIT @ PEDIATRIC WTG**  
SCALE: 1-1/2" = 1'-0"

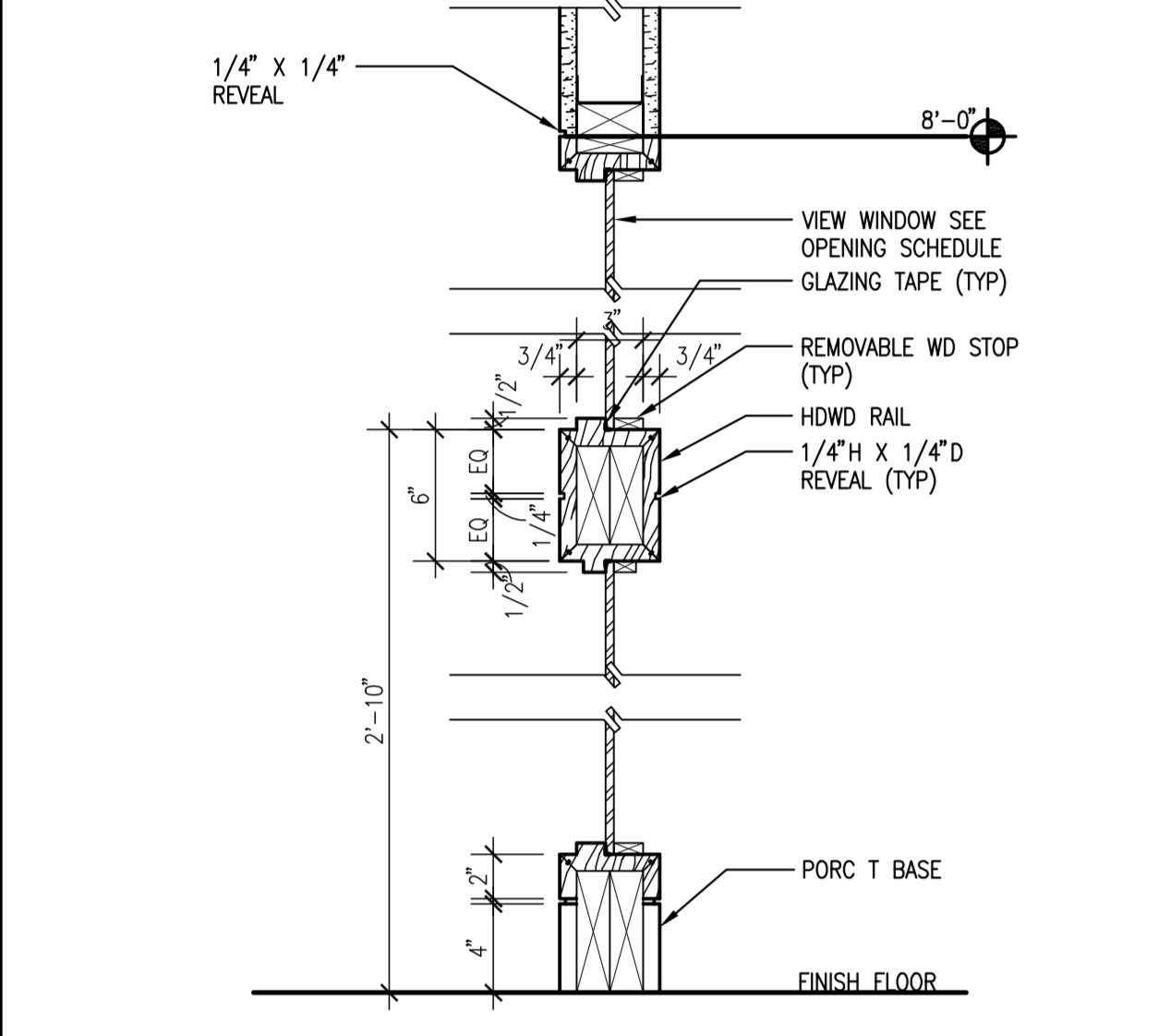

**A2 WOOD FRAMED BORROWED LIGHT**  
SCALE: 1 1/2" = 1'-0"

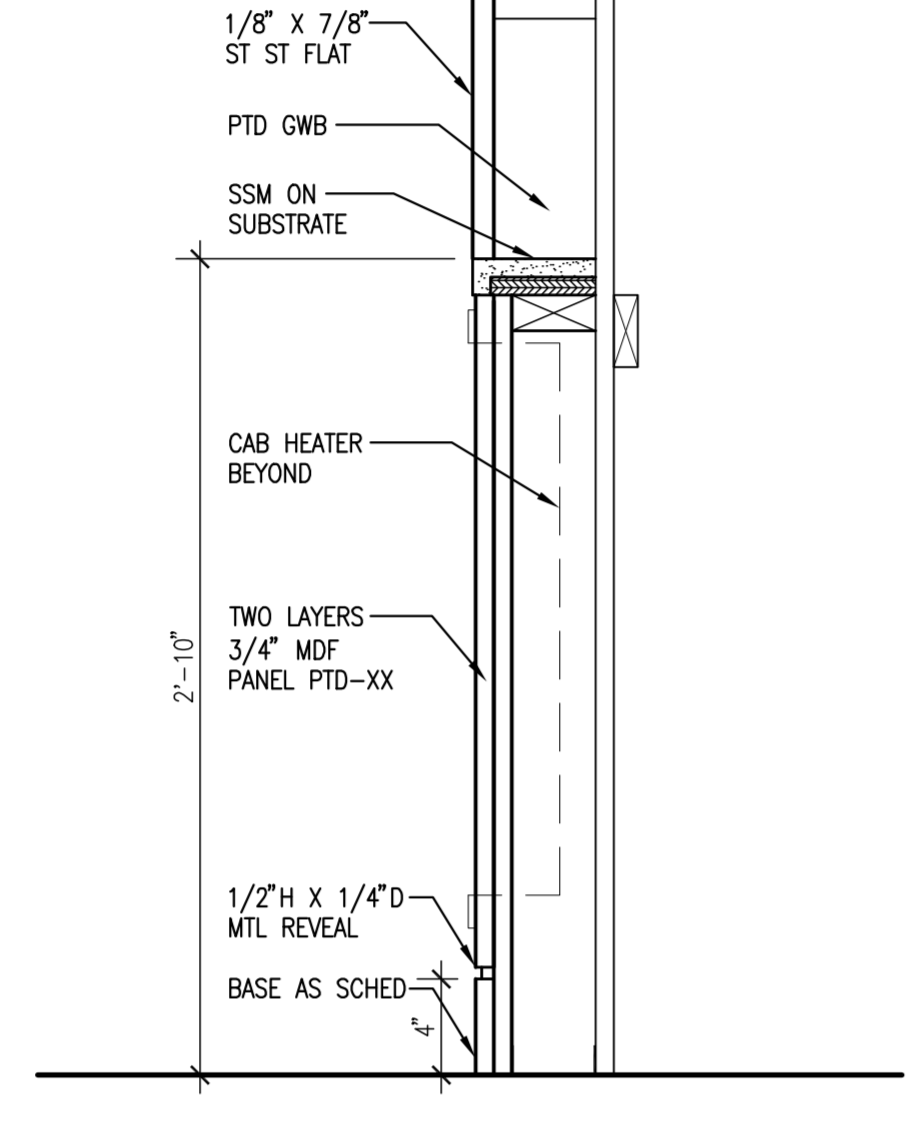

**B2 DECORATIVE SHELF WITH RECESSED LIGHT**  
SCALE: 1 1/2" = 1'-0"

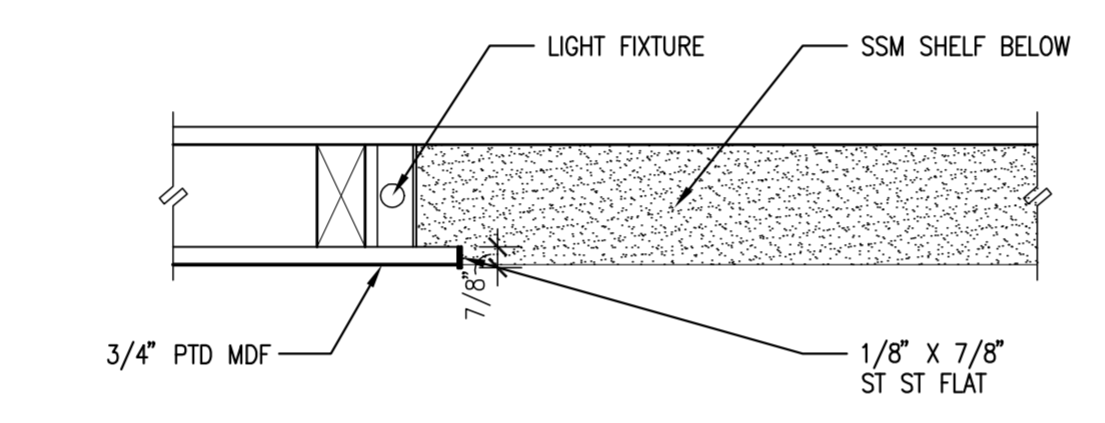

**C2 WALL AT MAIN RECEPTION DESK - PART. PLAN**  
SCALE: 1 1/2" = 1'-0"

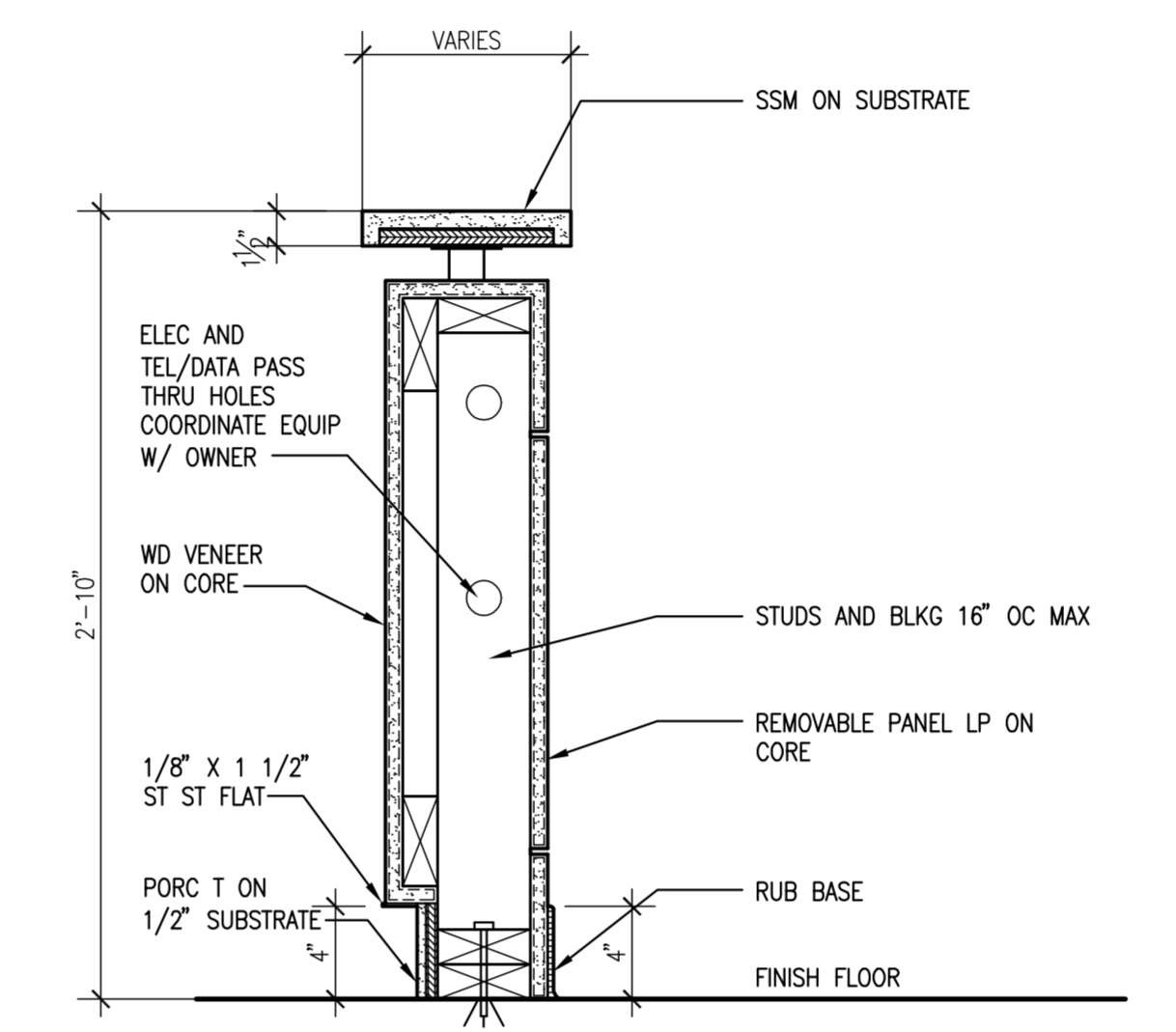

**D2 SECTION AT PEDIATRIC RECEPTION**  
SCALE: 1 1/2" = 1'-0"

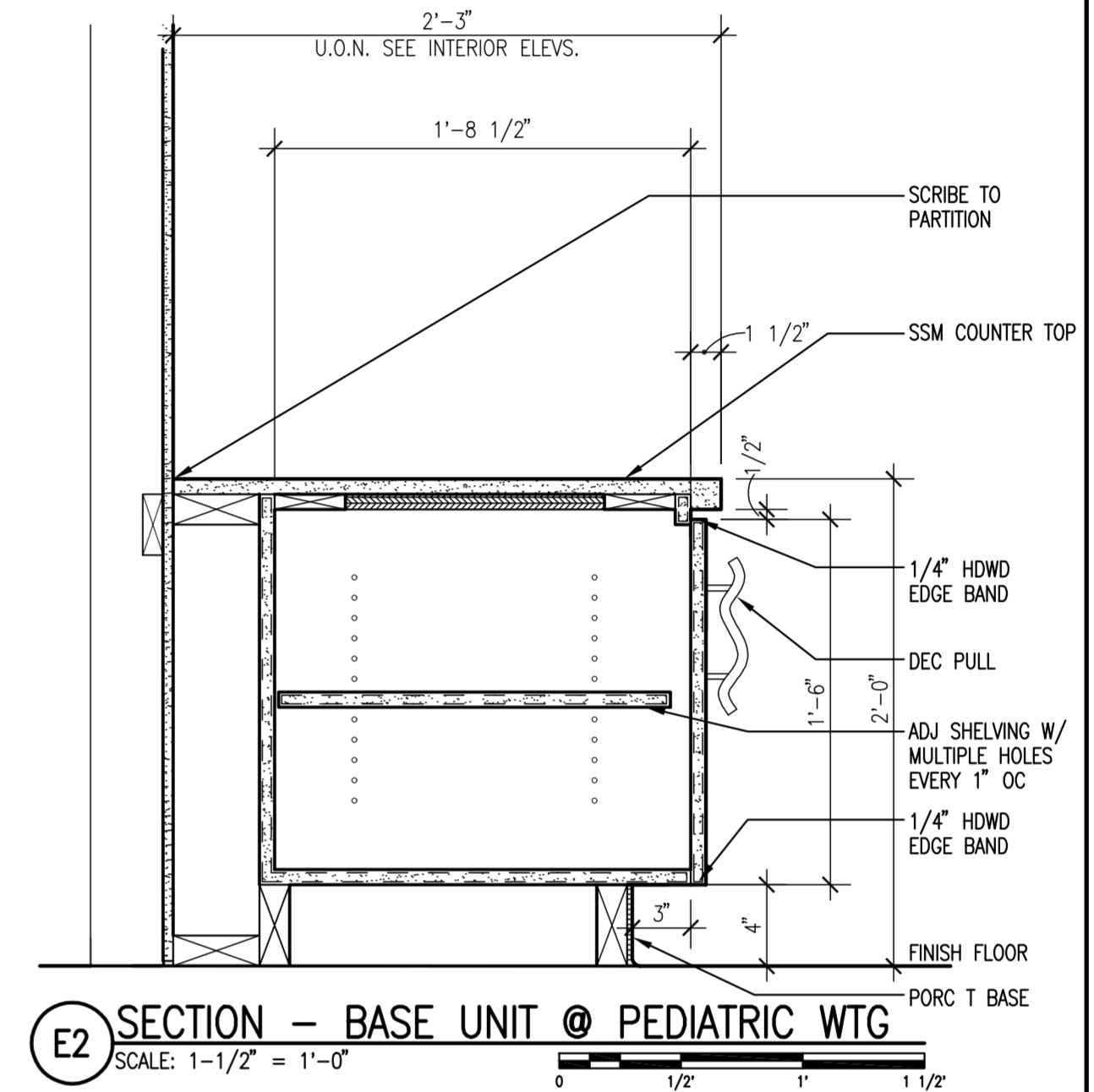

**E2 SECTION - BASE UNIT @ PEDIATRIC WTG**  
SCALE: 1-1/2" = 1'-0"

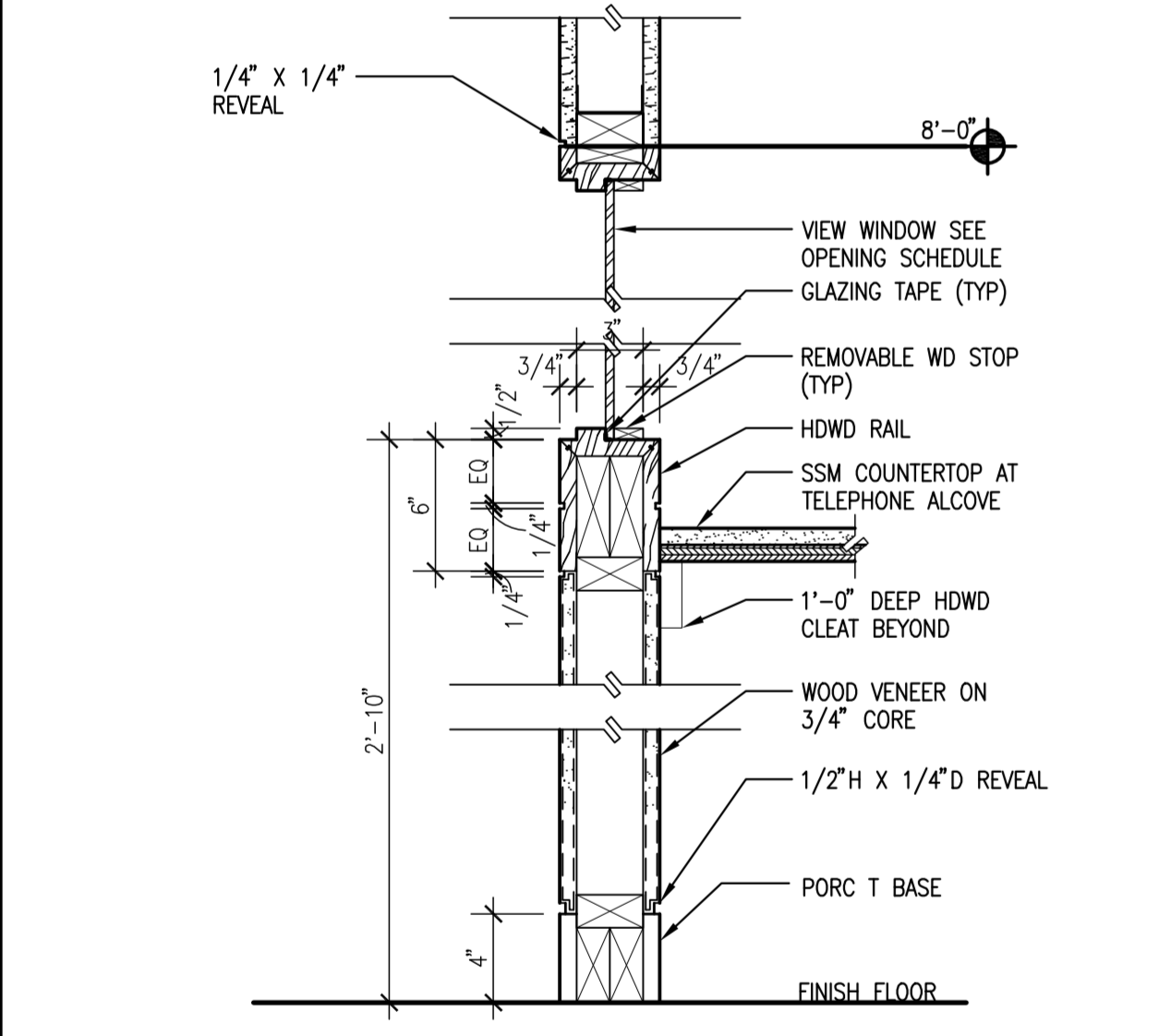

**A3 WOOD FRAMED BORROWED LIGHT**  
SCALE: 1 1/2" = 1'-0"

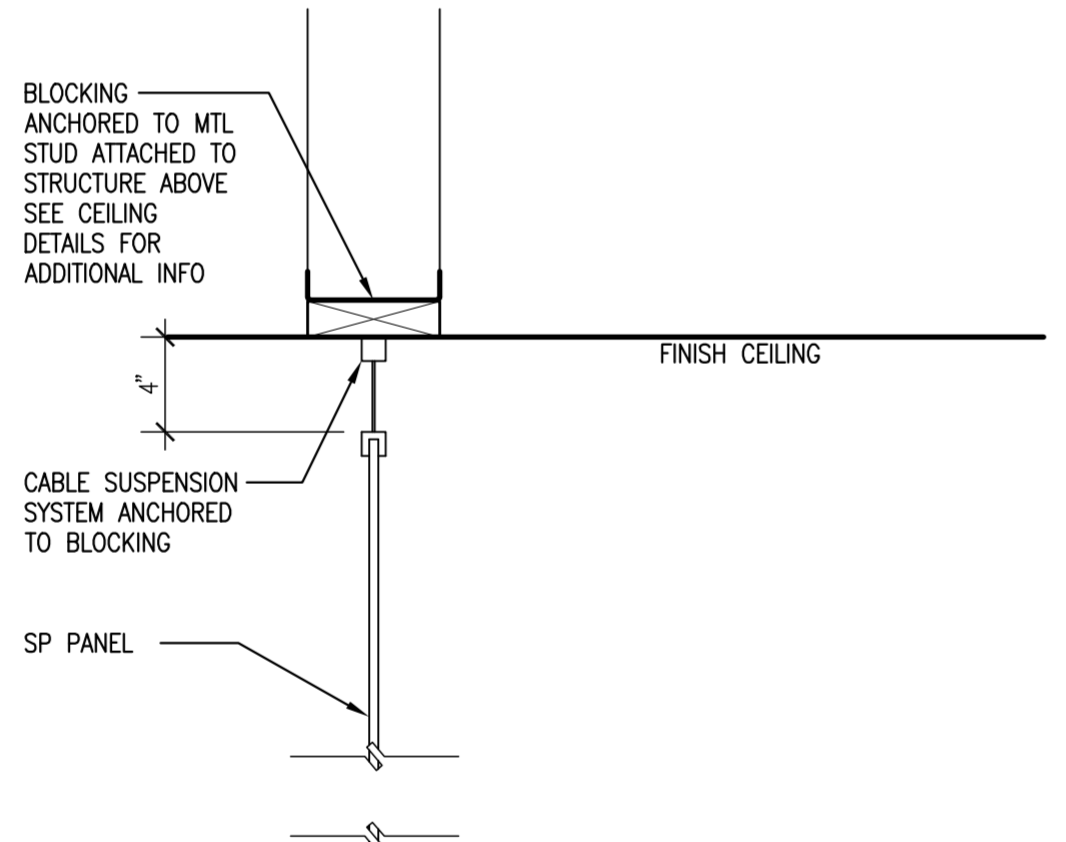

**B4 REGISTRATION WORK STATION**  
SCALE: 1 1/2" = 1'-0"

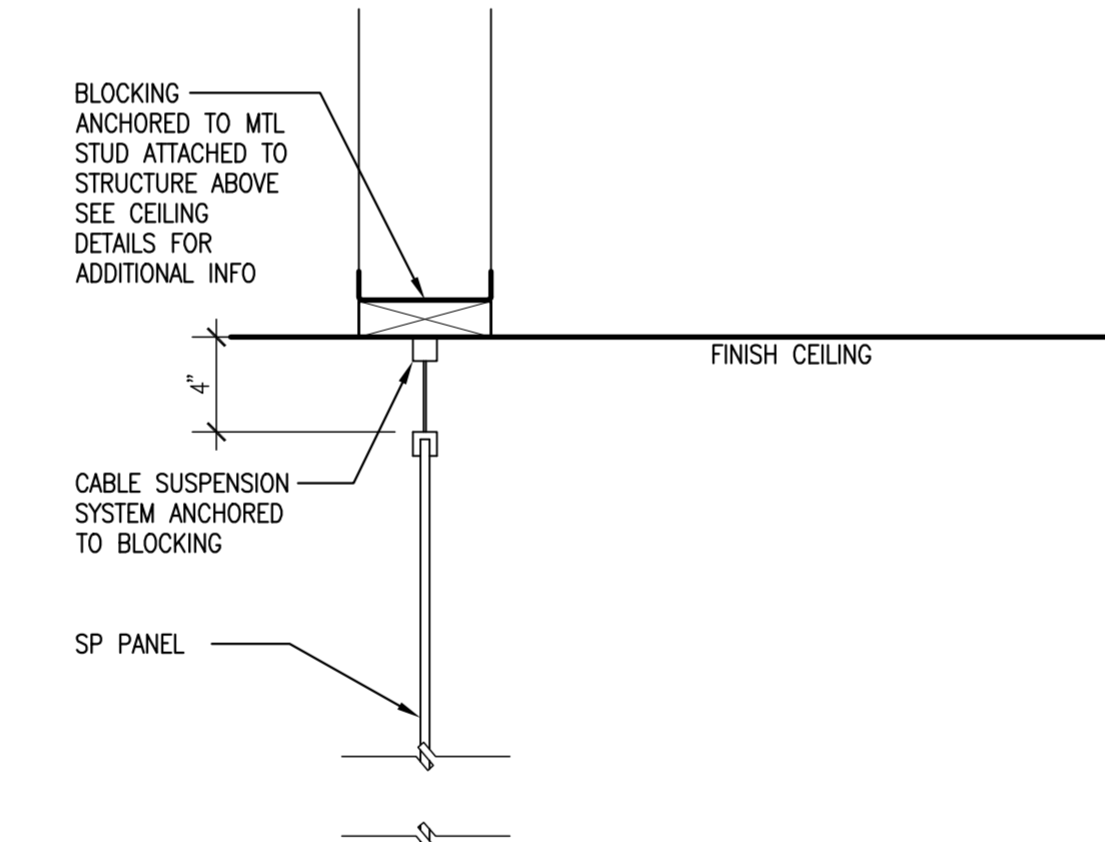

**C4 WHEELCHAIR ALCOVE**  
SCALE: 1 1/2" = 1'-0"

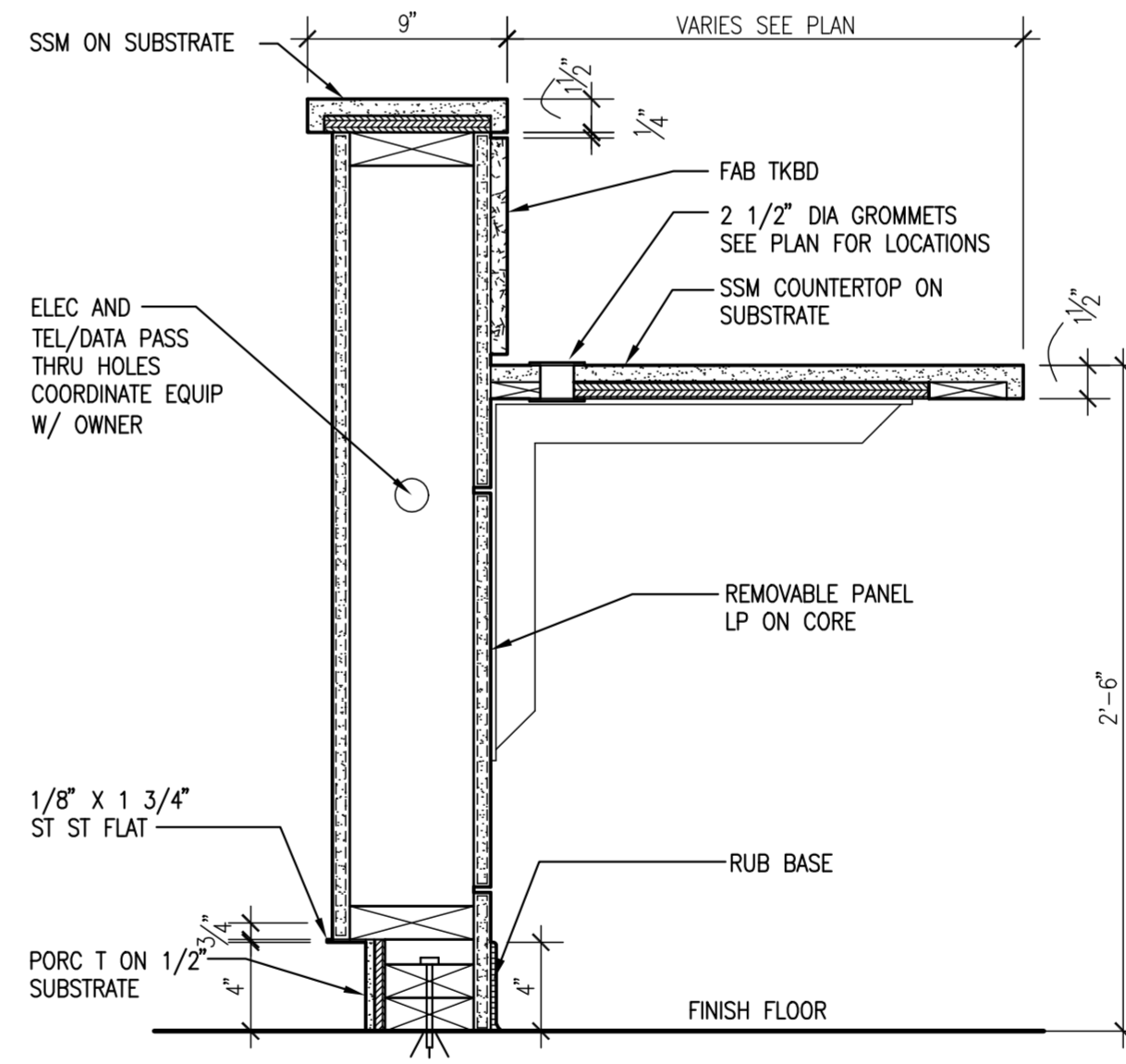

**D3 SECTION AT RECEPTION**  
SCALE: 1 1/2" = 1'-0"

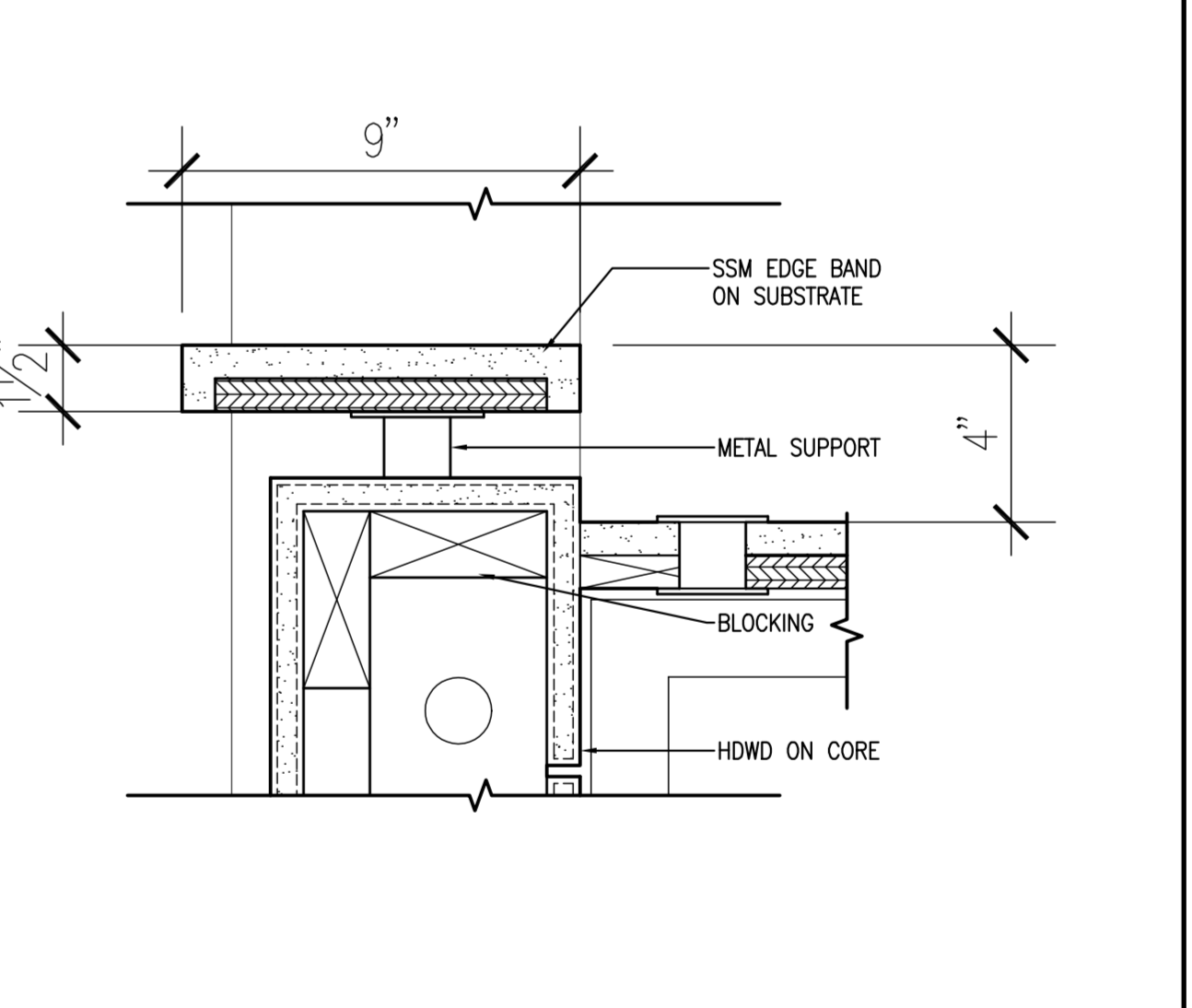

**E3 SECTION - STAFF STATION**  
SCALE: 3" = 1'-0"

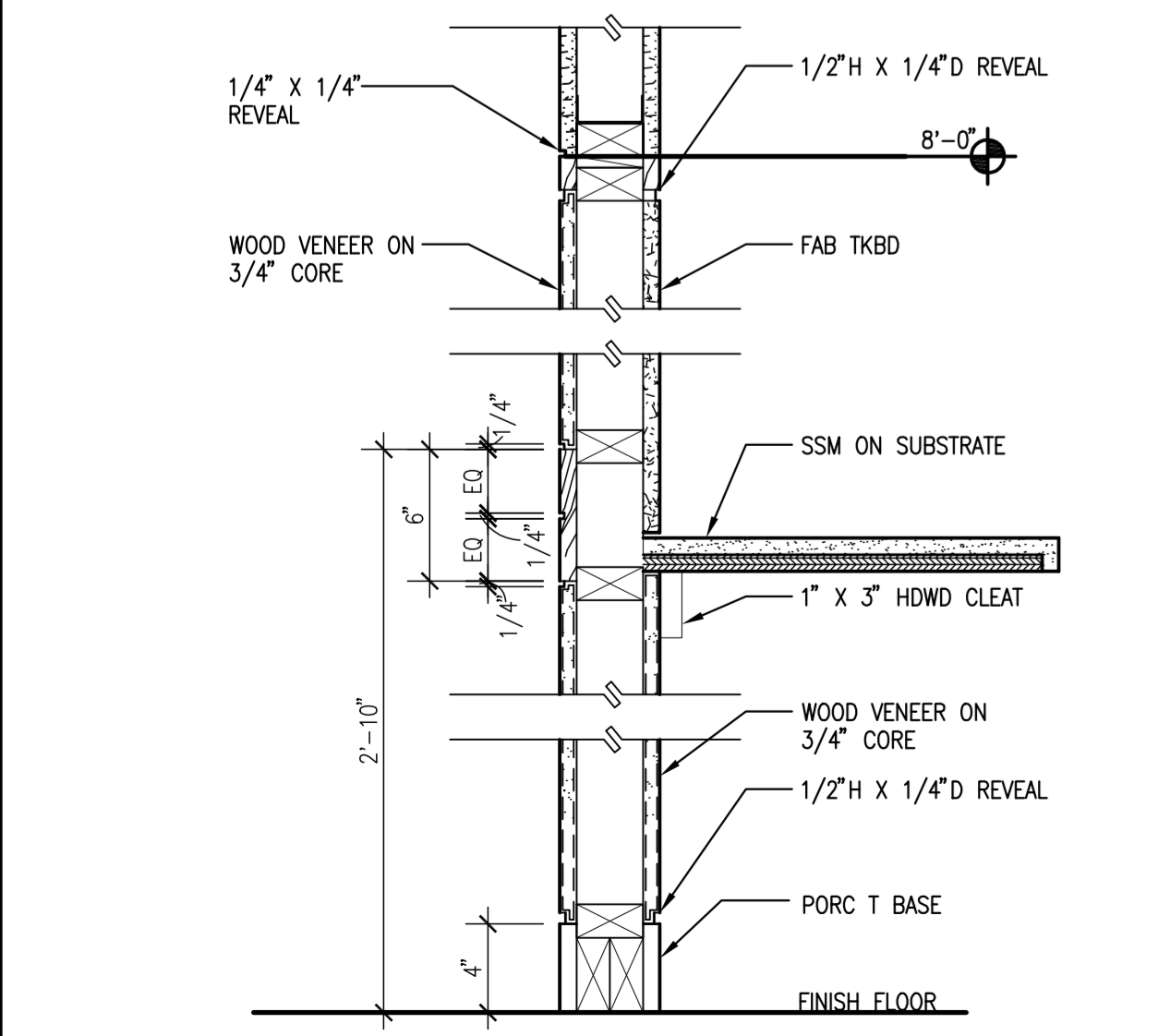

**A4 WOOD/FABRIC WRAPPED PANEL AT TELEPHONE**  
SCALE: 1 1/2" = 1'-0"

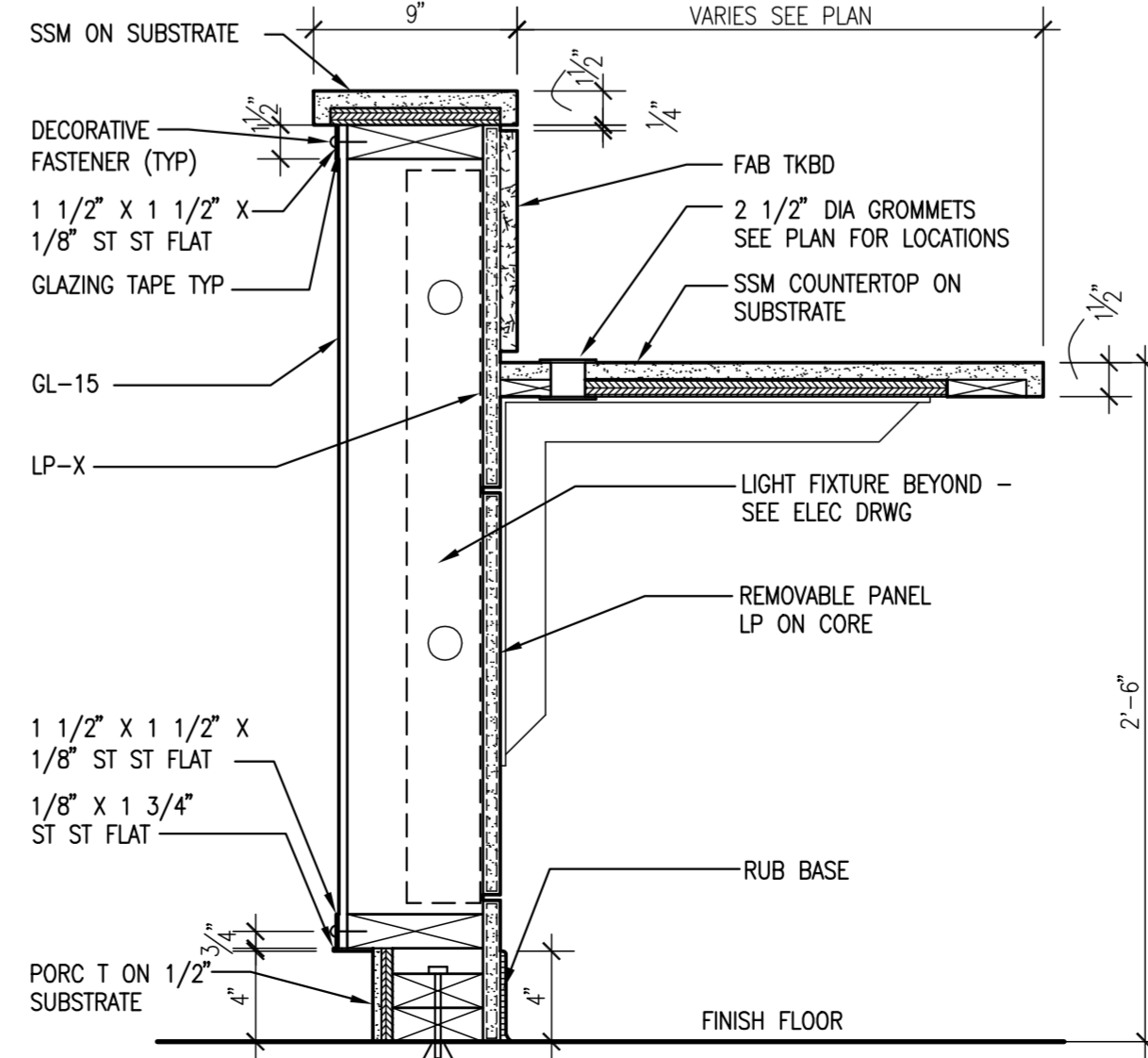
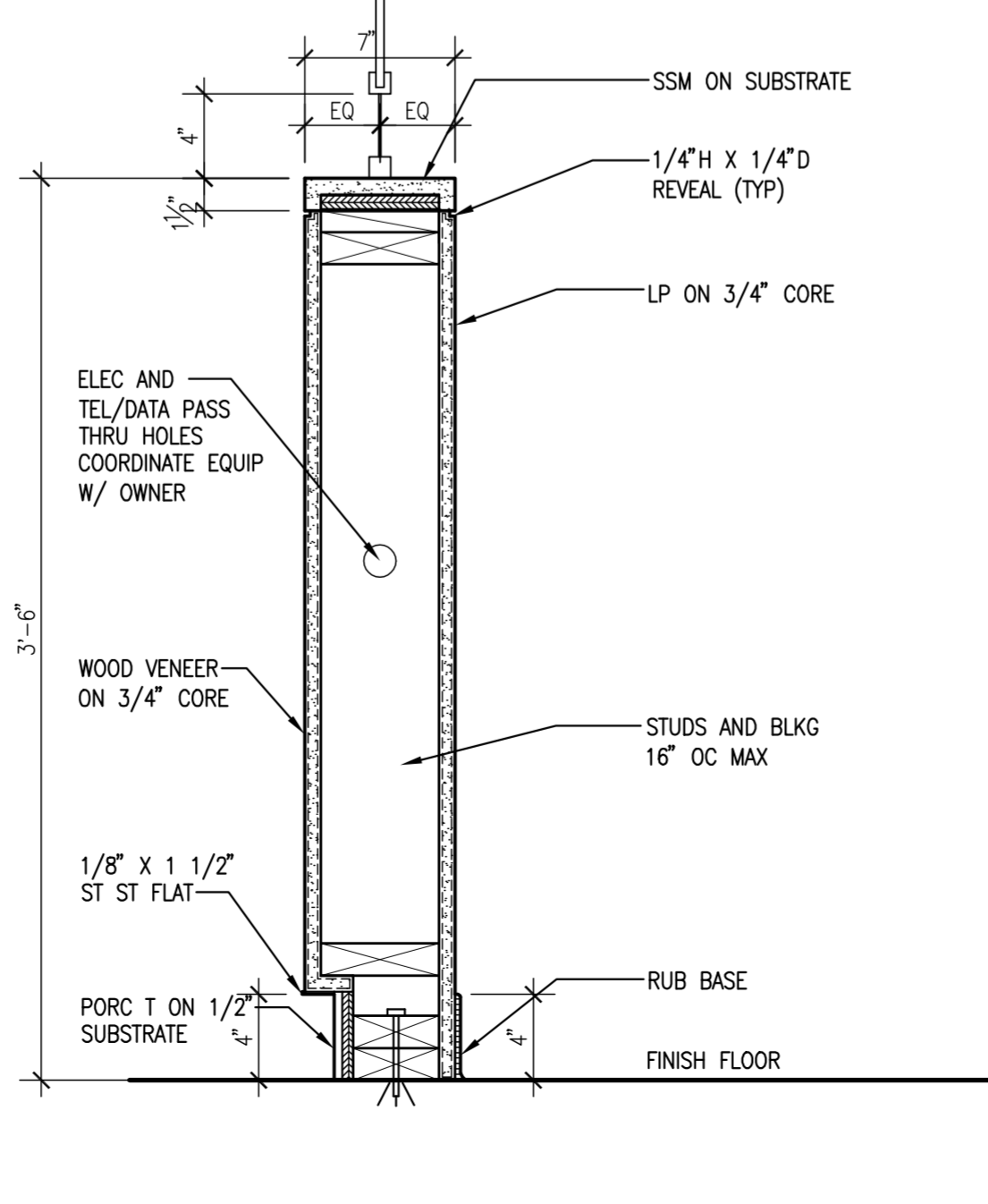
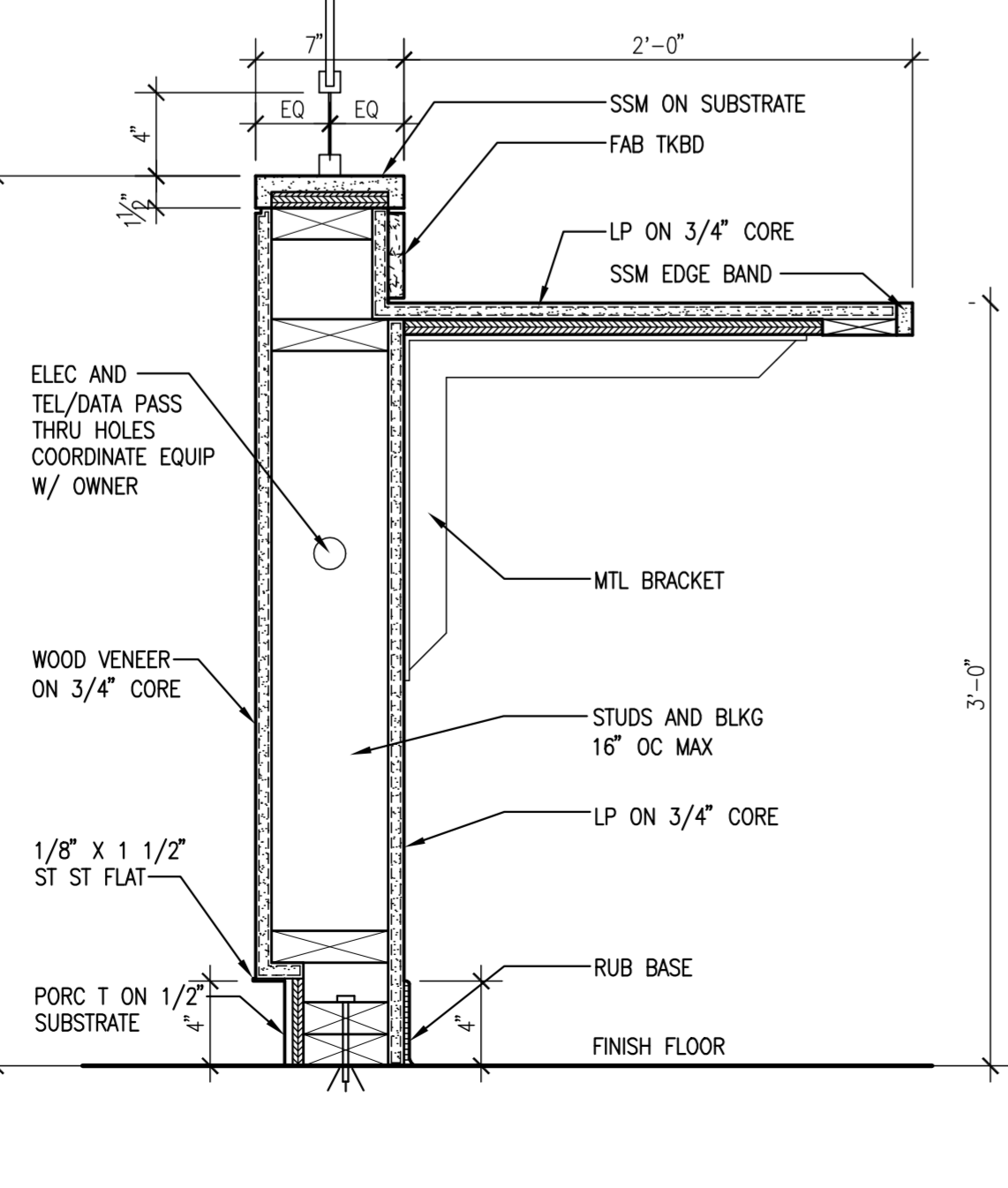

**D4 SECTION AT RECEPTION**  
SCALE: 1 1/2" = 1'-0"

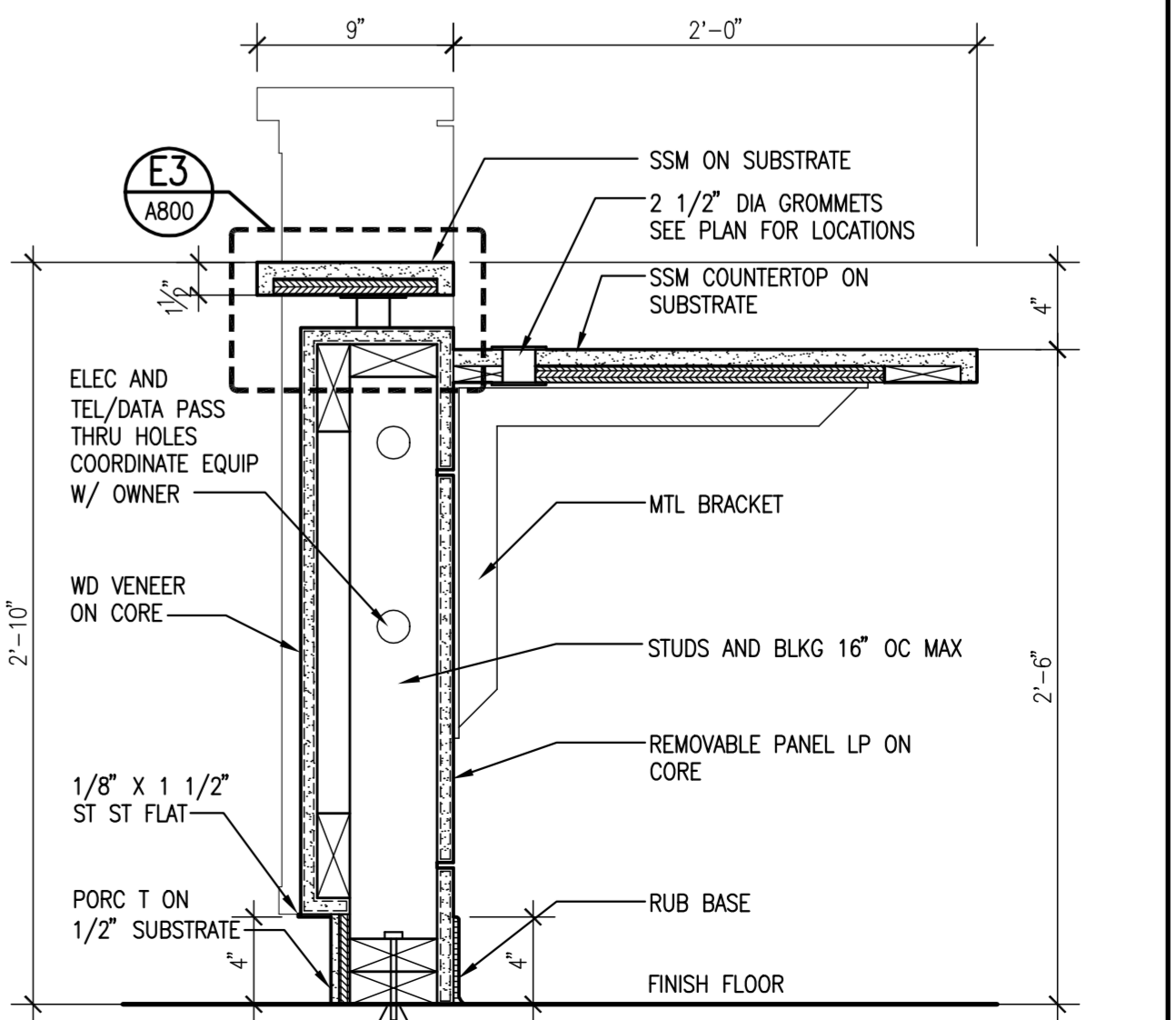

**E4 SECTION AT RECEPTION - ADA HEIGHT**  
SCALE: 1 1/2" = 1'-0"

MARK	ISSUE DATE	DESCRIPTION
BID	12/14/07	BID SET
Issue Log		

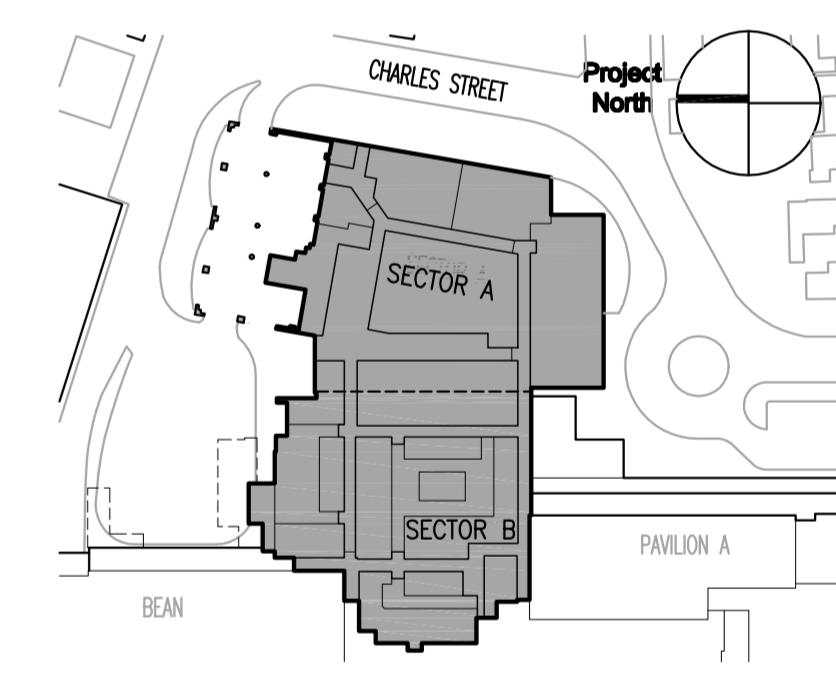

Key Plan

**TRO Jung|Brannen**  
ARCHITECTURE INTERIOR DESIGN ENGINEERING MASTER PLANNING  
22 Boston Wharf Road, Boston, Massachusetts 02210  
Tel 617.502.8400 Fax 617.502.3402 www.trojungbrannen.com

**Maine Medical Center**  
ED Expansion and Renovation  
Portland, Maine MMC Project No. 21843

Drawing Title	<b>MAIN LOBBY CASEWORK DETAILS</b>		
Drawing Scale	JET	Commission No.	4696
Drawn By	AF	Date Issued	12/14/07
Approved By	AF		

Phase / Package Number Sheet Number  
**A800**