

4.0 Addressable Devices

Item No.	Description	Data Sheet Part Number	Data Sheet Label
4.1	Intelligent Bases	B210LP	HON-AD-001
4.2	Intelligent Photoelectric Smoke Detectors	TC806DNR, TC806B1076	HON-AD-002
4.3	Thermal Detectors	TC808B1058	HON-AD-003
4.4	Monitor Modules	TC809A1059	HON-AD-004
4.5	Relay/Control Module	TC810R1024, TC810N1013	HON-AD-005
4.6	Six Relay Control Module	XP6-R, CHS-6	HON-AD-006
4.7	Six Circuit Multi Control Module	XP6-C, CHS-6	HON-AD-007
4.8	Addressable Manual Pull Station	S464G1007	HON-AD-008

Intelligent Bases

B501(A), B200S(A), B200SR(A), B210LP(A), B2241BI(A), B224RB(A), Mounting Kits, and Accessories

General

Intelligent FlashScan® and CLIP mounting bases and kits provide a variety of ways to install Honeywell detectors in any application. Intelligent detectors can be mounted in either flanged or flangeless bases depending on junction box selection (see *Junction Box Selection Guide*). Across this product line, detectors plug in easily to the base with SEMS screws; and models employ various 12 to 24 AWG wire ranges.

Relay, isolator, and sounder bases can be used to meet local code requirements. Relay bases provide one Form-C contact relay for control of auxiliary functions such as door closure and elevator recall. Isolator bases allow loops to continue to operate under fault conditions and automatically restore when the fault is removed. Sounder bases are available in temporal and non-temporal pattern versions depending on whether the signal is to be used for evacuation purposes.

Specifications

Diameter:

- B501: 4.1" (104 mm).
- B224BI, B224RB, B210LP: 6.1" (155 mm).
- B200S/SR: 6.875" (17.46 cm).

Wire gauge:

- B224BI, B224RB: 14 to 24 AWG.
- B210LP, B501, B200S/SR: 12 to 24 AWG.

Temperature range:

- B224BI, B224RB, B200S/SR: 32°F to 120°F (0°C to 49°C).
- B210LP, B501: -4°F to 150°F (-20°C to 66°C).

Humidity range: 10% to 93% RH, non-condensing.

System temperature and humidity ranges: This system meets NFPA requirements for operation at 0°C to 49°C (32°F to 120°F); and at a relative humidity (noncondensing) of 85% at 30°C (86°F) per NFPA, and 93% ± 2% at 32°C ± 2°C (89.6°F ± 1.1°F) per ULC. However, the useful life of the system's standby batteries and the electronic components may be adversely affected by extreme temperature ranges and humidity. Therefore, it is recommended that this system and all peripherals be installed in an environment with a nominal room temperature of 15°C to 27°C (60°F to 80°F).

Electrical Ratings

FOR B200S/SR:

External supply voltage: 16 to 33 VDC (VFWR)

Standby current: 500 µA maximum.

Alarm current:

- B200S: 25 mA maximum at high-volume setting; 15 mA maximum at low-volume setting.
- B200SR: 35 mA maximum.

SLC operating voltage: 15 to 32 VDC.

SLC standby current: 300 µA.

Sound output: measured in a UL reverberant room at 10 feet, 24 Volts (continuous tone).

- B200S, high-volume: Greater than 85 dBA minimum.
- B200S, low-volume: Greater than 75 dBA minimum.
- B200SR: Greater than 85 dBA minimum.



Flangeless Mounting Base
B501(A)



Flanged Mounting Base
B210LP(A)



Sounder Base
B200S(A), B200SR(A)



Relay Base
B224RB(A)

FOR B224RB, B224BI:

Operating voltage: 15 to 32 VDC (powered by SLC).

Standby ratings: <500 µA maximum @ 24 VDC.

Set time (B224RB only): short delay 55 to 90 msec; long delay 6 to 9 seconds.

Reset time (B224RB only): 20 msec maximum.

Relay characteristics (B224RB only): two-coil latching relay; one Form-C contact; ratings (UL/CSA): 0.9 A @ 125 VAC, 0.9 A @ 110 VDC, and 3.0 A @ 30 VDC.

Product Line Information

INTELLIGENT BASES

B501: Flangeless mounting base.

B501A: Flangeless mounting base, ULC Listed.

B501BP: Bulk pack of B501 (10).

B210LP: Flanged mounting base.

B210LPA: Flanged mounting base, ULC listed

B210LPBP: Bulk pack of B210LP (10).

B200S: Intelligent addressable sounder base capable of producing sound output in high or low volume with ANSI Temporal 3, ANSI Temporal 4, continuous tone, marching tone, and custom tone.

B200SA: Same as B200S with ULC-listing.

B200SR: Intelligent sounder base capable of producing sound output with ANSI Temporal 3 or continuous tone.

B200SRA: Same as B200SR with ULC-listing.

B224RB: Relay base.

B224RBA: Relay base, ULC Listed.

B224BI: Isolator base.

B224BIA: Isolator base, ULC Listed.

MOUNTING KITS AND ACCESSORIES

SMB600: Surface mounting kit, flanged.

F110: Retrofit flange for converting high-profile bases to low-profile.

F110BP: Bulk pack of F110 (10).

F210: Accessory flange ring for B210LP(A) base (new design). 6-inch diameter.

F210BP: Bulk pack of F210 (10).

RA100Z: Remote LED annunciator.

RA100ZA: Remote LED annunciator, ULC Listed.

M02-04-00: Detector test magnet.

M02-09-00: Test magnet with telescoping handle.

XR2B: Detector removal tool for current heads (T55-127-010 included).

XR2: Detector Remove Tool for use with low profile detector heads, and TC846A1013/TC846A1005.

XP-4: Extension pole for XR2/B (5 to 15 ft/1.524 to 4.572 m).

T55-127-010: Detector removal head.

BCK-200B: Black detector kit, package of 10 (for use with photo and ion detectors).

WCK-200B: White detector kit, package of 10 (for use with photo and ion detectors).

Agency Listings and Approvals

The listings and approvals below apply to intelligent bases as noted. In some cases, certain modules or applications may not be listed by certain approval agencies, or listing may be in process. Consult factory for latest listing status.

- **UL Listed:** S911
- **ULC Listed:** S911
- **FM Approved**
- **MEA:** 22-95-E, 205-94-E Vol. 2; 257-06-E
- **CSFM:** 7300-1130:131, 7300-1653:0126, 7135-1653:0213, 7300-1653:0109

Junction Box Selection Guide

Base Models	Single Gang	3.5" Oct.	4.0" Oct.	4.0" Sq.	4.0" Sq. with 3.0" mud ring	50 mm	60 mm	70 mm	75 mm
B200S, B200SR	Yes	Yes	Yes	Yes	Yes	No	No	No	No
B501	No	Yes	No	No	Yes	Yes	Yes	Yes	No
B210LP	Yes	Yes	Yes	Yes	Yes	No	No	No	No
B224RB	No	Yes	Yes	Yes	No	No	Yes	Yes	Yes
B224BI	No	Yes	Yes	Yes	No	No	No	Yes	Yes

NOTE: Box depth contingent on base and wire size.
Refer to National Electric Code or applicable local codes for appropriate recommendations.

This document is not intended to be used for installation purposes. We try to keep our product information up-to-date and accurate. We cannot cover all specific applications or anticipate all requirements. All specifications are subject to change without notice.

FlashScan® and System Sensor® are registered trademarks of Honeywell International Inc.

©2011 by Honeywell International Inc. All rights reserved. Unauthorized use of this document is strictly prohibited.

Automation and Control Solutions

Honeywell International Inc.
1985 Douglas Drive North
Golden Valley, MN 55422
www.honeywell.com

Honeywell Limited-Honeywell Limitée
35 Dynamic Drive
Scarborough, Ontario M1V 4Z9

85-3043-4 Rev. 07-11
July 2011
Made in the U.S.A.
© U.S. Registered Trademark
© 2011 Honeywell International Inc.
Page 2 of 2



85-3043-4

Honeywell

TC806B1076(CDN), TC806B1084, TC806DNR(CDN)

Intelligent Plug-In Photoelectric Smoke Detectors with FlashScan®

General

Honeywell intelligent plug-in smoke detectors with integral communication provide features that surpass conventional detectors. Detector sensitivity can be programmed in the control panel software. Sensitivity is continuously monitored and reported to the panel. Point ID capability allows each detector's address to be set with rotary, decimal address switches, providing exact detector location for selective maintenance when chamber contamination reaches an unacceptable level. The TC806B1076(CDN) photoelectric detector's unique optical sensing chamber is engineered to sense smoke produced by a wide range of combustion sources. Dual electronic thermistors add 135°F (57°C) fixed-temperature thermal sensing on the TC806B1084(CDN). The TC806B1084(CDN) is a remote test capable detector for use with DNR(A)/DNRW duct detector housings. TC806DNR(CDN) and TC806B1084(CDN) detectors are compatible with Honeywell XLS series Fire Alarm Control Panels (FACPs) in CLIP or FlashScan® mode.

FlashScan® (U.S. Patent 5,539,389) is a communication protocol that greatly increases the speed of communication between analog intelligent devices. Intelligent devices communicate in a grouped fashion. If one of the devices in the group has new information, the panel's CPU stops the group poll and concentrates on single points. The net effect is response speed greater than five times that of earlier designs.

Features

- Sleek, low-profile design.
- Addressable-analog communication.
- Stable communication technique with noise immunity.
- Low standby current.
- Two-wire SLC connection.
- Compatible with FlashScan® and CLIP protocol systems. (XLS140-2, XLS120, XLS3000, XLS1000, and FS90 Plus)
- Rotary, decimal addressing (1-99 on CLIP systems, 1-159 on FlashScan systems).
- Optional remote, single-gang LED accessory.
- Dual LED design provides 360° viewing angle.
- Visible bi-color LEDs blink green every time the detector is addressed, and illuminate steady red on alarm (*FlashScan systems only*).
- Remote test feature from the panel.
- Walk test with address display (an address on 121 will blink the detector LED: 12-[pause]-1 (*FlashScan systems only*)).
- Built-in functional test switch activated by external magnet.
- Built-in tamper-resistant feature.
- Sealed against back pressure.
- Constructed of off-white fire-resistant plastic, designed to commercial standards, and offers an attractive appearance.
- 94-5V plastic flammability rating.
- SEMS screws for wiring of the separate base.
- Optional relay, isolator, and sounder bases.



TC806B1076 in B210LP(A) Base

B210-29951.jpg

Specifications

Sensitivity: 0.5% to 2.35% per foot obscuration

Size: 2.1" (5.3 cm) high; base determines diameter.

- **B210LP(A):** 6.1" (15.5 cm) diameter.
- **B501(A):** 4.1" (10.4 cm) diameter.
- **B200S(A):** 6.875" (17.46 cm) diameter.
- **B200SR(A):** 6.875" (17.46 cm) diameter.
- **B224RB(A):** 6.2" (15.748 cm) diameter.
- **B224BI(A):** 6.2" (15.748 cm) diameter.

Shipping Weight: 5.2oz. (147g).

Operating Temperature range: TC806B1076(CDN), 0°C to 49°C (32°F to 120°F). TC806B1084(CDN), 0°C to 38°C (32°F to 100°F). Low temperature signal for TC806B1084(CDN) at 45°F +/- 10°F (7.22°C +/- 5.54°C). TC806B1084(CDN) installed in a DNR(A)/DNRW, -20°C to 70°C (-4°F to 158°F).

UL/ULC Listed Velocity Range: 0-4000 ft/min. (1219.2 m/min.), suitable for installation in ducts.

Relative Humidity: 10%-93% noncondensing.

Thermal Ratings: Fixed-temperature setpoint 135°F (57°C).

DETECTOR SPACING AND APPLICATIONS

Honeywell recommends spacing detectors in compliance with NFPA 72. In low airflow applications with smooth ceiling, space detectors 30 feet (9.144m) for ceiling heights 10 feet (3.148m) and higher. For specific information regarding detector spacing, placement, and special applications refer to NFPA 72. *System Smoke Detector Application Guide*, document A05-1003, is available at systemsensor.com

ELECTRICAL SPECIFICATIONS

Voltage Range: 15-32 volts DC peak.

Standby Current (max. avg.): 300µA @ 24VDC (one communication every five seconds with LED enabled).

LED Current (max.): 6.5mA @ 24 VDC ("ON").

Installation

TC806B1076(CDN) plug-in detectors use a separate base to simplify installation, service, and maintenance. A special tool allows maintenance personnel to plug in and remove detectors without using a ladder.

Mount base (all base types) on an electrical backbox which is at least 1.5" (3.81 cm) deep. For a chart of compatible junction boxes, see 85-3043.

NOTE: 1) Because of inherent supervision provided by the SLC loop, end-of-line resistors are not required. Wiring "T-taps" or branches are permitted for Style 4 (Class "B") wiring. 2) When using relay or sounder bases, consult the TC811A1006(CDN)

installation sheet I56-1385 for device limitations between isolator modules and isolator bases.

Agency Listings and Approvals

These listings and approvals apply to the modules specified in this document. In some cases, certain modules or applications may not be listed by certain approval agencies, or listing may be in process. *Consult factory for latest listing status.*

- **UL Listed:** S1196.
- **ULC Listed:** S6959 (TC806B1076CDN, TC806DNRCND).
- **MEA Listed:** 214-02-E.
- **FM Approved.**
- **CSFM:** 7272-1130:0144.

Product Line Information

NOTE: "A" or CDN suffix indicates ULC Listed model.

TC806B1076: Low-profile intelligent photoelectric sensor. Must be mounted to one of the bases listed below.

TC806B1076CDN: Same as TC806B1076 but with ULC listing.

TC806B1084: Same as TC806B1076 but includes a built-in 135°F (57°C) fixed-temperature thermal device.

TC806DNR: Low-profile intelligent photoelectric sensor, remote test capable. For use with DNRA/DNRW.

TC806DNRCND: Same as TC806DNR but with ULC listing. For use with DNRA.

INTELLIGENT BASES

NOTE: "A" or CDN suffix indicates ULC Listed model.

NOTE: For details on intelligent bases, see 85-3043.

B210LP(A): Standard U.S. flanged low-profile mounting base.

B210LPBP: Bulk pack of B210LP; package contains 10.

B501(A): Standard European flangeless mounting base.

B501BP: Bulk pack of B501; package contains 10.

B200S(A): Intelligent, programmable sounder base capable of producing sound output in high or low volume with ANSI Temporal 3, ANSI Temporal 4, continuous tone, marching tone, and custom tone.

B200SR(A): Intelligent sounder base capable of producing sound output with ANSI Temporal 3 or continuous tone. Replaces B501BH series bases in retrofit applications.

B224RB(A): Plug-in System Sensor **relay** base. Screw terminals: up to 14 AWG (2.0 mm²). Relay type: Form-C. Rating: 2.0 A @ 30 VDC resistive; 0.3 A @ 110 VDC inductive; 1.0 A @ 30 VDC inductive.

B224BI(A): Plug-in System Sensor **isolator** detector base. Maximum 25 devices between isolator bases. Replaces 14507371-005(CDN).

ACCESSORIES

F110: Retrofit flange to convert B210LP(A) to match the 14507371-001(CDN) profile, or to convert older high-profile bases to low-profile.

F110BP: Bulk pack of F110; package contains 15.

F210: Replacement flange for B210LP(A) base.

RA100Z(A): Remote LED annunciator. 3 – 32 VDC. Mounts to a U.S. single-gang electrical box. For use with B501(A) and B210LP(A) bases only.

SMB600: Surface mounting kit

M02-04-00: Test magnet.

M02-09-00: Test magnet with telescoping handle.

XR2B: Detector removal tool. Allows installation and/or removal of detector heads from bases in high ceiling applications.

XP-4: Extension pole for XR2B. Comes in three 5-foot (1.524 m) sections.

T55-127-010: Detector removal tool without pole.

BCK-200B: Black detector covers for use with TC806B1076(CDN) only; box of 10.

WCK-200B: White detector covers for use with TC806B1076(CDN) only; box of 10.

This document is not intended to be used for installation purposes. We try to keep our product information up-to-date and accurate. We cannot cover all specific applications or anticipate all requirements. All specifications are subject to change without notice.

FlashScan® is a registered trademark of Honeywell International Inc.

©2012 by Honeywell International Inc. All rights reserved. Unauthorized use of this document is strictly prohibited.

Automation and Control Solutions

Honeywell International Inc.
1985 Douglas Drive North
Golden Valley, MN 55422
www.honeywell.com

Honeywell Limited-Honeywell Limitée
35 Dynamic Drive
Scarborough, Ontario M1V 4Z9

74-1941-5 Rev. 01-12
January 2012
Made in the U.S.A.
© U.S. Registered Trademark
© 2012 Honeywell International Inc.
Page 2 of 2



74-1941-5

Honeywell

TC808B1041(CDN), TC808B1058(CDN), TC808B1066(CDN)

Intelligent Thermal (Heat) Detectors with FlashScan®

General

Honeywell TC808B(CDN) Series intelligent plug-in thermal detectors with integral communication has features that surpass conventional detectors. Point ID capability allows each detector's address to be set with rotary, decimal address switches, providing exact detector locations. TC808B(CDN) Series thermal detectors use an innovative thermistor sensing circuit to produce 135°F/57°C fixed-temperature (TC808B1041/CDN) and rate-of-rise thermal detection (TC808B1058/CDN) in a low-profile package. TC808B1066(CDN) provides fixed high-temperature detection at 190°F/88°C. These thermal detectors provide effective, intelligent property protection in a variety of applications. TC808(CDN) Series detectors are compatible with Honeywell XLS series Fire Alarm Control Panels (FACPs) in CLIP or FlashScan® mode.

FlashScan® (U.S. Patent 5,539,389) is a communication protocol that greatly enhances the speed of communication between analog intelligent devices. Intelligent devices communicate in a grouped fashion. If one of the devices within the group has new information, the panel's CPU stops the group poll and concentrates on single points. The net effect is response speed greater than five times that of earlier designs.

Features

- Sleek, low-profile, stylish design.
- State-of-the-art thermistor technology for fast response.
- Rate-of-rise model (TC808B1058/CDN), 15°F (8.3°C) per minute.
- Factory preset fixed temperature at 135°F (57°C); high-temperature model fixed at 190°F (88°C).
- Addressable by device.
- Compatible with FlashScan® and CLIP protocol systems.
- Rotary, decimal addressing (1-99 on CLIP systems, 1-159 on FlashScan systems).
- Two-wire SLC connection.
- Visible LEDs "blink" every time the unit is addressed.
- 360°-field viewing angle of the visual alarm indicators (two bi-color LEDs). LEDs blink green in Normal condition and turn on steady red in Alarm.
- Integral communications and built-in device-type identification.
- Remote test feature from the panel.
- Built-in functional test switch activated by external magnet.
- Walk test with address display (an address of 121 will blink the detector LED 12-(pause)-1).
- Low standby current.
- Backward-compatible.
- Built-in tamper-resistant feature.
- Designed for direct-surface or electrical-box mounting.
- Sealed against back pressure.
- Plugs into separate base for ease of installation and maintenance. Separate base allows interchange of photoelectric, ionization and thermal sensors.



TC808B1041 in B210LP(A) Base

- SEMS screws for wiring of the separate base.
- Constructed of off-white fire-resistant plastic, designed to commercial standards, and offers an attractive appearance.
- 94-5V plastic flammability rating.
- Remote LED output connection to optional RA100Z(A) remote LED annunciator.
- Optional sounder, relay, and isolator bases.
- Optional flanged surface mounting kit.

Specifications

Size: 2.1" (5.3 cm) high; base determines diameter.

- **B210LP(A):** 6.1" (15.5 cm) diameter.
- **B501(A):** 4.1" (10.4 cm) diameter.
- **B200S(A):** 6.875" (17.46 cm) diameter.
- **B200SR(A):** 6.875" (17.46 cm) diameter.
- **B224RB(A):** 6.2" (15.748 cm) diameter.
- **B224BI(A):** 6.2" (15.748 cm) diameter.

Shipping weight: 4.8 oz. (137 g).

Operating temperature range: TC808B1041(CDN), TC808B1058(CDN), TC808B1066(CDN), TC808B1058(CDN): -20°C to 38°C (-4°F to 100°F); TC808B1066(CDN): -20°C to 66°C (-4°F to 150°F).

Detector spacing: UL approved for 50 ft. (15.24 m) center to center. FM approved for 25 x 25 ft. (7.62 x 7.62 m) spacing.

Relative humidity: 10% – 93% noncondensing.

Thermal ratings: fixed-temperature setpoint 135°F (57°C), rate-of-rise detection 15°F (8.3°C) per minute, high temperature heat 190°F (88°C).

ELECTRICAL SPECIFICATIONS

Voltage range: 15 - 32 volts DC peak.

Standby current (max. avg.): 300 µA @ 24 VDC (one communication every 5 seconds with LED enabled).

LED current (max.): 6.5 mA @ 24 VDC ("ON").

Applications

Use thermal detectors for protection of property. For further information, go to systemsensor.com for manual I56-407-00, Applications Manual for System Smoke Detectors, which provides detailed information on detector spacing, placement, zoning, wiring, and special applications.

Installation

The TC808B Series plug-in intelligent thermal detectors use a separate base to simplify installation, service, and maintenance. Installation instructions are shipped with each detector. A special tool allows maintenance personnel to plug in and remove detectors without using a ladder

Mount base (all base types) on an electrical backbox which is at least 1.5" (3.81 cm) deep. For a chart of compatible junction boxes, see 85-3043.

NOTE: 1) Because of the inherent supervision provided by the SLC loop, end-of-line resistors are not required. Wiring "T-taps" or branches are permitted for Style 4 (Class "B") wiring. **2)** When using relay or sounder bases, consult the TC811A1006(CDN) installation sheet I56-1385 for device limitations between isolator modules and isolator bases.

Agency Listings and Approvals

These listings and approvals apply to the modules specified in this document. In some cases, certain modules or applications may not be listed by certain approval agencies, or listing may be in process. Consult factory for latest listing status.

- **UL Listed:** S1196.
- **ULC Listed:** S6972.
- **FM Approved.**
- **CSFM:** 7272-1130:0206 [TC808B1041(CDN) and TC808B1066(CDN) only].

Product Line Information

NOTE: "A" or "CDN" suffix indicates ULC Listed model.

TC808B1041: Intelligent thermal detector fixed 135°F. Must be mounted to one of the bases listed below.

TC808B1041CDN: Same as TC808B1041 but with ULC Listing.

TC808B1058: Intelligent thermal detector with rate-of-rise feature.

TC808B1058CDN: Same as TC808B1058 but with ULC Listing.

TC808B1066: Intelligent high-temperature 194°F thermal detector.

TC808B1066CDN: Same as TC808B1066 but with ULC Listing.

INTELLIGENT BASES

NOTE: "A" or "CDN" suffix indicates ULC Listed model.

NOTE: For details about intelligent bases and their mounting, see 85-3043.

B210LP(A): Standard U.S. flanged low-profile mounting base.

B210LPBP: Bulk pack of B210LP; package contains 10.

B501(A): Standard European flangeless mounting base.

B501BP: Bulk pack of B501; package contains 10.

B200S(A): Addressable Intelligent, programmable sounder base capable of producing sound output in high or low volume with ANSI Temporal 3, ANSI Temporal 4, continuous tone, marching tone, and custom tone.

B200SR(A): Intelligent sounder base capable of producing sound output with ANSI Temporal 3 or continuous tone. Replaces B501BH series bases in retrofit applications.

B224RB(A): Intelligent relay base. Screw terminals: up to 14 AWG (2.0 mm²). Relay type: Form-C. Rating: 2.0 A @ 30 VDC resistive; 0.3 A @ 110 VDC inductive; 1.0 A @ 30 VDC inductive.

B224BI(A): Intelligent isolator base. Isolates SLC from loop shorts. Maximum: 25 devices between isolator bases; see Note 2 under Installation. Replaces 14507371-005(CDN).

ACCESSORIES

F110: Retrofit flange to convert B210LP(A) to match the 14507371-001(CDN) profile, or to convert older high-profile bases to low-profile.

F110BP: Bulk pack of F110; package contains 15.

F210: Replacement flange for B210LP(A) base.

RA100Z(A): Remote LED annunciator. 3 – 32 VDC. Fits U.S. single-gang electrical box. Supported by B210LP(A) and B501(A) bases only.

SMB600: Surface mounting kit, flanged.

M02-04-00: Test magnet.

M02-09-00: Test magnet with telescoping handle.

XR2B: Detector removal tool. Allows installation and/or removal of FlashScan® Series detector heads from base in high ceiling installations. Includes T55-127-010.

T55-127-010: Detector removal tool without pole.

XP-4: Extension pole for XR2B. Comes in three 5-foot (1.524 m) sections.

This document is not intended to be used for installation purposes. We try to keep our product information up-to-date and accurate. We cannot cover all specific applications or anticipate all requirements. All specifications are subject to change without notice. FlashScan® is a registered trademark of Honeywell International Inc. ©2011 by Honeywell International Inc. All rights reserved. Unauthorized use of this document is strictly prohibited.

Automation and Control Solutions

Honeywell International Inc.
1985 Douglas Drive North
Golden Valley, MN 55422
www.honeywell.com

Honeywell Limited-Honeywell Limitée
35 Dynamic Drive
Scarborough, Ontario M1V 4Z9

74-3354-3 Rev. 12-11
December 2011
Made in the U.S.A.
© U.S. Registered Trademark
© 2011 Honeywell International Inc.
Page 2 of 2



74-3354-3

Honeywell

TC809A, TC809B, TC841A, TC809D

Monitor Modules with FlashScan®

General

Four different monitor modules are available for Honeywell's intelligent control panels for a variety of applications. Monitor modules supervise a circuit of dry-contact input devices, such as conventional heat detectors and pull stations, or monitor and power a circuit of two-wire smoke detectors (TC841A).

TC809A is a standard-sized module (typically mounts to a 4" [10.16 cm] square box) that supervises either a Style D (Class A) or Style B (Class B) circuit of dry-contact input devices.

TC809B is a miniature monitor module a mere 1.3" (3.302 cm) H x 2.75" (6.985 cm) W x 0.5" (1.270 cm) D that supervises a Style B (Class B) circuit of dry-contact input devices. Its compact design allows the TC809B1008(CDN) to be mounted in a single-gang box behind the device it monitors.

TC841A is a standard-sized module that monitors and supervises compatible two-wire, 24 volt, smoke detectors on a Style D (Class A) or Style B (Class B) circuit.

TC809D is a standard-sized dual monitor module that monitors and supervises two independent two-wire Style B (Class B) dry-contact initiating device circuits (IDCs) at two separate, consecutive addresses in intelligent, two-wire systems.

FlashScan® (U.S. Patent 5,539,389) is a communication protocol that greatly increases the speed of communication between analog intelligent devices. Intelligent devices communicate in a grouped fashion. If one of the devices within the group has new information, the panel CPU stops the group poll and concentrates on single points. The net effect is response speed greater than five times that of other design protocols.

TC809A Monitor Module

- Built-in type identification automatically identifies this device as a monitor module to the control panel.
- Powered directly by two-wire SLC loop. No additional power required.
- High noise (EMF/RFI) immunity.
- SEMS screws with clamping plates for ease of wiring.
- Direct-dial entry of address: 01 – 159 on FlashScan loops; 01 – 99 on CLIP loops.
- LED flashes green during normal operation (this is a programmable option) and latches on steady red to indicate alarm.

The TC809A Monitor Module is intended for use in intelligent, two-wire systems, where the individual address of each module is selected using the built-in rotary switches. It provides either a two-wire or four-wire fault-tolerant Initiating Device Circuit (IDC) for normally-open-contact fire alarm and supervisory devices. The module has a panel-controlled LED indicator.

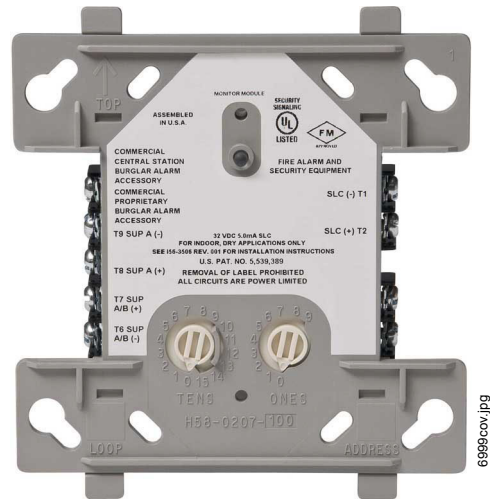

TC809A1059 (Type H)

TC809A APPLICATIONS

Use to monitor a zone of four-wire smoke detectors, manual fire alarm pull stations, waterflow devices, or other normally-open dry-contact alarm activation devices. May also be used to monitor normally-open supervisory devices with special supervisory indication at the control panel. Monitored circuit may be wired as an NFPA Style B (Class B) or Style D (Class A) Initiating Device Circuit. A 47K ohm End-of-Line Resistor (provided) terminates the Style B circuit. No resistor is required for supervision of the Style D circuit.

TC809A OPERATION

Each TC809A uses one of the available module addresses on an SLC loop. It responds to regular polls from the control panel and reports its type and the status (open/normal/short) of its Initiating Device Circuit (IDC). A flashing LED indicates that the module is in communication with the control panel. The LED latches steady on alarm (subject to current limitations on the loop).

TC809A SPECIFICATIONS

Nominal operating voltage: 15 to 32 VDC.

Maximum current draw: 5.0 mA (LED on).

Average operating current: 350 μ A (LED flashing), 1 communication every 5 seconds, 47k EOL.

Maximum IDC wiring resistance: 40 ohms.

EOL resistance: 47K ohms.

Temperature range: 32°F to 120°F (0°C to 49°C).

Humidity range: 10% to 93% noncondensing.

Dimensions: 4.5" (11.43 cm) high x 4" (10.16 cm) wide x 1.25" (3.175 cm) deep. Mounts to a 4" (10.16 cm) square x 2.125" (5.398 cm) deep box.

TC809B Mini Monitor Module

- Built-in type identification automatically identifies this device as a monitor module to the panel.
- Powered directly by two-wire SLC loop. No additional power required.
- High noise (EMF/RFI) immunity.
- Tinned, stripped leads for ease of wiring.
- Direct-dial entry of address: 01 – 159 on FlashScan loops; 01 – 99 on CLIP loops.

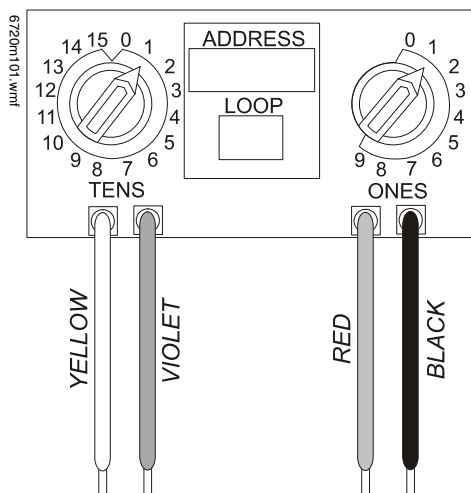

The TC809B Mini Monitor Module can be installed in a single-gang junction directly behind the monitored unit. Its small size and light weight allow it to be installed without rigid mounting. The TC809B is intended for use in intelligent, two-wire systems where the individual address of each module is selected using rotary switches. It provides a two-wire initiating device circuit for normally-open-contact fire alarm and security devices.

TC809B APPLICATIONS

Use to monitor a single device or a zone of four-wire smoke detectors, manual fire alarm pull stations, waterflow devices, or other normally-open dry-contact devices. May also be used to monitor normally-open supervisory devices with special supervisory indication at the control panel. Monitored circuit/device is wired as an NFPA Style B (Class B) Initiating Device Circuit. A 47K ohm End-of-Line Resistor (provided) terminates the circuit.

TC809B OPERATION

Each TC809B uses one of the available module addresses on an SLC loop. It responds to regular polls from the control panel and reports its type and the status (open/normal/short) of its Initiating Device Circuit (IDC).

TC809B SPECIFICATIONS

Nominal operating voltage: 15 to 32 VDC.

Average operating current: 350 μ A, 1 communication every 5 seconds, 47k EOL; 600 μ A Max. (Communicating, IDC Shorted).

Maximum IDC wiring resistance: 40 ohms.

Maximum IDC Voltage: 11 Volts.

Maximum IDC Current: 400 μ A.

EOL resistance: 47K ohms.

Temperature range: 32°F to 120°F (0°C to 49°C).

Humidity range: 10% to 93% noncondensing.

Dimensions: 1.3" (3.302 cm) high x 2.75" (6.985 cm) wide x 0.65" (1.651 cm) deep.

Wire length: 6" (15.24 cm) minimum.

TC841A Interface Module

- Supports compatible two-wire smoke detectors.
- Supervises IDC wiring and connection of external power source.
- High noise (EMF/RFI) immunity.
- SEMS screws with clamping plates for ease of wiring.
- Direct-dial entry of address: 01 – 159 on FlashScan loops, 01 – 99 on CLIP loops.
- LED flashes during normal operation; this is a programmable option.
- LED latches steady to indicate alarm on command from control panel.

The TC841A Interface Module is intended for use in intelligent, addressable systems, where the individual address of each module is selected using built-in rotary switches. This module allows intelligent panels to interface and monitor two-wire conventional smoke detectors. It transmits the status (normal, open, or alarm) of one full zone of conventional detectors back to the control panel. All two-wire detectors being monitored must be UL compatible with the module.

TC841A APPLICATIONS

Use the TC841A to monitor a zone of two-wire smoke detectors. The monitored circuit may be wired as an NFPA Style B (Class B) or Style D (Class A) Initiating Device Circuit. A 3.9 K ohm End-of-Line Resistor (provided) terminates the end of the Style B or D (class B or A) circuit (maximum IDC loop resistance is 25 ohms). Install ELR across terminals 8 and 9 for Style D application.

TC841A OPERATION

Each TC841A uses one of the available module addresses on an SLC loop. It responds to regular polls from the control panel and reports its type and the status (open/normal/short) of its Initiating Device Circuit (IDC). A flashing LED indicates that the module is in communication with the control panel. The LED latches steady on alarm (subject to current limitations on the loop).

TC841A SPECIFICATIONS

Nominal operating voltage: 15 to 32 VDC.

Maximum current draw: 5.1 mA (LED on).

Maximum IDC wiring resistance: 25 ohms.

Average operating current: 300 μ A, 1 communication and 1 LED flash every 5 seconds, 3.9k eol.

EOL resistance: 3.9K ohms.

External supply voltage (between Terminals T3 and T4): DC voltage: 24 volts power limited. Ripple voltage: 0.1 Vrms maximum. Current: 90 mA per module maximum.

Temperature range: 32°F to 120°F (0°C to 49°C).

Humidity range: 10% to 93% noncondensing.

Dimensions: 4.5" (11.43 cm) high x 4" (10.16 cm) wide x 1.25" (3.175 cm) deep. Mounts to a 4" (10.16 cm) square x 2.125" (5.398 cm) deep box.

TC809D Dual Monitor Module

The TC809D Dual Monitor Module is intended for use in intelligent, two-wire systems. It provides two independent two-wire initiating device circuits (IDCs) at two separate, consecutive addresses. It is capable of monitoring normally open contact fire alarm and supervisory devices; or either normally open or normally closed security devices. The module has a single panel-controlled LED.

NOTE: The TC809D provides two Style B (Class B) IDC circuits ONLY. Style D (Class A) IDC circuits are NOT supported in any application.

TC809D SPECIFICATIONS

Normal operating voltage range: 15 to 32 VDC.

Maximum current draw: 6.4 mA (LED on).

Average operating current: 750 μ A (LED flashing).

Maximum IDC wiring resistance: 1,500 ohms.

Maximum IDC Voltage: 11 Volts.

Maximum IDC Current: 240 μ A

EOL resistance: 47K ohms.

Maximum SLC Wiring resistance: 40 Ohms.

Temperature range: 32° to 120°F (0° to 49°C).

Humidity range: 10% to 93% (non-condensing).

Dimensions: 4.5" (11.43 cm) high x 4" (10.16 cm) wide x 2.125" (5.398 cm) deep.

TC809D AUTOMATIC ADDRESSING

The TC809D automatically assigns itself to two addressable points, starting with the original address. For example, if the TC809D is set to address "26", then it will automatically assign itself to addresses "26" and "27".

NOTE: "Ones" addresses on the TC809D are 0, 2, 4, 6, or 8 only. Terminals 6 and 7 use the first address, and terminals 8 and 9 use the second address.



CAUTION:

Avoid duplicating addresses on the system.

Installation

TC809A, TC841A, and TC809D modules mount directly to a standard 4" (10.16 cm) square, 2.125" (5.398 cm) deep, elec-

trical box. They may also be mounted to the SMB500 surface-mount box. Mounting hardware and installation instructions are provided with each module. All wiring must conform to applicable local codes, ordinances, and regulations. These modules are intended for power-limited wiring only.

The TC809B module is intended to be wired and mounted without rigid connections inside a standard electrical box. All wiring must conform to applicable local codes, ordinances, and regulations.

Agency Listings and Approvals

In some cases, certain modules may not be listed by certain approval agencies, or listing may be in process. Consult factory for latest listing status.

- **UL:** S470
- **ULC:** S7567
- **FM Approved**
- **CSFM:** 7300-1130:0115, 7300-1130:0218, 7165-1130:0256 (XLS3000)
- **MEA:** 457-99-E Vol. 4 (does not apply for TC809D1004)
- **FDNY:** COA #6060

Product Line Information

NOTE: "CDN" suffix indicates ULC-listed model.

TC809A1059: Monitor module.

TC809A1067CDN: Monitor module, ULC.

TC809B1008: Monitor module, miniature.

TC809B1016CDN: Monitor module, miniature, ULC.

TC841A1000: Monitor module, two-wire detectors.

TC841A1000CDN: Monitor module, dual, two-wire detectors, ULC.

TC809D1004: Monitor module, dual, two independent Class B circuits.

TC809D1004CDN: Monitor module, dual, two independent Class B circuits, ULC.

SMB500: Optional surface-mount backbox.

NOTE: See installation instructions and refer to the SLC Wiring Manual, PN 95-7675 (51932).

This document is not intended to be used for installation purposes. We try to keep our product information up-to-date and accurate. We cannot cover all specific applications or anticipate all requirements. All specifications are subject to change without notice. FlashScan® is a registered trademark and FireWatch™ is a trademark of Honeywell International Inc. ©2010 by Honeywell International Inc. All rights reserved. Unauthorized use of this document is strictly prohibited.

Automation and Control Solutions

Honeywell International Inc.
1985 Douglas Drive North
Golden Valley, MN 55422
www.honeywell.com

Honeywell Limited-Honeywell Limitée
35 Dynamic Drive
Scarborough, Ontario M1V 4Z9

74-3993-4 Rev. 10-10
October 2010
Made in the U.S.A.
© U.S. Registered Trademark
© 2010 Honeywell International Inc.
Page 4 of 4



74-3993-4

Honeywell

TC810N1013(CDN), TC810R1024(CDN)

Control and Relay Modules with FlashScan®

General

TC810N1013(CDN) Control Module: The TC810N1013(CDN) Addressable Control Module provides Honeywell intelligent fire alarm control panels a circuit for Notification Appliances (horns, strobes, speakers, etc.). Addressability allows the TC810N1013(CDN) to be activated, either manually or through panel programming, on a select (zone or area of coverage) basis.

TC810R1024(CDN) Relay Module: The TC810R1024(CDN) Addressable Relay Module provides the system with a dry-contact output for activating a variety of auxiliary devices, such as fans, dampers, control equipment, etc. Addressability allows the dry contact to be activated, either manually or through panel programming, on a select basis.

FlashScan® (U.S. Patent 5,539,389) is a communication protocol that greatly enhances the speed of communication between analog intelligent devices. Intelligent devices communicate in a grouped fashion. If one of the devices within the group has new information, the panel CPU stops the group poll and concentrates on single points. The net effect is response speed greater than five times that of other designs.

Features

- Built-in type identification automatically identifies these devices to the control panel.
- Internal circuitry and relay powered directly by two-wire SLC loop. The TC810N1013(CDN) module requires power (for horns, strobes, etc.), or audio (for speakers).
- Integral LED “blinks” green each time a communication is received from the control panel and turns on in steady red when activated.
- LED blink may be deselected globally (affects all devices).
- High noise immunity (EMF/RFI).
- The TC810N1013(CDN) may be used to switch 24-volt NAC power, audio (up to 70.7 Vrms).
- Wide viewing angle of LED.
- SEMS screws with clamping plates for wiring ease.
- Direct-dial entry of address 01– 159 for FlashScan loops, 01 – 99 for CLIP mode loops.
- Speaker, and audible/visual applications may be wired for Class B or A (Style Y or Z).

Applications

The TC810N1013(CDN) is used to switch 24 VDC audible/visual power, high-level audio (speakers). The TC810R1024(CDN) may be programmed to operate dry contacts for applications such as door holders or Air Handling Unit shutdown, and to reset four-wire smoke detector power.

NOTE: Refer to the SLC Manual (PN 95-7675 (51932)) for details regarding releasing applications with the TC810N1013(CDN).

Construction

- The face plate is made of off-white heat-resistant plastic.
- Controls include two rotary switches for direct-dial entry of address (01-159).

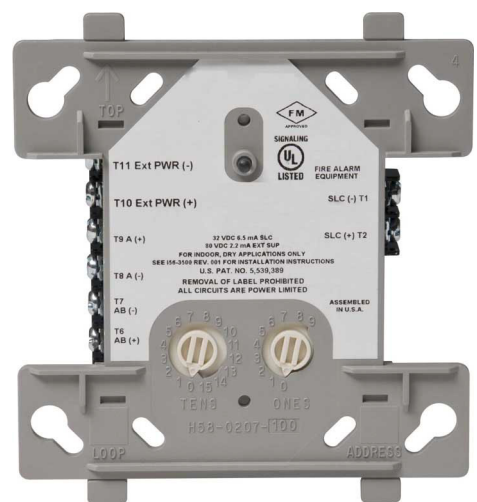

TC810N1013

- The TC810N1013(CDN) is configured for a single Class B (Style Y) or Class A (Style Z) Notification Appliance Circuit.
- The TC810R1024(CDN) provides two Form-C dry contacts that switch together.

Operation

Each TC810N1013(CDN) or TC810R1024(CDN) uses one of 159 possible module addresses on a SLC loop (99 on CLIP loops). It responds to regular polls from the control panel and reports its type and status, including the open/normal/short status of its Notification Appliance Circuit (NAC). The LED blinks with each poll received. On command, it activates its internal relay. The TC810N1013(CDN) supervises Class B (Style Y) or Class A (Style Z) notification or control circuits.

Upon code command from the panel, the TC810N1013(CDN) will disconnect the supervision and connect the external power supply in the proper polarity across the load device. The disconnection of the supervision provides a positive indication to the panel that the control relay actually turned ON. The external power supply is always relay isolated from the communication loop so that a trouble condition on the external power supply will never interfere with the rest of the system.

Rotary switches set a unique address for each module. The address may be set before or after mounting. The built-in TYPE CODE (not settable) will identify the module to the control panel, so as to differentiate between a module and a sensor address.

Specifications for TC810N1013(CDN)

Normal operating voltage: 15 to 32 VDC.

Maximum current draw: 6.5 mA (LED on).

Average operating current: 350 μ A direct poll, 375 μ A group poll with LED flashing, 485 μ A Max. (LED flashing, NAC shorted.)

Maximum NAC Line Loss: 4 VDC.

External supply voltage (between Terminals T10 and T11): Maximum (NAC): Regulated 24 VDC; Maximum (Speakers): 70.7 V RMS, 50W.

Drain on external supply: 1.7 mA maximum using 24 VDC supply; 2.2 mA Maximum using 80 VRMS supply.

Max NAC Current Ratings: For class B wiring system, the current rating is 3A; For class A wiring system, the current rating is 2A.

Temperature range: 32°F to 120°F (0°C to 49°C).

Humidity range: 10% to 93% non-condensing.

Dimensions: 4.5" (114.3 mm) high x 4" (101.6 mm) wide x 1.25" (31.75 mm) deep. Mounts to a 4" (101.6 mm) square x 2.125" (53.975 mm) deep box.

Accessories: SMB500 Electrical Box; CB500 Barrier

Specifications for TC810R1024(CDN)

Normal operating voltage: 15 to 32 VDC.

Maximum current draw: 6.5 mA (LED on).

Average operating current: 230 µA direct poll; 255 µA group poll.

EOL resistance: not used.

Temperature range: 32°F to 120°F (0°C to 49°C).

Humidity range: 10% to 93% non-condensing.

Dimensions: 4.5" (114.3 mm) high x 4" (101.6 mm) wide x 1.25" (31.75 mm) deep. Mounts to a 4" (101.6 mm) square x 2.125" (53.975 mm) deep box.

Accessories: SMB500 Electrical Box; CB500 Barrier

Agency Listings and Approvals

In some cases, certain modules may not be listed by certain approval agencies, or listing may be in process. Consult factory for latest listing status.

- **UL:** S470
- **ULC:** S7567 (CDN version only)
- **FM Approved**
- **CSFM:** 7300-1130:0218
- **MEA:** 2-02-E
- **FDNY:** COA #6060, #6076

Contact Ratings for TC810R1024(CDN)

Current Rating	Maximum Voltage	Load Description	Application
3 A	30 VDC	Resistive	Non-Coded
2 A	30 VDC	Resistive	Coded
.9 A	110 VDC	Resistive	Non-Coded
.9 A	125 VDC	Resistive	Non-Coded
.5 A	30 VDC	Inductive (L/R=5ms)	Coded
1 A	30 VDC	Inductive (L/R=2ms)	Coded
.3 A	125 VAC	Inductive (PF=0.35)	Non-Coded
1.5 A	25 VAC	Inductive (PF=0.35)	Non-Coded
.7 A	70.7 VAC	Inductive (PF=0.35)	Non-Coded
2 A	25 VAC	Inductive (PF=0.35)	Non-Coded

NOTE: Maximum (Speakers): 70.7 V RMS, 50 W

Product Line Information

NOTE: "CDN" suffix indicates ULC Listed model.

TC810N1013(CDN): Intelligent Addressable Control Module.

TC810R1024(CDN): Intelligent Addressable Relay Module.

A2143-20: Capacitor, required for Class A (Style Z) operation of speakers.

SMB500: Optional Surface-Mount Backbox.

CB500: Control Module Barrier — required by UL for separating power-limited and non-power limited wiring in the same junction box as TC810N1013(CDN).

NOTE: For installation instructions, see the following documents:

- TC810N1013(CDN) Installation document I56-3800.
- TC810R1024(CDN) Installation document I56-3802.
- Honeywell SLC Wiring Manual, document 95-7675 (51932).

This document is not intended to be used for installation purposes. We try to keep our product information up-to-date and accurate. We cannot cover all specific applications or anticipate all requirements. All specifications are subject to change without notice.

FlashScan® is a registered trademark of Honeywell International Inc.

©2011 by Honeywell International Inc. All rights reserved. Unauthorized use of this document is strictly prohibited.

Automation and Control Solutions

Honeywell International Inc.
1985 Douglas Drive North
Golden Valley, MN 55422
www.honeywell.com

Honeywell Limited-Honeywell Limitée
35 Dynamic Drive
Scarborough, Ontario M1V 4Z9

74-3995-4 Rev. 2-11
February 2011
Made in the U.S.A.
© U.S. Registered Trademark
© 2011 Honeywell International Inc.
Page 2 of 2



74-3995-4

Honeywell

XP6-R

Six Relay Control Module

General

The XP6-R six-relay control module provides an intelligent fire alarm system with six Form-C relays.

The first module is addressed from 01 to 154 while the remaining modules are automatically assigned to the next five higher addresses. Provisions are included for disabling a maximum of three unused modules. A single isolated set of dry relay contacts is provided for each module address, which is capable of being wired for either a normally-open or normally-closed operation. The module allows the control panel to switch these contacts on command. No supervision is provided for the controlled circuit.

Each XP6-R module has panel-controlled green LED indicators. The panel can cause the LEDs to blink, latch on, or latch off.

Features

- Six addressable Form-C relay contacts.
- Removable 12 AWG (3.25 mm²) to 18 AWG (0.9 mm²) plug-in terminal blocks.
- Status indicators for each point.
- Unused addresses may be disabled.
- Rotary address switches.
- FlashScan® or CLIP operation (NOTE: Not compatible with the XLS1000 or FS90 Plus).
- Mount one or two modules in a BB-XP cabinet (optional).
- Mount up to six modules on a CHS-6 chassis in a CAB-4 Series, EQ Series, or BB-25 cabinet (optional).
- Mounting hardware included.

Specifications

Standby current: 1.45 mA (SLC current draw with all addresses used; if some addresses are disabled, the standby current decreases).

Alarm current: 32 mA (assumes all six relays have been switched once and all six LEDs solid ON).

Temperature range: 32°F to 120°F (0°C to 49°C).

Humidity: 10% to 93% noncondensing.

Dimensions: 6.8" (172.72 mm) high x 5.8" (147.32 mm) wide x 1.0" (25.40 mm) deep.

Shipping weight: 1.1 lb. (0.499 kg) including packaging.

Mounting options: CHS-6 chassis, BB-25 cabinet, BB-XP cabinet, CAB-4 Series (see 85-3002) cabinet, or EQ Series (see 85-3110) cabinet.

Wire gauge: 12 AWG (3.25 mm²) to 18 AWG (0.9 mm²).

Maximum SLC wiring resistance: 40 or 50 ohms, panel dependent.

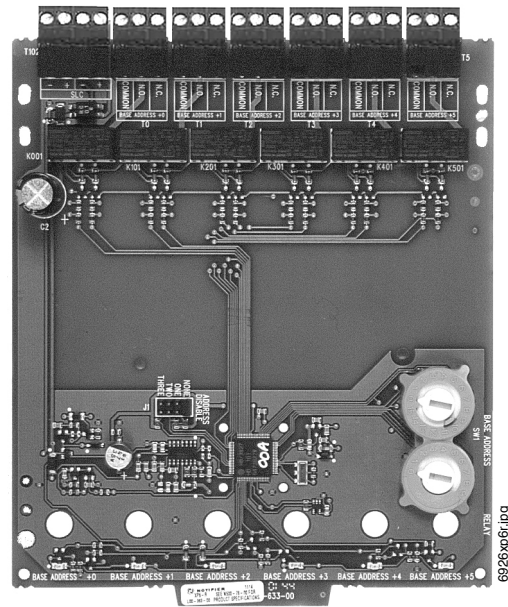

Relay current: 30 mA/relay pulse (15.6 ms pulse duration), pulse under panel control.

Relay contact ratings: 30 VDC; 70.7 VAC.

Current ratings:

- 3.0 A @ 30 VDC maximum, resistive, non-coded.
- 2.0 A @ 30 VDC maximum, resistive, coded.
- 1.0 A @ 30 VDC maximum, inductive (L/R = 2 ms), coded.
- 0.5 A @ 30 VDC maximum, inductive (L/R = 5 ms), coded.
- 0.9 A @ 110 VDC maximum, resistive, non-coded.
- 0.9 A @ 125 VAC maximum, resistive, non-coded.
- 0.7 A @ 70.7 VAC maximum, inductive (PF = 0.35), non-coded.
- 0.3 A @ 125 VAC maximum, inductive (PF = 0.35), non-coded.
- 1.5 A @ 25 VAC maximum, inductive (PF = 0.35), non-coded.
- 2.0 A @ 25 VAC maximum, inductive (PF = 0.35), non-coded.

Agency Listings and Approvals

These listings and approvals apply to the modules specified in this document. In some cases, certain modules or applications may not be listed by certain approval agencies, or listing may be in process. Consult factory for latest listing status.

- **UL Listed:** S635
- **ULC Listed:** S635 (XP6-RA)
- **MEA Listed:** 368-01-E
- **CSFM:** 7300-0028:219
- **Maryland State Fire Marshall:** Permit # 2099
- **FM Approved** (Light Protective Signaling Only)

Product Line Information

XP6-R: Six-relay control module.

XP6-RA: Same as above with ULC Listing.

BB-XP: Optional cabinet for one or two modules. Dimensions, DOOR: 9.234" (23.454 cm) wide (9.484" [24.089 cm] including hinges), x 12.218" (31.0337 cm) high, x 0.672" (1.7068 cm) deep; BACKBOX: 9.0" (22.860 cm) wide (9.25" [23.495 cm] including hinges), x 12.0" (30.480 cm) high x 2.75" (6.985 cm); CHASSIS (installed): 7.150" (18.161 cm) wide overall x 7.312"

(18.5725 cm) high interior overall x 2.156" (5.4762 cm) deep overall.

BB-25: Optional cabinet for up to six modules mounted on CHS-6 chassis (below). Dimensions, DOOR: 24.0" (60.96 cm) wide x 12.632" (32.0852 cm) high, x 1.25" (3.175 cm) deep, hinged at bottom; BACKBOX: 24.0" (60.96 cm) wide x 12.550" (31.877 cm) high x 5.218" (13.2537 cm) deep.

CHS-6: Chassis, mounts up to six modules in a CAB-4 Series (see 85-3002), BB-25, or EQ Series (see 85-3110) cabinet.

This document is not intended to be used for installation purposes. We try to keep our product information up-to-date and accurate. We cannot cover all specific applications or anticipate all requirements. All specifications are subject to change without notice.

FlashScan® is a registered trademark of Honeywell International Inc.

©2010 by Honeywell International Inc. All rights reserved. Unauthorized use of this document is strictly prohibited.

Automation and Control Solutions

Honeywell International Inc.
1985 Douglas Drive North
Golden Valley, MN 55422
www.honeywell.com

Honeywell Limited-Honeywell Limitée
35 Dynamic Drive
Scarborough, Ontario M1V 4Z9

HON-60159:A
85-3071 Rev. 2/10
February 2010
Made in the U.S.A.
© U.S. Registered Trademark
© 2010 Honeywell International Inc.
Page 2 of 2



85-3071-1

Honeywell

XP6-C

Six Circuit Supervised Control Module and SYNC-1 Accessory Card

General

The **XP6-C six-circuit supervised control module** provides intelligent alarm systems with supervised monitoring of wiring to load devices that require an external power supply to operate, such as horns, strobes, or bells. Each module is intended for switching applications involving AC DC or audio, which require wiring supervision. Upon command from the control panel, the XP6-C will disconnect the supervision and connect the external power supply across the load device.

The first module is addressed from 01 to 154 while the remaining modules are automatically assigned to the next five higher addresses. Each XP6-C module has terminals for connection to an external supply circuit for powering devices on its notification appliance circuit (NAC). One or multiple power supplies or amplifiers may be used.

NOTE: Provisions are included for disabling a maximum of three unused addresses.

Each XP6-C module features a short-circuit-protection monitor to protect the external power supply against short-circuit conditions on the NAC. When an alarm condition occurs, the relay which connects the external supply to the NAC will not be allowed to close if a short-circuit condition currently exists on the NAC. Additionally, an algorithm is incorporated to find shorts when the module is active. The XP6-C module will close all circuits that are not shorted to find the NAC with the problem.

Each XP6-C module has panel-controlled green LED indicators. The panel can cause the LEDs to blink, latch on, or latch off.

The **SYNC-1 accessory card** provides the XP6-C with additional functionality with compatible System Sensor SpectrAlert® and SpectrAlert Advance® audio/visual devices.

Features

- Six addressable Style B (Class B) or three addressable Style D (Class A) outputs that function as notification appliance/speaker/telephone circuits.
- Removable 12 AWG (3.31 mm²) to 18 AWG (0.821 mm²) plug-in terminal blocks.
- Status indicators for each point.
- Unused addresses may be disabled (up to 3).
- Rotary address switches.
- FlashScan® or CLIP operation.

NOTE: Not compatible with the FS90 Plus or XLS 1000.

- Optional SYNC-1 accessory card for SpectrAlert and SpectrAlert Advance devices.
- Mount one or two modules in a BB-XP cabinet (optional).
- Mount up to six modules on a CHS-6 chassis in a CAB-3 Series, CAB-4 Series, EQ Series, or BB-25 cabinet (optional).
- Mounting hardware included.

Specifications

Standby current: 2.25 mA (SLC current draw with all addresses used; if some addresses are disabled, the standby current decreases).

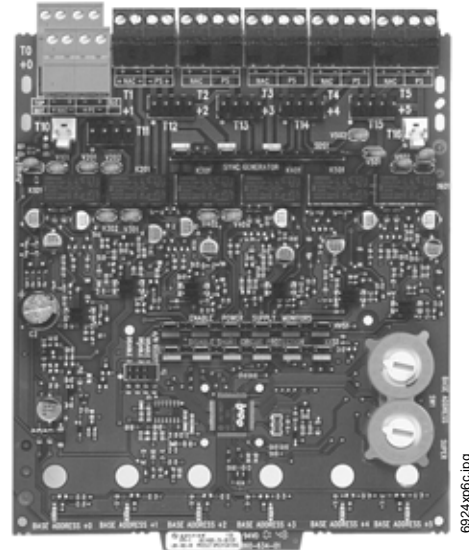

Alarm current: 35 mA (assumes all six NACS have been switched once and all six LEDs solid ON).

Temperature range: 32°F to 120°F (0°C to 49°C) for UL applications; -10°C to +55°C for EN54 applications.

Humidity: 10% to 85% noncondensing for UL applications; 10% to 93% noncondensing for EN54 applications.

Dimensions: 6.8" (172.72 mm) high x 5.8" (147.32 mm) wide x 1.25" (31.75 mm) deep.

Shipping weight: 1.1 lb. (0.499 kg) including packaging.

Mounting options: CHS-6 chassis, BB-25 cabinet, BB-XP cabinet, CAB-3/CAB-4 series backboxes and doors, or EQ Series cabinet.

Wire gauge: 12 AWG (3.31 mm²) to 18 AWG (0.821 mm²), grounded.

XP6-C is shipped in Class B position; remove shunt for Class A operation.

Maximum SLC wiring resistance: 40 or 50 ohms, panel dependent.

Maximum NAC wiring resistance: 40 ohms.

Power rating per circuit: 63 W @ 70.7 VAC (UL applications only); 22.5 W @ 25 VAC.

Current ratings:

- 3.0 A @ 30 VDC maximum, resistive, non-coded.
- 2.0 A @ 30 VDC maximum, resistive, coded.
- 1.0 A @ 30 VDC maximum, inductive (L/R = 2 ms), coded.
- 0.5 A @ 30 VDC maximum, inductive (L/R = 5 ms), coded.
- 0.9 A @ 70.7 VAC maximum (UL only), resistive, non-coded.
- 0.7 A @ 70.7 VAC maximum (UL only), inductive (PF = 0.35), non-coded.

Compatible devices: See the documentation for your panel, and the Honeywell Device Compatibility document. Contact Honeywell. See also list of devices compatible with SYNC-1 below.

SYNC-1 Accessory Card

The SYNC-1 accessory card is designed to operate with the XP6-C. It works with the SpectrAlert and the SpectrAlert Advance series of horns, strobes, and horn/strobes to provide a means of synchronizing the temporal-coded horns; synchronizing the one-second flash timing of the strobe; and silencing the horns of the horn/strobe combination over a two-wire circuit while leaving the strobes active. Each SYNC-1 accessory card is capable of synchronizing six Class B circuits or three Class A circuits.

Maximum load on a loop: 3 A.

Operating temperature: 32°F to 120°F (0°C to 49°C).

Wire size: 12 to 18 AWG (3.31 to 0.821 mm²).

Operating voltage range: 11 to 30 VDC FWR, filtered or unfiltered. Refer to notification appliance installation instructions for number of notification appliances and wire size.

Compatible A/V devices: The SYNC-1 Accessory Card is compatible with all System Sensor SpectrAlert and SpectrAlert Advance Audio Visual Devices that have synchronization capability. Other manufacturers may be supported as well. Please refer to the latest Device Compatibility Document, PN 51939.

NOTE: *SpectrAlert and SpectrAlert Advance products utilizing SYNC-1 module below.

Product Line Information

XP6-C: Six-circuit supervised control module.

XP6-CA: Same as above with ULC Listing.

SYNC-1: Optional accessory card for synchronization of compatible System Sensor SpectrAlert horns, strobes, and horn/strobes.

BB-XP: Optional cabinet for one or two modules. **Dimensions, DOOR:** 9.234" (23.454 cm) wide (9.484" [24.089 cm] including hinges), x 12.218" (31.0337 cm) high, x 0.672" (1.7068 cm) deep; **BACKBOX:** 9.0" (22.860 cm) wide (9.25" [23.495 cm] including hinges), x 12.0" (30.480 cm) high x 2.75" (6.985 cm); **CHASSIS (installed):** 7.150" (18.161 cm) wide overall x 7.312" (18.5725 cm) high interior overall x 2.156" (5.4762 cm) deep overall.

BB-25: Optional cabinet for up to six modules mounted on CHS-6 chassis (*below*). **Dimensions, DOOR:** 24.0" (60.96 cm) wide x 12.632" (32.0852 cm) high, x 1.25" (3.175 cm) deep, hinged at bottom; **BACKBOX:** 24.0" (60.96 cm) wide x 12.550" (31.877 cm) high x 5.218" (13.2537 cm) deep.

CHS-6: Chassis, mounts up to six modules in a CAB-4 Series (see 85-3002) cabinet, or EQ Series cabinet.

Agency Listings and Approvals

These listings and approvals apply to the modules specified in this document. In some cases, certain modules or applications may not be listed by certain approval agencies, or listing may be in process. Consult factory for latest listing status.

- **UL Listed:** S3705 (S3705 SYNC-1)
- **ULC Listed:** S635/CS118 (XP6-CA)
- **MEA Listed:** 43-02-E / 226-03-E (SYNC-1)
- **FM Approved** (Local Protective Signaling) - XP6-C only
- **CSFM:** 7165-1130:234 7170-1130:235 7300-1653:100 (SYNC-1)
- **Maryland State Fire Marshal:** Permit # 2106 (XP6-C)

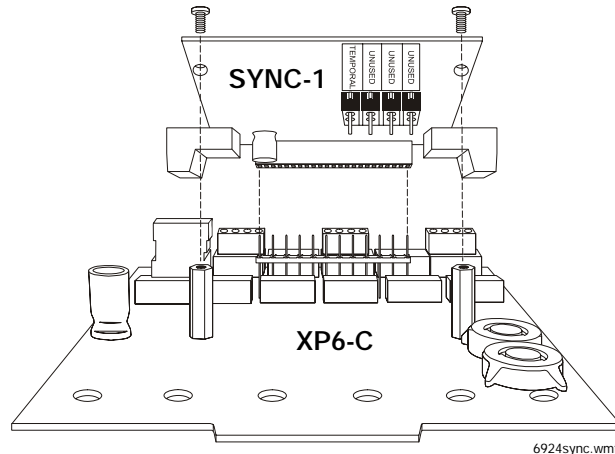

Module setup: Before installing the accessory card on the XP6-C module, add the shunt to the board where indicated if any horns are required to sound in temporal pattern.

Parts included with SYNC-1: Two shunts, four screws, and two standoffs. See installation instructions for details on mounting and wiring the accessory card and module.

Figure 1 Mounting the SYNC-1 accessory card to the XP6-C module

Wiring Diagrams

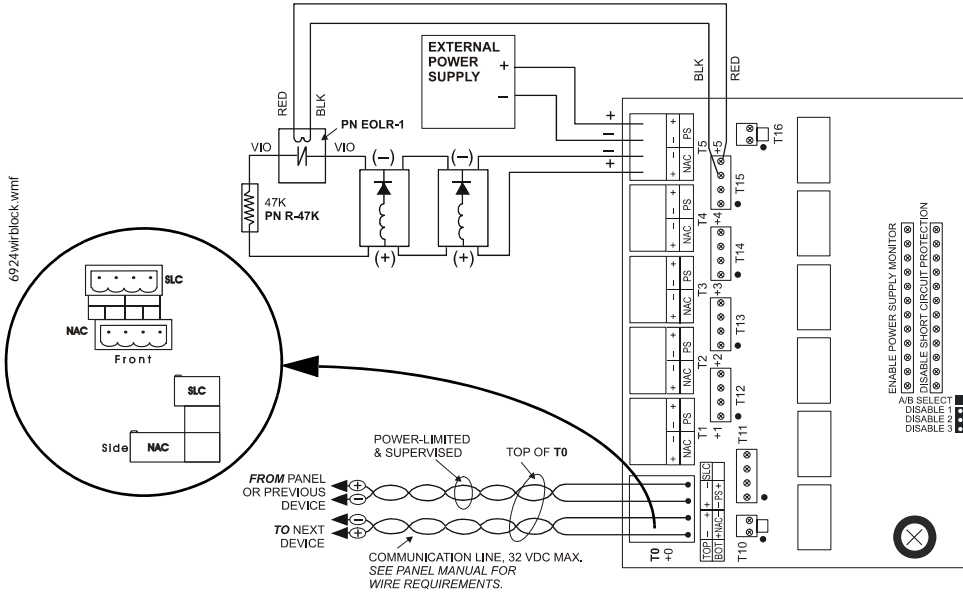

NOTE: If the FACP does not inherently monitor for loss of external power to the module, an external EOLR-1 Relay Module may be required on each NAC that has a dedicated supply. Refer to the Honeywell SLC manual for more information.

Figure 2 Example of Class B, Style Y NAC configuration with a single supply dedicated to a single NAC

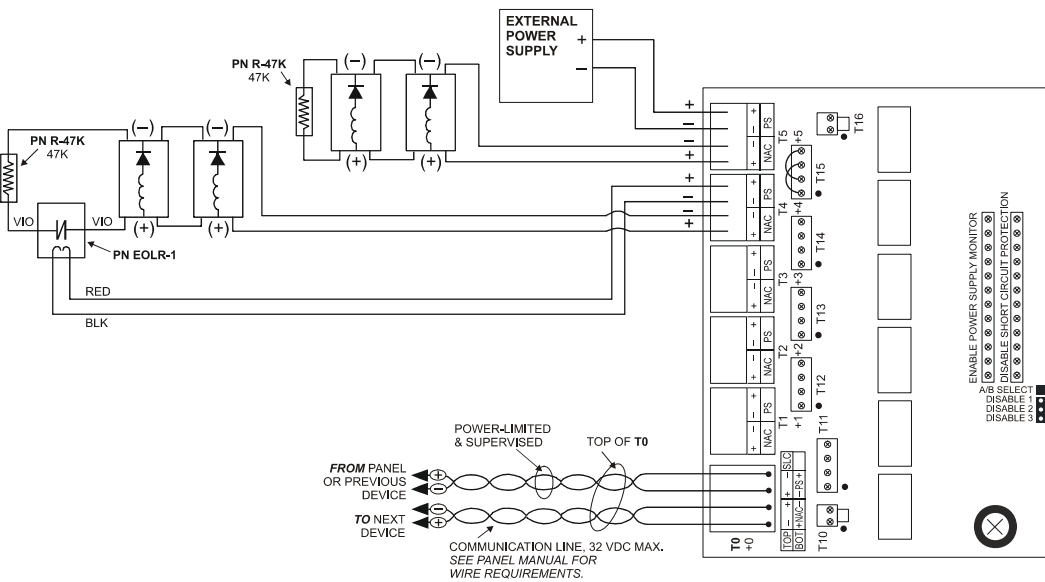
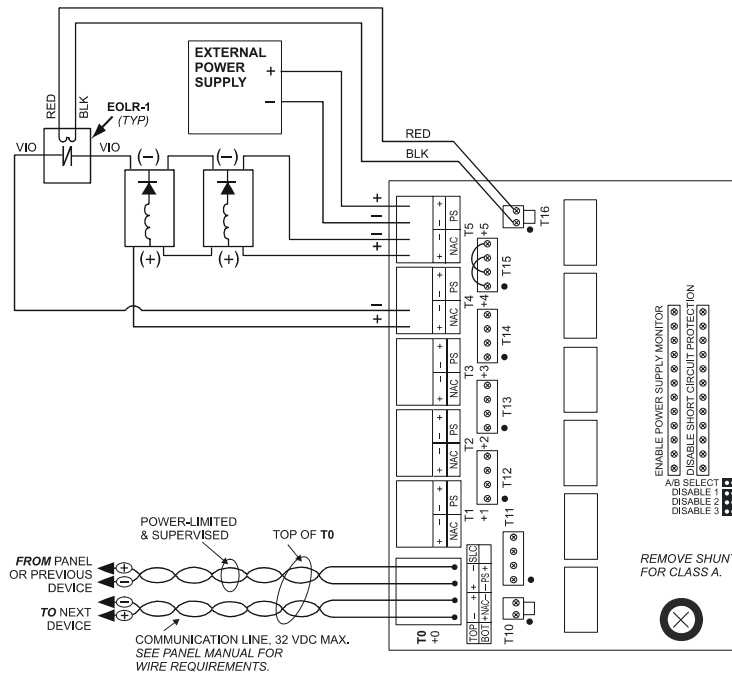
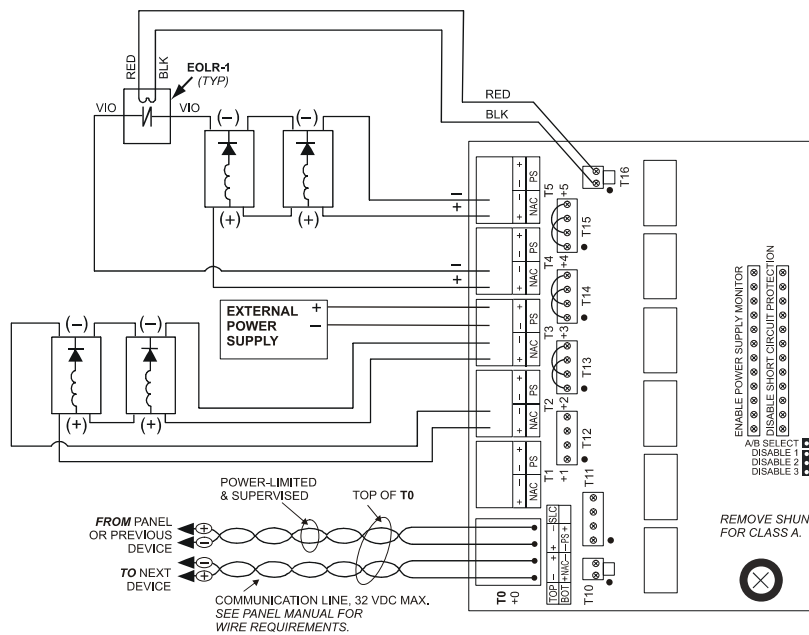

Figure 3 Example of Class B, Style Y NAC configuration with a single supply shared by two NACs



6924wlr3.wmf

Figure 4 Example of Class A, Style Z NAC configuration with a single supply dedicated to a single NAC



6924wlr4.wmf

Figure 5 Example of Class A, Style Z NAC configuration with a single supply shared by 2 NACs

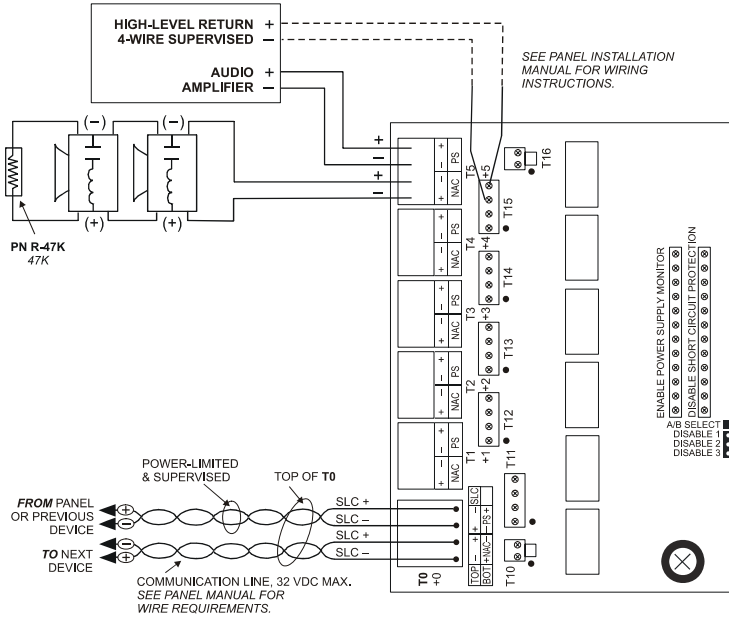

6924wlr5.wmf

Figure 6 Example of Class B, Style Y audio NAC configuration

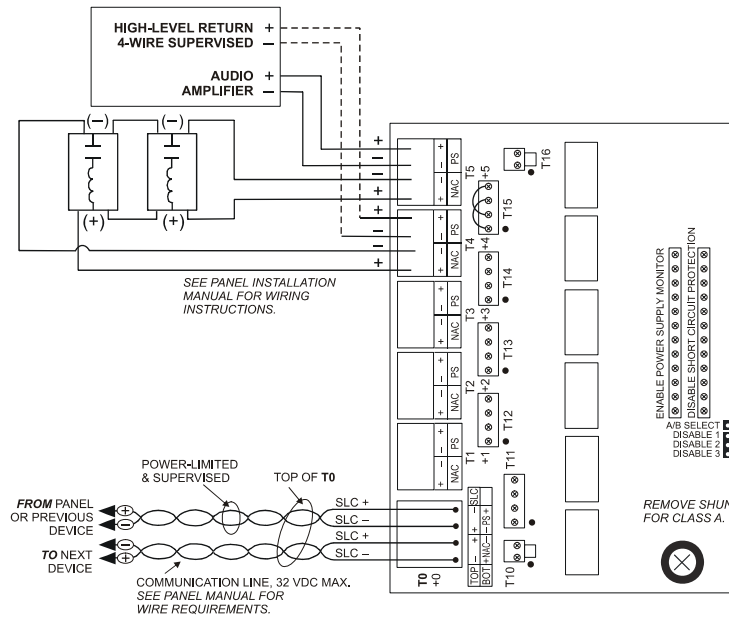

6924wlr6.wmf

Figure 7 Example of Class A, Style Z audio NAC configuration

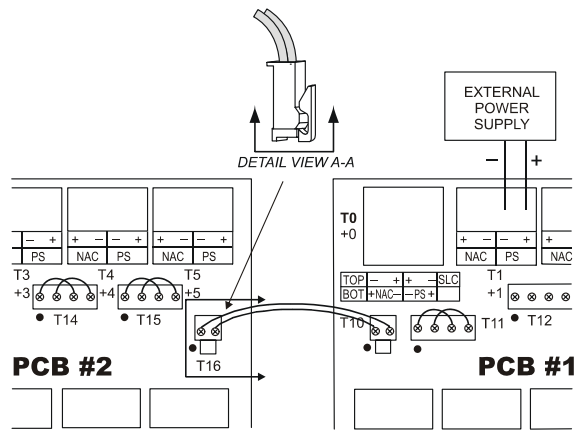

6924wlr7.wmf

NOTE: Supply is shared by NACs +0 and +1 (on PCB #1) as well as +3, +4, and +5 (on PCB #2). Refer to Figure 2 through Figure 5 for typical NAC wiring. Make certain that the lip on the long power supply jumper engages the retaining tab on T10 or T16 as shown in detail view A-A.

Figure 8 Example of multiple boards sharing the same external power supply

This document is not intended to be used for installation purposes. We try to keep our product information up-to-date and accurate. We cannot cover all specific applications or anticipate all requirements. All specifications are subject to change without notice.

FlashScan®, SpectrAlert®, SpectrAlert Advance®, and System Sensor® are registered trademarks of Honeywell International Inc. ©2007 by Honeywell International Inc. All rights reserved. Unauthorized use of this document is strictly prohibited.

Automation and Control Solutions

Honeywell International Inc.
 1985 Douglas Drive North
 Golden Valley, MN 55422
 www.honeywell.com

Honeywell Limited-Honeywell Limitée
 35 Dynamic Drive
 Scarborough, Ontario M1V 4Z9

85-3069 Rev. 08/07
 August 2007
 Made in the U.S.A.
 ® U.S. Registered Trademark
 © 2007 Honeywell International Inc.
 Page 6 of 6



S464G1007

Addressable Manual Pull Station

General

The S464G1007 is a state-of-the-art, dual-action (i.e., requires two motions to activate the station) pull station that includes an addressable interface for use with Honeywell's compatible Intelligent Fire Alarm Control Panels. Because the S464G1007 is addressable, the control panel can display the exact location of the activated manual station. This leads fire personnel quickly to the location of the alarm.

Features

- Maintenance personnel can open station for inspection and address setting without causing an alarm condition.
- Built-in bicolor LED, which is visible through the handle of the station, flashes in normal operation and latches steady red when in alarm.
- Handle latches in down position and the word "ACTIVATED" appears to clearly indicate the station has been operated.
- Captive screw terminals wire-ready for easy connection to SLC loop (accepts up to 12 AWG/3.25 mm² wire).
- Can be surface mounted (with SB-10 or SB-I/O) or semi-flush mounted. Semi-flush mount to a standard single-gang, double-gang, or 4" (10.16 cm) square electrical box.
- Smooth dual-action design.
- Meets ADAAG controls and operating mechanisms guidelines (Section 4.1.3[13]); meets ADA requirement for 5 lb. maximum activation force.
- Highly visible.
- Attractive shape and textured finish.
- Key reset.
- Includes Braille text on station handle.
- Optional trim ring (BG12TR).
- Meets UL 38, Standard for Manually Actuated Signaling Boxes.
- Up to 99 S464G1007 stations per loop on CLIP protocol loops.
- Up to 159 S464G1007 stations per loop on FlashScan® protocol loops.
- Dual-color LED blinks green to indicate normal on FlashScan® systems.

Construction

Shell, door, and handle are molded of durable polycarbonate material with a textured finish.

Specifications

- **Shipping Weight:** 9.6 oz. (272.15 g)
- **Normal operating voltage:** 24 VDC.
- **Maximum SLC loop voltage:** 28.0 VDC.
- **Maximum SLC standby current:** 375 µA.
- **Maximum SLC alarm current:** 5 mA.
- **Temperature Range:** 32°F to 120°F (0°C to 49°C)
- **Relative Humidity:** 10% to 93% (noncondensing)
- **For use indoors in a dry location (Note:** Use S464F1008WP for outdoor applications; see 85-3055.)



The S464G1007
Addressable Manual Pull Station

Installation

The S464G1007 will mount semi-flush into a single-gang, double-gang, or standard 4" (10.16 cm) square electrical outlet box, or will surface mount to the model SB-10 or SB-I/O surface backbox. If the S464G1007 is being semi-flush mounted, then the optional trim ring (BG12TR) may be used. The BG12TR is usually needed for semi-flush mounting with 4" (10.16 cm) or double-gang boxes (not with single-gang boxes).

Operation

Pushing in, then pulling down on the handle causes it to latch in the down/activated position. Once latched, the word "ACTIVATED" (in bright yellow) appears at the top of the handle, while a portion of the handle protrudes from the bottom of the station. To reset the station, simply unlock the station with the key and pull the door open. This action resets the handle; closing the door automatically resets the switch.

Each manual station, on command from the control panel, sends data to the panel representing the state of the manual switch. Two rotary decimal switches allow address settings (1 – 159 on FlashScan® systems, 1 – 99 on CLIP systems).

Architectural/Engineering Specifications

Manual Fire Alarm Stations shall be non-coded, with a key-operated reset lock in order that they may be tested, and so designed that after actual Emergency Operation, they cannot be restored to normal except by use of a key. An operated station shall automatically condition itself so as to be visually detected as activated. Manual stations shall be constructed of red-colored polycarbonate material with clearly visible operating instructions provided on the cover. The word FIRE shall appear on the front of the stations in white letters, 1.00 inches (2.54 cm) or larger. Stations shall be suitable for surface mounting on matching backbox SB-10 or SB-I/O; or semi-flush mounting on a standard single-gang, double-gang, or 4" (10.16 cm) square electrical box, and shall be installed within the limits defined by the Americans with Disabilities Act (ADA) or per national/local requirements. Manual Stations shall be Underwriters Laboratories listed.

Manual stations shall connect with two wires to one of the control panel SLC loops. The manual station shall, on command from the control panel, send data to the panel representing the

state of the manual switch. Manual stations shall provide address setting by use of rotary decimal switches.

The loop poll LED shall be clearly visible through the front of the station. The LED shall flash while in the normal condition, and stay steadily illuminated when in alarm.

Product Line Information

S464G1007: Dual-action addressable pull station. Includes key locking feature. (Listed for Canadian and non-Canadian applications.)

SB-10: Surface backbox; metal.

SB-IO: Surface backbox; plastic.

BG12TR: Optional trim ring.

17051: Keys, set of two.

NY-Plate: New York City trim plate.

NOTE: For S464 series conventional, non-addressable models including weatherproof S464F1008WP, see 85-3055.

Agency Listings and Approvals

In some cases, certain modules or applications may not be listed by certain approval agencies, or listing may be in process. Consult factory for latest listing status.

- **UL/ULC Listed:** S749 (listed for Canadian and non-Canadian applications).
- **MEA:** 67-02-E Vol. II.
- **CSFM:** 7150-1130:0209.
- **FDNY:** COA #6098, COA #6100.
- **FM Approved.**

Patented: U.S. Patent No. D428,351; 6,380,846; 6,314,772; 6,632,108.

This document is not intended to be used for installation purposes. We try to keep our product information up-to-date and accurate. We cannot cover all specific applications or anticipate all requirements. All specifications are subject to change without notice.

FlashScan® is a trademark and Eclipse™ is a registered trademark of Honeywell International Inc.

©2012 by Honeywell International Inc. All rights reserved. Unauthorized use of this document is strictly prohibited.

Automation and Control Solutions

Honeywell International Inc.
1985 Douglas Drive North
Golden Valley, MN 55422
www.honeywell.com

Honeywell Limited-Honeywell Limitée
35 Dynamic Drive
Scarborough, Ontario M1V 4Z9

74-3365-6 Rev. 04-12
April 2012
Made in the U.S.A.
© U.S. Registered Trademark
© 2012 Honeywell International Inc.
Page 2 of 2



74-3365-6

Honeywell