

PERMIT SET	03.28.18	
PERMIT SET	03.08.18	
1 ADDENDUM #1	12.05.17	
DESIGN DEVELOPMENT	08.25.17	
NO.	ISSUE	DATE
Job Number	B150311-000	
Drawn	DTM	
Checked	PJR	
Approved	PJR	

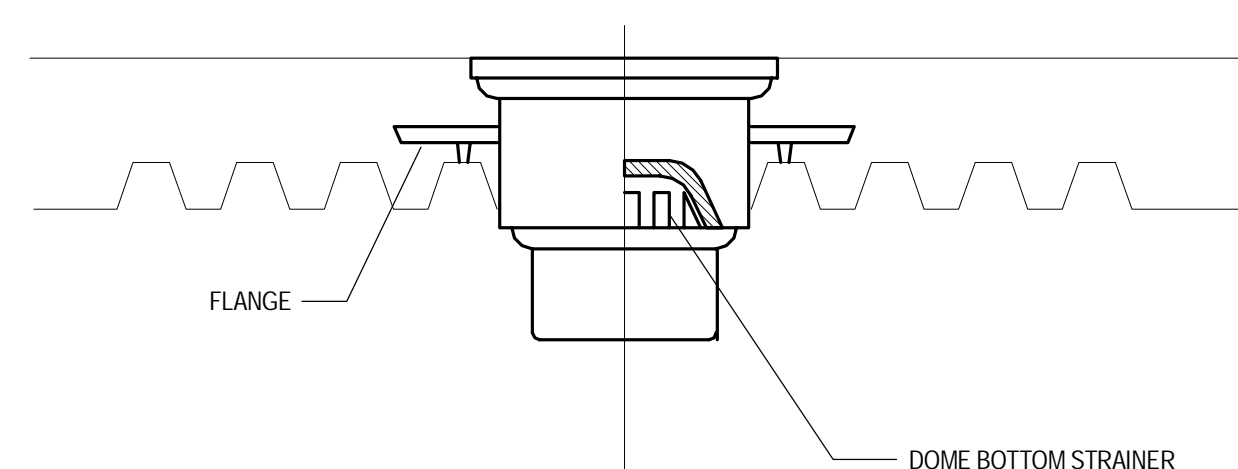

4 GARAGE DRAIN
SCALE: 1/8" = 1'-0"

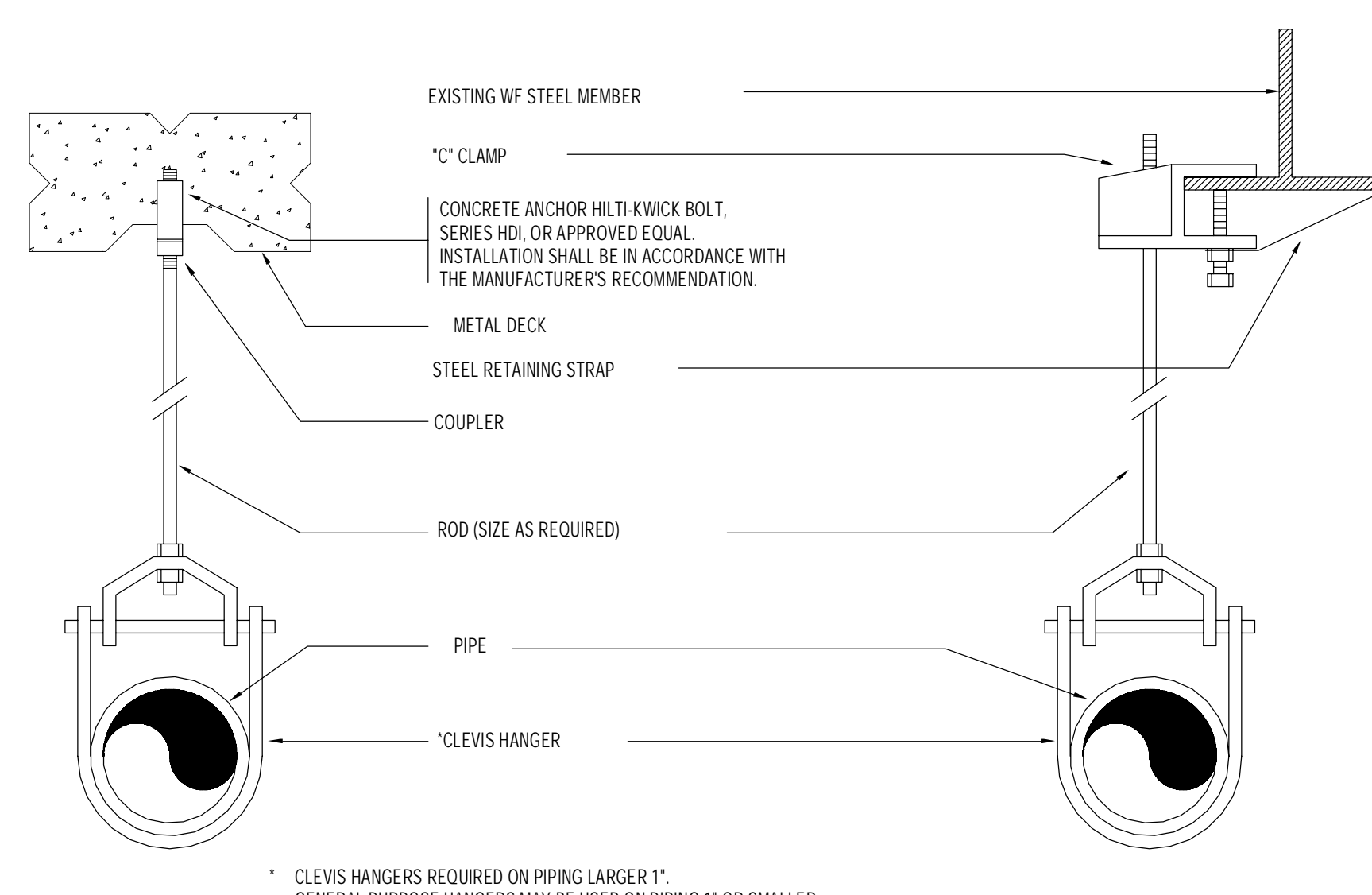

3 TYPICAL HANGER DETAIL
SCALE: 1/8" = 1'-0"

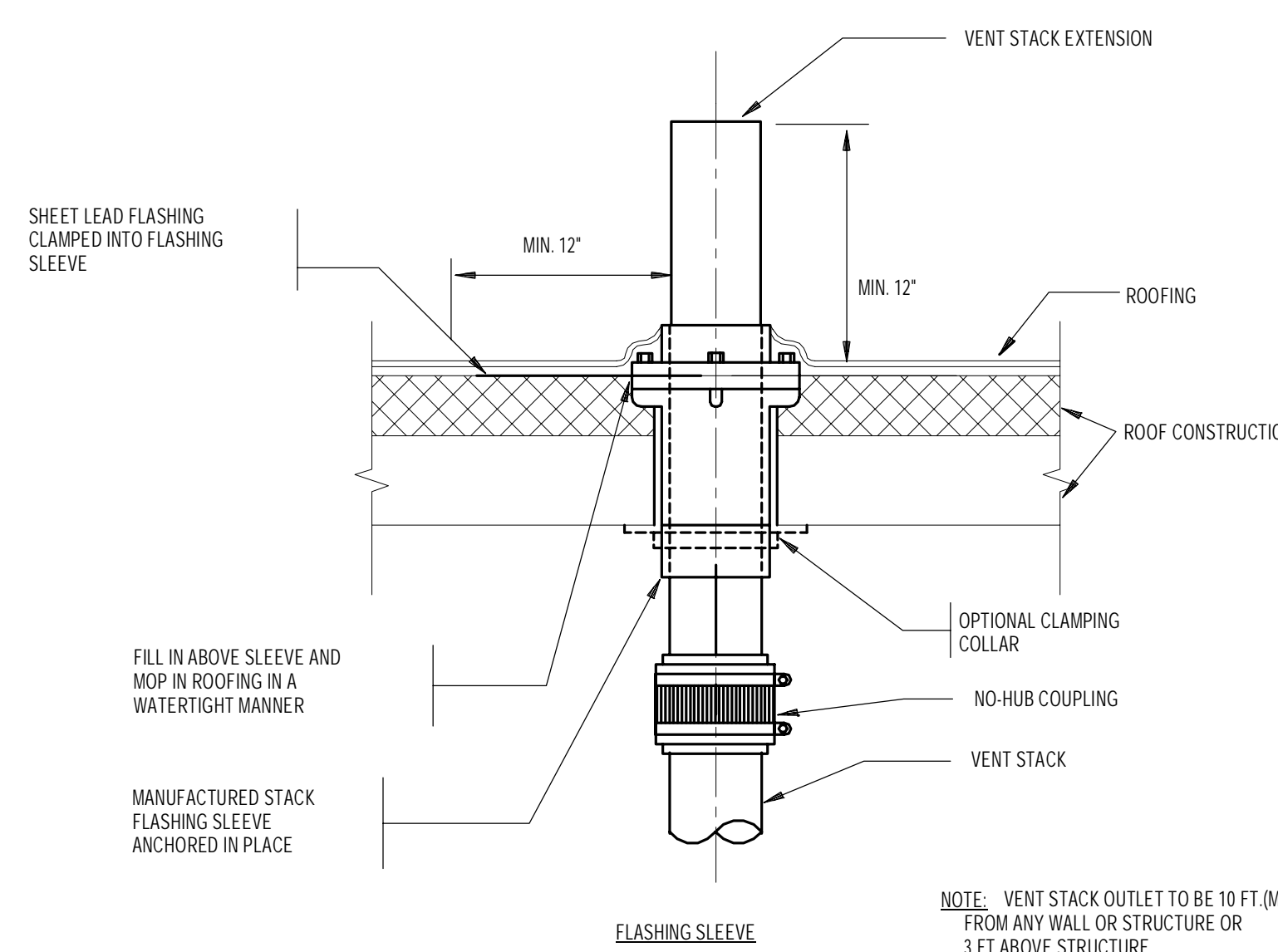

2 VENT THROUGH ROOF
SCALE: 1/8" = 1'-0"

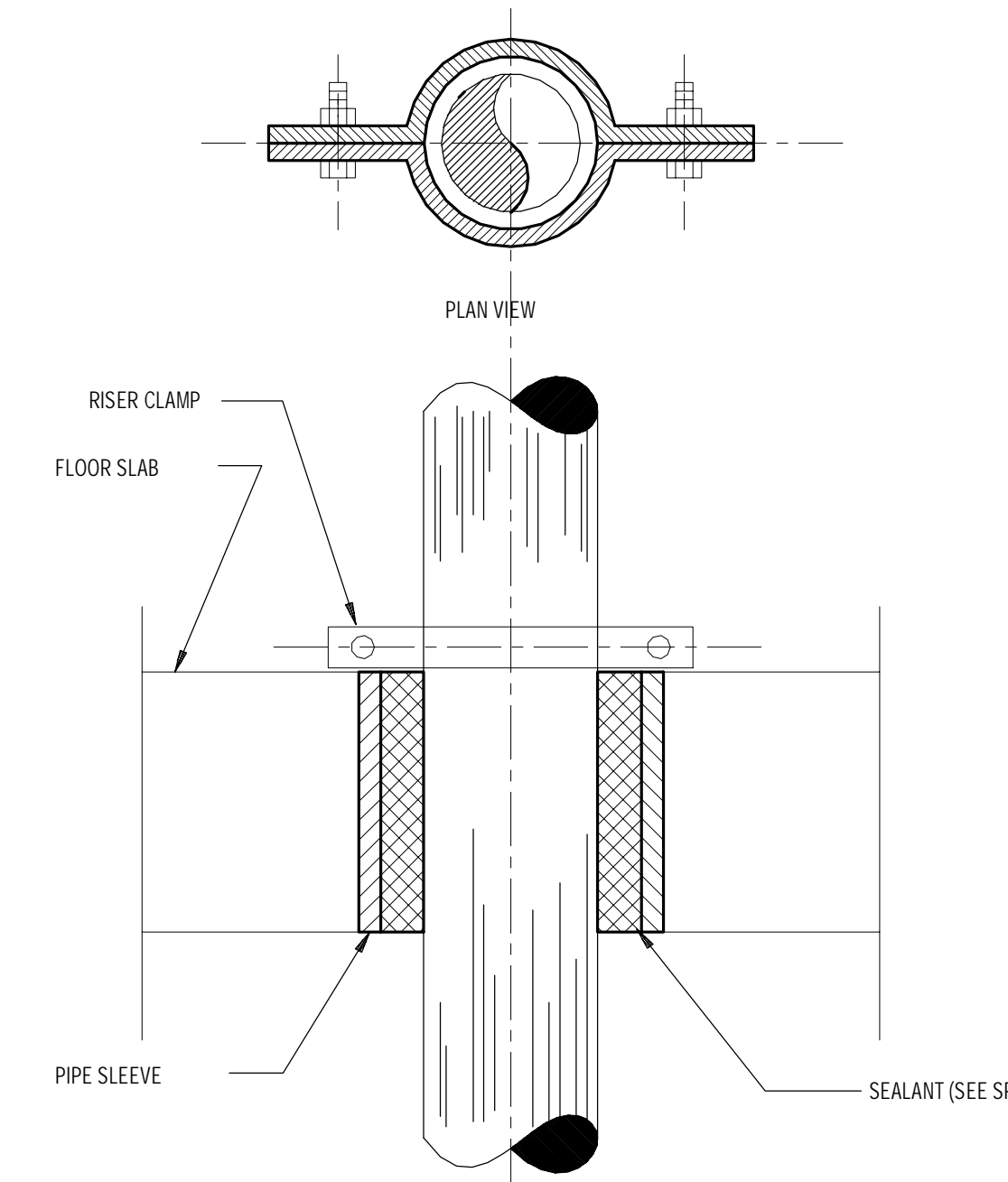

1 PIPE SLEEVE THROUGH FLOOR SLAB
SCALE: 1/8" = 1'-0"

DRAIN SCHEDULE								
LABEL	TYPE	BASE OF DESIGN		DRAIN BODY	STRAINER	STRAINER SIZE	OUTLET	REMARKS
		MFG.	MODEL #					
G01	GARAGE DRAIN	JAY R SMITH	2414 OBS	DUCO-CAST IRON	CAST IRON	1 1/2" DIAMETER	4"	WITH DOME BOTTOM STRAINER (PER DETAIL)

NOTES:

1. ALL FLOOR DRAINS IN FINISHED AREAS SHALL BE LOCATED AS PER THE ARCHITECTURAL DRAWINGS.
2. ALL FLOOR DRAINS IN MECHANICAL EQUIPMENT ROOMS, BOILER ROOMS, FAN ROOMS ETC SHALL BE LOCATED IN COORDINATION WITH THE MECHANICAL CONTRACTOR.
3. THE CONTRACTOR SHALL VERIFY THE COMPATIBILITY OF THE DRAINS WITH THE APPROVED OR WATER PROOFING SYSTEMS PRIOR TO SUBMITTING SHOP DRAWINGS.
4. THE TOP OF CURVE OF ALL FLOOR DRAINS SHALL BE FLUSH WITH THE ADJACENT FINISHED FLOOR.
5. REFER TO DRAWINGS.