

PERMIT SET	03.29.16	
PERMIT SET	03.09.16	
NO.	ISSUE	DATE
Job Number	152182.000	
Drawn	TEAM	
Checked	DS/RIS	
Approved	JK	

METAL RAILING & SPANDREL LEGEND
MATCH ALL ASPECTS OF METAL RAILINGS & PRECAST SPANDREL INCLUDING:
COLOR, SHEEN, FINISH, ATTACHMENT DETAILS, HARDWARE ETC.
FIELD VERIFY ANY DETAILS NOT LISTED AND DUPLICATE

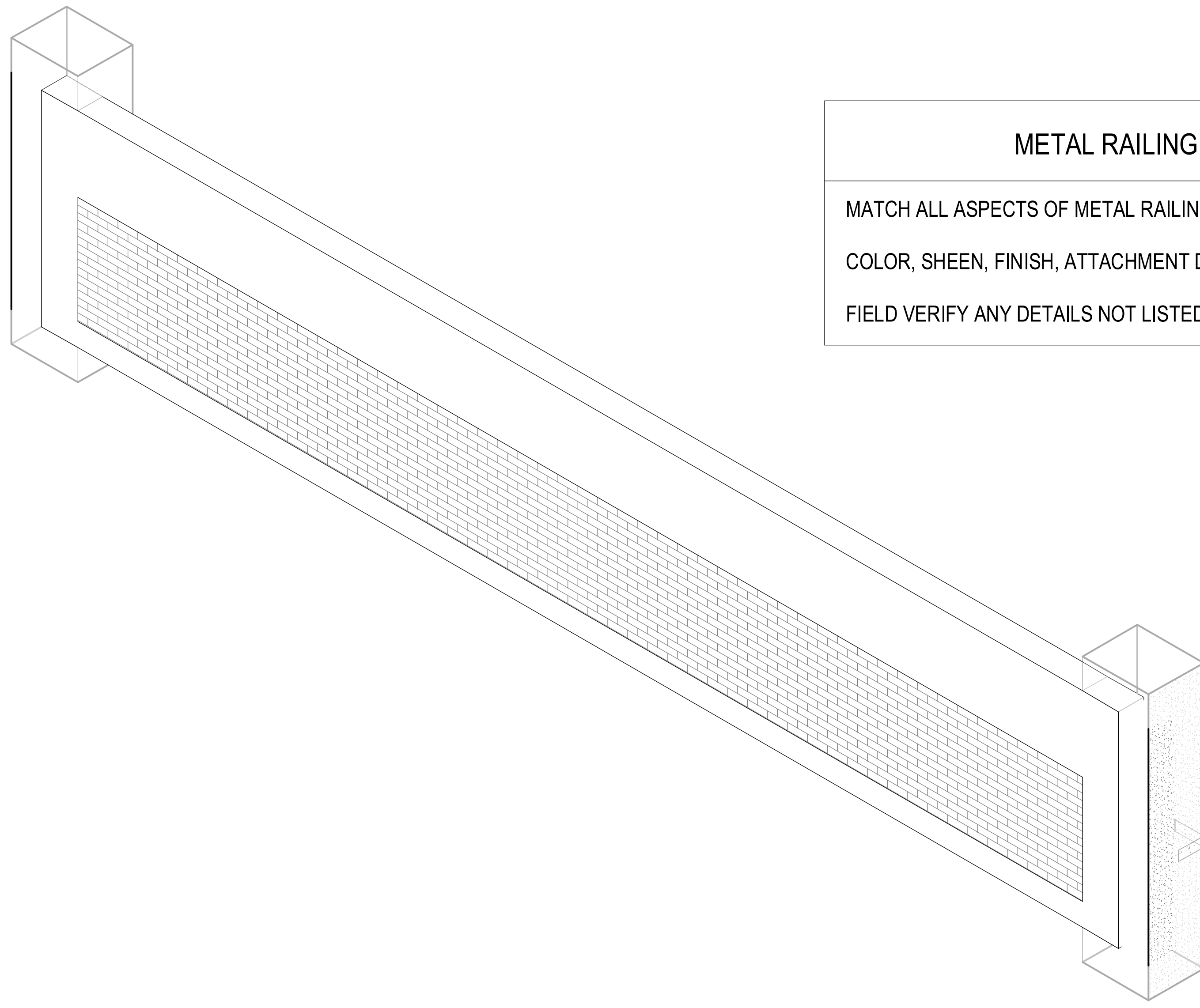

4 PRECAST SPANDREL (S1) EXTERIOR AXONOMETRIC

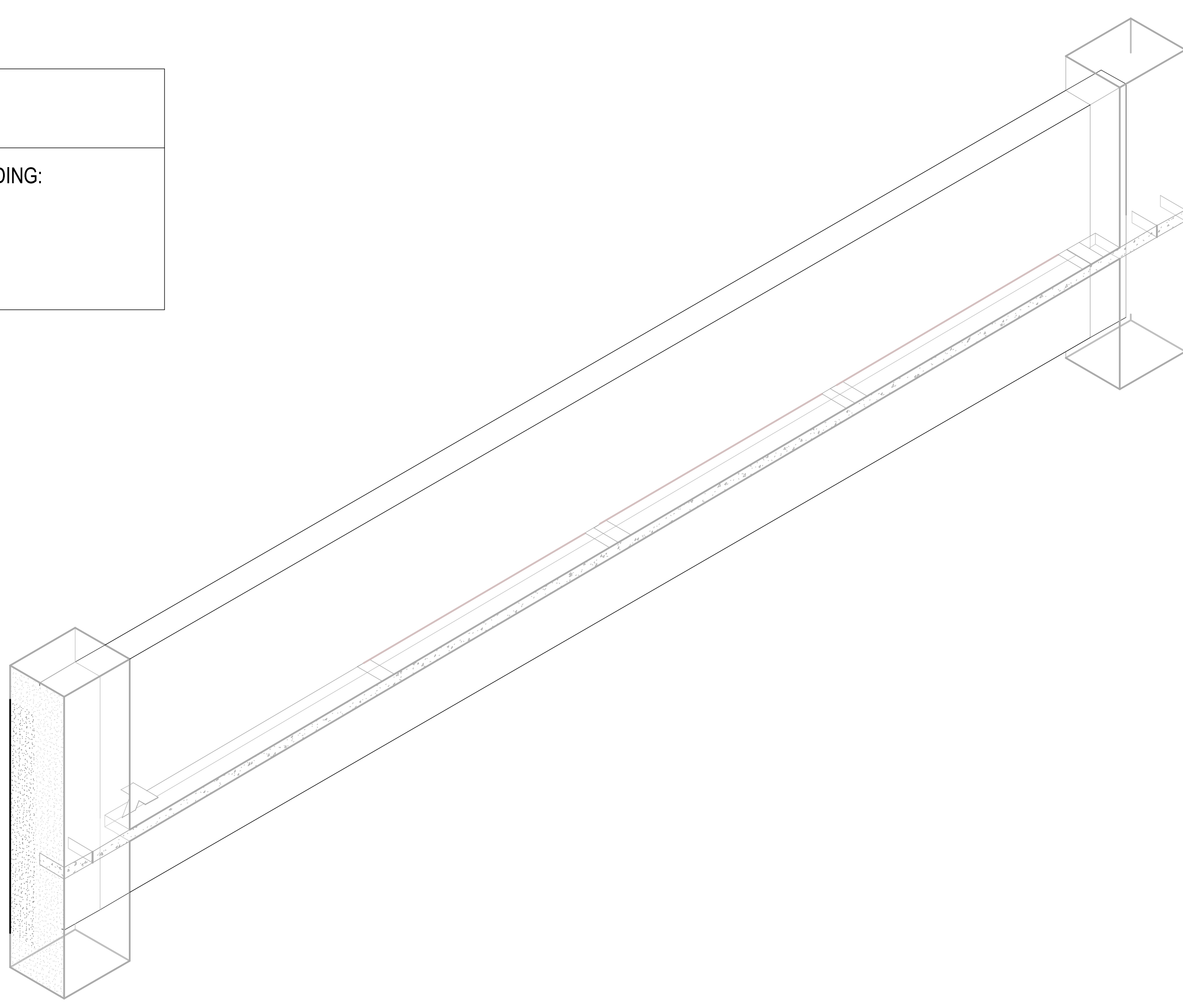

3 PRECAST SPANDREL (S1) INTERIOR AXONOMETRIC

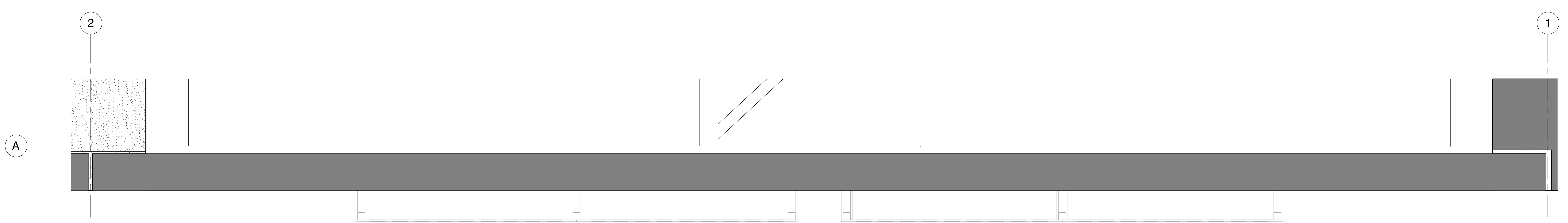

2 PRECAST SPANDREL (S1) PLAN
1" = 1'-0"

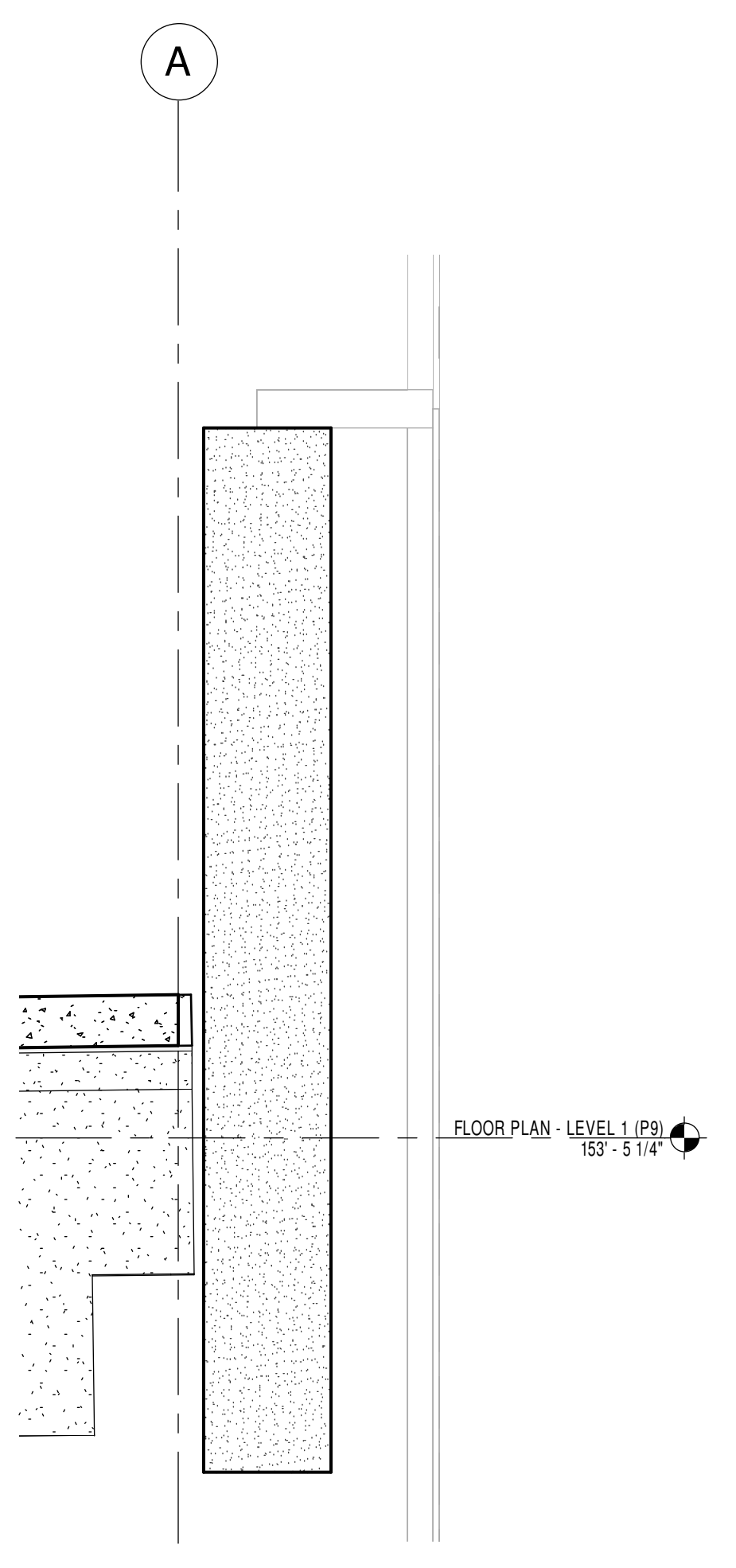

5 PRECAST SPANDREL (S1) SECTION
1" = 1'-0"

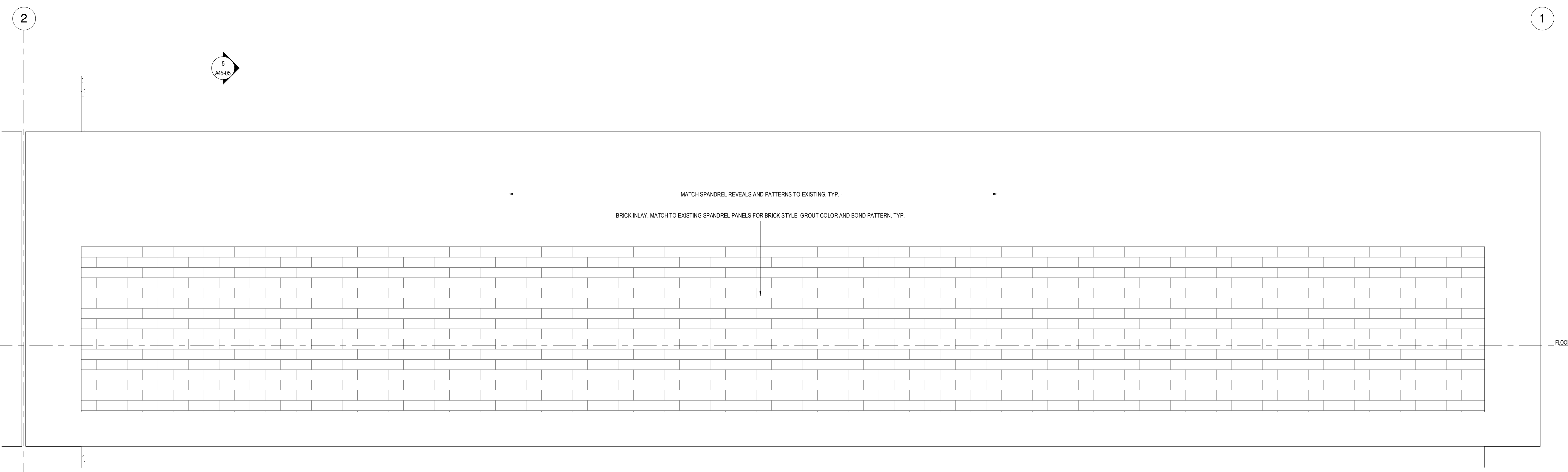

1 PRECAST SPANDREL (S1) ELEVATION
1" = 1'-0"